

## List of Revised Sections and Details

SECTION 01.00.00 – REFERENCES

SECTION 31.23.16 – EXCAVATION, TRENCHING AND BACKFILL

SECTION 32.12.16 – ASPHALTIC PAVING

SECTION 32.13.13 – CONCRETE PAVING

SECTION 33.11.13 – POTABLE WATER DISTRIBUTION

SECTION 33.11.15 – POTABLE WATER SERVICE

SECTION 33.31.13 – SANITARY SEWER MAIN

SECTION 33.31.15 – SANITARY SEWER SERVICE LINES

SECTION 33.41.13 – STORM SEWER PIPING

SECTION 33.49.13 – SANITARY SEWER MANHOLES

STANDARD DETAIL M01 – TRENCH – TYPICAL AND ALTERNATE

STANDARD DETAIL W02 – HYDRANT WITH GATE VALVE AND BOX

<b>SECTION 01.00.00 – REFERENCES</b> .....	<b>27</b>
GENERAL.....	<b>27</b>
<b>01.00.00.01 SUMMARY</b> .....	<b>27</b>
<b>01.00.00.02 LIST OF ORGANIZATIONS AND ASSOCIATIONS</b> .....	<b>27</b>
<b>SECTION 01.31.13 – PROJECT MANAGEMENT AND COORDINATION</b> .....	<b>29</b>
<b>GENERAL</b> .....	<b>29</b>
01.31.13.01 SUMMARY .....	29
01.31.13.02 PRE-CONSTRUCTION CONFERENCE .....	29
01.31.13.03 CONSTRUCTION SCHEDULE.....	29
01.31.13.04 WORKING HOURS/DAYS .....	29
01.31.13.05 COORDINATION WITH OTHER CONTRACTORS/UTILITIES.....	29
<b>SECTION 01.31.15 – SUBMITTAL PROCEDURES</b> .....	<b>31</b>
<b>GENERAL</b> .....	<b>31</b>
01.31.15.01 SUMMARY .....	31
01.31.15.02 SUBMITTAL PROCEDURES .....	31
<b>SECTION 01.45.23 – QUALITY REQUIREMENTS</b> .....	<b>32</b>
<b>GENERAL</b> .....	<b>32</b>
01.45.23.01 SUMMARY .....	32
01.45.23.02 SUBMITTALS.....	32
01.45.23.03 INSTALLER QUALIFICATIONS .....	32
01.45.23.04 CONTROL OF INSTALLATION .....	32
01.45.23.05 MANUFACTURER’S FIELD SERVICES .....	32
01.45.23.06 WARRANTY.....	32
<b>SECTION 01.71.23 – STAKING AND CONSTRUCTION SURVEYING</b> .....	<b>33</b>
<b>GENERAL</b> .....	<b>33</b>
01.71.23.01 SUMMARY .....	33
01.71.23.02 RELATED WORK.....	33
01.71.23.03 STAKING PROVIDED TO THE CONTRACTOR .....	33
01.71.23.04 CONTRACTOR’S RESPONSIBILITY.....	33
<b>SECTION 01.74.13 – CLOSEOUT PROCEDURES</b> .....	<b>35</b>
<b>GENERAL</b> .....	<b>35</b>
01.74.13.01 SUMMARY .....	35
01.74.13.02 CLOSEOUT PROCEDURES.....	35

01.74.13.03	FINAL CLEANING.....	35
01.74.13.04	FINAL INSPECTION.....	35
01.74.13.05	PUNCH LIST .....	35
<b>SECTION 03.05.13 – CONCRETE.....</b>		<b>36</b>
<b>GENERAL .....</b>		<b>36</b>
03.05.13.01	SUMMARY .....	36
03.05.13.02	RELATED WORK.....	36
03.05.13.03	REFERENCES .....	36
03.05.13.04	SUBMITTALS.....	37
03.05.13.05	QUALITY ASSURANCE .....	38
03.05.13.06	FIELD QUALITY CONTROL .....	38
<b>PRODUCTS.....</b>		<b>38</b>
03.05.13.07	REINFORCEMENT .....	38
03.05.13.08	CONCRETE MATERIALS.....	39
03.05.13.09	ACCESSORIES.....	40
<b>EXECUTION.....</b>		<b>40</b>
03.05.13.10	PLACEMENT OF REINFORCEMENT .....	40
03.05.13.11	PLACING CONCRETE .....	41
03.05.13.12	CONCRETE FINISHING OF UNFORMED SURFACES .....	42
03.05.13.13	CONCRETE FINISHING OF FORMED SURFACES .....	42
03.05.13.14	CONCRETE FINISHING OF FLOORS .....	43
03.05.13.15	EMBEDDED ITEMS.....	43
03.05.13.17	ADMIXTURES .....	43
03.05.13.18	CURING.....	43
03.05.13.19	CONCRETE ACCESSORIES.....	44
03.05.13.20	DEFECTIVE CONCRETE.....	45
<b>PRICE AND PAYMENT.....</b>		<b>45</b>
03.05.13.21	METHOD OF MEASUREMENT .....	45
03.05.13.22	BASIS OF PAYMENT .....	46
<b>SECTION 03.05.15 – LOW-DENSITY CELLULAR CONCRETE.....</b>		<b>47</b>
<b>GENERAL .....</b>		<b>47</b>
03.05.15.01	SUMMARY .....	47
03.05.15.02	RELATED WORK.....	47

03.05.15.03	REFERENCES .....	47
03.05.15.04	SUBMITTALS .....	47
03.05.15.05	QUALITY ASSURANCE .....	48
03.05.15.06	FIELD QUALITY CONTROL .....	48
03.05.15.07	EQUIPMENT.....	48
<b>PRODUCTS.....</b>		<b>48</b>
03.05.15.08	FOAM CONCENTRATE .....	48
03.05.15.09	CEMENT.....	49
03.05.15.10	WATER.....	49
03.05.15.11	ADMIXTURES.....	49
03.05.15.12	MIX DESIGN .....	49
<b>EXECUTION .....</b>		<b>49</b>
03.05.15.13	SPECIALIZED BATCHING, MIXING, AND PLACING EQUIPMENT.....	49
03.05.15.14	PERSONNEL REQUIREMENTS .....	50
03.05.15.15	QUALITY CONTROL AND QUALITY ASSURANCE TESTING .....	50
03.05.15.16	MIXING AND PLACEMENT .....	50
03.05.15.17	ACCEPTANCE .....	51
03.05.15.18	DEFECTIVE CONCRETE.....	51
<b>PRICE AND PAYMENT .....</b>		<b>52</b>
03.05.15.19	METHOD OF MEASUREMENT .....	52
03.05.15.20	BASIS OF PAYMENT .....	52
<b>SECTION 03.11.13 – CONCRETE FORMWORK.....</b>		<b>53</b>
<b>GENERAL .....</b>		<b>53</b>
03.11.13.01	SUMMARY .....	53
03.11.13.02	RELATED WORK.....	53
03.11.13.03	REFERENCES .....	53
03.11.13.04	SUBMITTALS .....	53
03.11.13.05	QUALITY ASSURANCE .....	53
<b>PRODUCTS.....</b>		<b>53</b>
03.11.13.06	FORM SURFACES .....	53
03.11.13.07	FORM COATING.....	54
03.11.13.08	FORM TIES .....	54
<b>EXECUTION .....</b>		<b>54</b>

03.11.13.09	PREPARATION .....	54
03.11.13.10	FIELD QUALITY CONTROL .....	54
03.11.13.11	INSTALLATION OF FORMS .....	55
03.11.13.12	REMOVAL OF FORMS .....	55
03.11.13.13	RESHORING .....	56
<b>SECTION 31.11.10</b>	<b>– SITE CLEARING.....</b>	<b>57</b>
<b>GENERAL</b>	<b>.....</b>	<b>57</b>
31.11.10.01	SUMMARY .....	57
31.11.10.02	RELATED WORK.....	57
<b>EXECUTION</b>	<b>.....</b>	<b>57</b>
31.11.10.03	CLEARING AND GRUBBING.....	57
<b>PRICE AND PAYMENT</b>	<b>.....</b>	<b>58</b>
31.11.10.04	METHOD OF MEASUREMENT .....	58
31.11.10.05	BASIS OF PAYMENT .....	58
<b>SECTION 31.14.13</b>	<b>– EARTHWORK.....</b>	<b>59</b>
<b>GENERAL</b>	<b>.....</b>	<b>59</b>
31.14.13.01	SUMMARY .....	59
31.14.13.02	RELATED WORK.....	59
<b>EXECUTION</b>	<b>.....</b>	<b>59</b>
31.14.13.03	ROUGH GRADING.....	59
31.14.13.04	FINISH GRADING .....	59
<b>PRICE AND PAYMENT</b>	<b>.....</b>	<b>59</b>
31.14.13.05	METHOD OF MEASUREMENT .....	59
31.14.13.06	BASIS OF PAYMENT .....	60
<b>SECTION 31.23.16</b>	<b>– EXCAVATION, TRENCHING AND BACKFILL .....</b>	<b>61</b>
<b>GENERAL</b>	<b>.....</b>	<b>61</b>
31.23.16.01	SUMMARY .....	61
31.23.16.02	RELATED WORK.....	61
31.23.16.03	REFERENCES .....	61
31.23.16.04	SUBMITTALS.....	62
31.23.16.05	DEFINITIONS.....	62
<b>PRODUCTS</b>	<b>.....</b>	<b>64</b>
31.23.16.06	BEDDING, HAUNCHING AND INITIAL BACKFILL MATERIAL.....	64

31.23.16.07	INSULATION.....	64
<b>EXECUTION.....</b>		<b>64</b>
31.23.16.08	GENERAL.....	64
31.23.16.09	EXCAVATION .....	65
31.23.16.10	TRENCHING .....	65
31.23.16.11	BEDDING.....	65
31.23.16.12	HAUNCHING AND INITIAL BACKFILL.....	67
31.23.16.13	FINAL BACKFILL.....	68
31.23.16.14	FROST PROTECTION .....	69
31.23.16.15	REMOVAL OF NUISANCE WATER .....	69
31.23.16.16	LOCATE EXISTING UTILITIES .....	69
31.23.16.17	UTILITY CONFLICTS.....	70
31.23.16.18	MOVING FENCES AND MINOR STRUCTURES .....	71
31.23.16.19	RECORDS .....	71
<b>PRICE AND PAYMENT.....</b>		<b>71</b>
31.23.16.20	METHOD OF MEASUREMENT .....	71
31.23.16.21	BASIS OF PAYMENT .....	71
<b>SECTION 31.23.17 – ROCK EXCAVATION.....</b>		<b>72</b>
<b>GENERAL .....</b>		<b>72</b>
31.23.17.01	SUMMARY .....	72
31.23.17.02	RELATED WORK.....	72
31.23.17.03	REFERENCES .....	72
31.23.17.04	SUBMITTALS .....	72
31.23.17.05	DEFINITIONS.....	72
31.23.17.06	QUALITY ASSURANCE .....	72
<b>PRODUCTS.....</b>		<b>73</b>
31.23.17.07	BEDDING MATERIAL.....	73
<b>EXECUTION.....</b>		<b>73</b>
31.23.17.08	ROCK MEASUREMENT.....	73
31.23.17.09	EXCAVATION .....	73
31.23.17.10	BLASTING.....	73
31.23.17.11	BACKFILLING.....	74
31.23.17.12	AS-BUILTS .....	74

<b>PRICE AND PAYMENT .....</b>	<b>74</b>
31.23.17.13    GENERAL.....	74
31.23.17.14    EXCAVATED ROCK .....	74
<b>SECTION 31.23.19 – DEWATERING .....</b>	<b>75</b>
<b>GENERAL .....</b>	<b>75</b>
31.23.19.01    SUMMARY .....	75
31.23.19.02    RELATED WORK.....	75
31.23.19.03    SUBMITTALS.....	75
31.23.19.04    QUALITY ASSURANCE .....	75
<b>EXECUTION .....</b>	<b>75</b>
31.23.19.05    PREPARATION .....	75
31.23.19.06    PERFORMANCE .....	76
<b>PRICE AND PAYMENT .....</b>	<b>76</b>
31.23.19.07    DEWATERING 1 .....	76
31.23.19.08    DEWATERING 2 .....	76
<b>SECTION 32.01.13 – STREET CRACK SEALING .....</b>	<b>77</b>
<b>GENERAL .....</b>	<b>77</b>
32.01.13.01    SUMMARY .....	77
32.01.13.02    RELATED WORK.....	77
32.01.13.03    REFERENCES .....	77
32.01.13.04    SUBMITTALS.....	77
32.01.13.05    QUALITY ASSURANCE .....	77
<b>PRODUCTS.....</b>	<b>77</b>
32.01.13.06    PRODUCTS.....	77
<b>EXECUTION .....</b>	<b>78</b>
32.01.13.07    GENERAL.....	78
32.01.13.08    ROUTING .....	78
32.01.13.09    CLEANING .....	78
32.01.13.10    SEALING.....	78
32.01.13.11    SEASONAL AND TEMPERATURE LIMITATIONS.....	79
<b>PRICE AND PAYMENT .....</b>	<b>79</b>
32.01.13.12    METHOD OF MEASUREMENT .....	79
32.01.13.13    BASIS OF PAYMENT .....	80

<b>SECTION 32.01.14 – ASPHALT STREET CHIP SEALING .....</b>	<b>81</b>
<b>GENERAL .....</b>	<b>81</b>
32.01.14.01    SUMMARY .....	81
32.01.14.02    RELATED WORK.....	81
32.01.14.03    REFERENCES .....	81
32.01.14.04    SUBMITTALS .....	81
32.01.14.05    QUALITY ASSURANCE .....	81
<b>PRODUCTS.....</b>	<b>82</b>
32.01.14.06    PRODUCTS.....	82
<b>EXECUTION.....</b>	<b>82</b>
32.01.14.07    GENERAL.....	82
32.01.14.08    ASPHALT SURFACE TREATMENT .....	82
32.01.14.09    SEAL COAT .....	82
32.01.14.10    TRAFFIC CONTROL.....	83
<b>PRICE AND PAYMENT.....</b>	<b>83</b>
32.01.14.11    METHOD OF MEASUREMENT .....	83
32.01.14.12    BASIS OF PAYMENT .....	84
<b>SECTION 32.06.10 – CONCRETE SIDEWALK, HANDICAP RAMPS, AND/OR DETECTABLE/TACTILE WARNING SURFACES .....</b>	<b>85</b>
<b>GENERAL .....</b>	<b>85</b>
32.06.10.01    SUMMARY .....	85
32.06.10.02    RELATED WORK.....	85
32.06.10.03    SUBMITTALS .....	85
<b>PRODUCTS.....</b>	<b>85</b>
32.06.10.04    CUSHION MATERIAL.....	85
32.06.10.05    CONCRETE .....	85
32.06.10.06    DETECTABLE / TACTILE WARNING SURFACES.....	86
<b>EXECUTION.....</b>	<b>86</b>
32.06.10.07    FOUNDATION .....	86
32.06.10.08    FORMS.....	86
32.06.10.09    JOINTS .....	86
32.06.10.10    FINISHING .....	87
32.06.10.11    COMPLETION.....	87



32.06.10.12	TESTING .....	87
32.06.10.13	DETECTABLE/TACTILE WARNING SURFACE .....	87
<b>PRICE AND PAYMENT .....</b>		<b>87</b>
32.06.10.14	METHOD OF MEASUREMENT .....	87
32.06.10.15	BASIS OF PAYMENT .....	88
<b>SECTION 32.11.23 – GRAVEL (RE)SURFACING .....</b>		<b>89</b>
<b>GENERAL .....</b>		<b>89</b>
32.11.23.01	SUMMARY .....	89
32.11.23.02	REFERENCES .....	89
32.11.23.03	SUBMITTALS .....	89
<b>PRODUCTS .....</b>		<b>90</b>
32.11.23.04	SUBBASE, BASE, GRAVEL CUSHION, AND GRAVEL SURFACING .....	90
32.11.23.05	CLAY BINDER .....	90
32.11.23.06	SALVAGED SUBBASE, BASE, GRAVEL CUSHION, AND GRAVEL SURFACING .....	90
32.11.23.07	DUST CONTROL PRODUCT .....	90
<b>EXECUTION .....</b>		<b>90</b>
32.11.23.08	INSTALLATION .....	90
<b>PRICE AND PAYMENT .....</b>		<b>91</b>
32.11.23.09	METHOD OF MEASUREMENT .....	91
32.11.23.10	BASIS OF PAYMENT .....	92
<b>SECTION 32.12.10 – PRIME, TACK, AND SEAL COATS .....</b>		<b>93</b>
<b>GENERAL .....</b>		<b>93</b>
32.12.10.01	SUMMARY .....	93
32.12.10.02	RELATED WORK .....	93
32.12.10.03	REFERENCES .....	93
32.12.10.04	SUBMITTALS .....	93
32.12.10.05	QUALITY ASSURANCE .....	94
<b>PRODUCTS .....</b>		<b>95</b>
32.12.10.06	MATERIALS .....	95
32.12.10.07	EQUIPMENT .....	95
<b>EXECUTION .....</b>		<b>95</b>
32.12.10.08	SURFACE PREPARATION .....	95
32.12.10.09	MATERIAL APPLICATION .....	95

32.12.10.10	TRAFFIC CONTROL.....	95
<b>PRICE AND PAYMENT .....</b>		<b>96</b>
32.12.10.11	METHOD OF MEASUREMENT .....	96
32.12.10.12	BASIS OF PAYMENT .....	96
<b>SECTION 32.12.16 – ASPHALTIC PAVING .....</b>		<b>97</b>
<b>GENERAL .....</b>		<b>97</b>
32.12.16.01	SUMMARY .....	97
32.12.16.02	RELATED WORK.....	97
32.12.16.03	REFERENCES .....	97
32.12.16.04	SUBMITTALS .....	98
32.12.16.05	QUALITY ASSURANCE .....	98
<b>PRODUCTS.....</b>		<b>103</b>
32.12.16.06	AGGREGATE SUBBASE.....	103
32.12.16.07	AGGREGATE BASE COURSE .....	103
32.12.16.08	HOT MIX ASPHALT .....	103
32.12.16.09	EQUIPMENT.....	103
<b>EXECUTION .....</b>		<b>104</b>
32.12.16.10	ASPHALT REMOVAL.....	104
32.12.16.11	GRANULAR BASES .....	104
32.12.16.12	ASPHALT PLACEMENT .....	104
32.12.16.13	TESTING .....	107
32.12.16.14	ASPHALT PATCHING .....	108
32.12.16.15	COLD-MIX ASPHALT.....	110
32.12.16.16	TRAFFIC CONTROL.....	111
<b>PRICE AND PAYMENT .....</b>		<b>111</b>
32.12.16.17	METHOD OF MEASUREMENT .....	111
32.12.16.18	BASIS OF PAYMENT .....	112
<b>SECTION 32.13.13 – CONCRETE PAVING.....</b>		<b>113</b>
<b>GENERAL .....</b>		<b>113</b>
32.13.13.01	SUMMARY .....	113
32.13.13.02	RELATED WORK.....	113
32.13.13.03	REFERENCES .....	113
32.13.13.04	SUBMITTALS .....	113

32.13.13.05	QUALITY ASSURANCE .....	114
<b>PRODUCTS.....</b>		<b>118</b>
32.13.13.06	AGGREGATE SUBBASE .....	118
32.13.13.07	AGGREGATE BASE COURSE .....	118
32.13.13.08	PORTLAND CEMENT CONCRETE.....	118
32.13.13.09	CONCRETE CURING MATERIALS.....	118
32.13.13.10	PREFORMED EXPANSION JOINT FILLER FOR CONCRETE.....	118
32.13.13.11	CONCRETE JOINT SEALER .....	118
32.13.13.12	STEEL DOWEL BARS.....	119
32.13.13.13	DOWEL BAR EPOXY RESIN .....	119
<b>EXECUTION .....</b>		<b>119</b>
32.13.13.14	INSTALLATION .....	119
<b>PRICE AND PAYMENT .....</b>		<b>120</b>
32.13.13.15	METHOD OF MEASUREMENT .....	120
32.13.13.16	BASIS OF PAYMENT .....	121
<b>SECTION 32.16.13 – CONCRETE CURB AND GUTTER.....</b>		<b>123</b>
<b>GENERAL .....</b>		<b>123</b>
32.16.13.01	SUMMARY .....	123
32.16.13.02	RELATED WORK.....	123
32.16.13.03	SUBMITTALS .....	123
<b>PRODUCTS.....</b>		<b>123</b>
32.16.13.04	CONCRETE PRODUCTS.....	123
<b>EXECUTION .....</b>		<b>123</b>
32.16.13.05	GENERAL.....	123
32.16.13.06	FOUNDATION .....	124
32.16.13.07	FORMS.....	124
32.16.13.08	FINISHING .....	124
32.16.13.09	JOINTS .....	124
32.16.13.10	COMPLETION.....	125
32.16.13.11	TESTING .....	125
<b>PRICE AND PAYMENT .....</b>		<b>125</b>
32.16.13.12	METHOD OF MEASUREMENT .....	125
32.16.13.13	BASIS OF PAYMENT .....	125

<b>SECTION 32.16.15 – DRAINAGE PAN AND FILLET .....</b>	<b>127</b>
<b>GENERAL .....</b>	<b>127</b>
32.16.15.01    SUMMARY .....	127
32.16.15.02    RELATED WORK.....	127
32.16.15.03    REFERENCES .....	127
32.16.15.04    SUBMITTALS .....	127
32.16.15.05    QUALITY ASSURANCE .....	127
<b>PRODUCTS.....</b>	<b>128</b>
32.16.15.06    AGGREGATE SUBBASE.....	128
32.16.15.07    AGGREGATE BASE COURSE .....	128
32.16.15.08    ASPHALT CONCRETE.....	128
32.16.15.09    PORTLAND CEMENT CONCRETE.....	128
<b>EXECUTION .....</b>	<b>128</b>
32.16.15.10    GENERAL.....	128
32.16.15.11    ROADWAY SURFACE REMOVAL .....	129
32.16.15.12    ASPHALT AND CONCRETE PLACEMENT.....	129
32.16.15.13    MANHOLE AND VALVE BOX ADJUSTMENTS .....	129
<b>PRICE AND PAYMENT .....</b>	<b>130</b>
32.16.15.14    METHOD OF MEASUREMENT .....	130
32.16.15.15    BASIS OF PAYMENT .....	130
<b>SECTION 32.17.23 – PAVEMENT MARKING.....</b>	<b>131</b>
<b>GENERAL .....</b>	<b>131</b>
32.17.23.01    SUMMARY .....	131
32.17.23.02    RELATED WORK.....	131
32.17.23.03    REFERENCES .....	131
32.17.23.04    SUBMITTALS .....	131
32.17.23.05    QUALITY ASSURANCE .....	131
<b>PRODUCTS.....</b>	<b>131</b>
32.17.23.06    TRAFFIC CONTROL DEVICES .....	131
32.17.23.07    PAVEMENT MARKING TAPE .....	131
32.17.23.08    PAINT.....	132
<b>EXECUTION .....</b>	<b>132</b>
32.17.23.09    GENERAL.....	132

32.17.23.10	PAVEMENT MARKING .....	132
32.17.23.11	REMOVAL OF PAVEMENT MARKINGS.....	133
<b>PRICE AND PAYMENT .....</b>		<b>134</b>
32.17.23.12	METHOD OF MEASUREMENT .....	134
32.17.23.13	BASIS OF PAYMENT .....	134
<b>SECTION 32.91.19 – TOPSOILING .....</b>		<b>135</b>
<b>GENERAL .....</b>		<b>135</b>
32.91.19.01	SUMMARY .....	135
32.91.19.02	RELATED WORK.....	135
32.91.19.03	REFERENCES .....	135
32.91.19.04	SUBMITTALS.....	135
32.91.19.05	QUALITY ASSURANCE .....	135
<b>PRODUCTS.....</b>		<b>136</b>
32.91.19.06	TOPSOIL.....	136
<b>EXECUTION .....</b>		<b>136</b>
32.91.19.07	GENERAL.....	136
32.91.19.08	TOPSOILING.....	136
<b>PRICE AND PAYMENT .....</b>		<b>136</b>
32.91.19.09	METHOD OF MEASUREMENT .....	136
32.91.19.10	BASIS OF PAYMENT .....	136
<b>SECTION 32.91.21 – FERTILIZING.....</b>		<b>137</b>
<b>GENERAL .....</b>		<b>137</b>
32.91.21.01	SUMMARY .....	137
32.91.21.02	RELATED WORK.....	137
32.91.21.03	REFERENCES .....	137
32.91.21.04	SUBMITTALS.....	137
32.91.21.05	QUALITY ASSURANCE .....	137
<b>PRODUCTS.....</b>		<b>138</b>
32.91.21.06	FERTILIZER .....	138
<b>EXECUTION .....</b>		<b>138</b>
32.91.21.07	GENERAL.....	138
32.91.21.08	FERTILIZING .....	138
<b>PRICE AND PAYMENT .....</b>		<b>139</b>

32.91.21.09	METHOD OF MEASUREMENT .....	139
32.91.21.10	BASIS OF PAYMENT .....	139
<b>SECTION 32.92.19 – SEEDING.....</b>		<b>140</b>
<b>GENERAL .....</b>		<b>140</b>
32.92.19.01	SUMMARY .....	140
32.92.19.02	RELATED WORK.....	140
32.92.19.03	REFERENCES .....	140
32.92.19.04	SUBMITTALS .....	140
32.92.19.05	QUALITY ASSURANCE .....	140
<b>PRODUCTS.....</b>		<b>141</b>
32.92.19.06	SEED .....	141
<b>EXECUTION .....</b>		<b>142</b>
32.92.19.07	GENERAL.....	142
32.92.19.08	SEEDING .....	142
32.92.19.09	DRILLING.....	143
32.92.19.10	HYDROSEEDING.....	144
32.92.19.11	COMPLETION REQUIREMENTS.....	144
<b>PRICE AND PAYMENT .....</b>		<b>145</b>
32.92.19.12	METHOD OF MEASUREMENT .....	145
32.92.19.13	BASIS OF PAYMENT .....	145
<b>SECTION 32.92.21 – MULCHING.....</b>		<b>147</b>
<b>GENERAL .....</b>		<b>147</b>
32.92.21.01	SUMMARY .....	147
32.92.21.02	RELATED WORK.....	147
32.92.21.03	REFERENCES .....	147
32.92.21.04	SUBMITTALS .....	147
32.92.21.05	QUALITY ASSURANCE .....	147
<b>PRODUCTS.....</b>		<b>147</b>
32.92.21.06	GENERAL.....	147
<b>EXECUTION .....</b>		<b>149</b>
32.92.21.07	GENERAL.....	149
32.92.21.08	MULCHING .....	149
<b>PRICE AND PAYMENT .....</b>		<b>150</b>

32.92.21.09	METHOD OF MEASUREMENT .....	150
32.92.21.10	BASIS OF PAYMENT .....	150
<b>SECTION 33.05.23 – BORING, JACKING, AND DIRECTIONAL DRILLING.....</b>		<b>152</b>
<b>GENERAL .....</b>		<b>152</b>
33.05.23.01	SUMMARY .....	152
33.05.23.02	RELATED WORK.....	152
33.05.23.03	REFERENCES .....	152
33.05.23.04	SUBMITTALS .....	152
33.05.23.05	QUALITY ASSURANCE .....	152
<b>PRODUCTS.....</b>		<b>153</b>
33.05.23.06	PVC CASING .....	153
33.05.23.07	YELOMINE CASING .....	153
33.05.23.08	HIGH DENSITY POLYETHYLENE CASING (HDPE) .....	153
33.05.23.09	STEEL PIPE CASING .....	153
33.05.23.10	CASING SPACERS .....	153
33.05.23.11	PIPE END SEALS .....	153
<b>EXECUTION .....</b>		<b>154</b>
33.05.23.12	GENERAL.....	154
33.05.23.13	BORING AND JACKING.....	154
33.05.23.14	DIRECTIONAL DRILLING.....	155
33.05.23.15	NON-CASED DIRECTIONAL DRILLING .....	156
<b>PRICE AND PAYMENT.....</b>		<b>156</b>
33.05.23.16	BORING AND JACKING.....	156
33.05.23.17	DIRECTIONAL DRILLING.....	156
33.05.23.18	NON-CASED DIRECTIONAL DRILLING .....	157
<b>SECTION 33.05.25 – STATIC PIPE BURSING / SPLITTING .....</b>		<b>158</b>
<b>GENERAL .....</b>		<b>158</b>
33.05.25.01	SUMMARY .....	158
33.05.25.02	RELATED WORK.....	158
33.05.25.03	REFERENCES .....	158
33.05.25.04	SUBMITTALS .....	158
33.05.25.05	DEFINITIONS.....	159
33.05.25.06	QUALITY ASSURANCE .....	160

<b>PRODUCTS.....</b>	<b>160</b>
33.05.25.07    HIGH DENSITY POLYETHYLENE (HDPE).....	160
33.05.25.08    CASING SPACERS .....	162
<b>EXECUTION .....</b>	<b>162</b>
33.05.25.09    PUBLIC NOTIFICATION.....	162
33.05.25.10    SAFETY .....	162
33.05.25.11    GENERAL.....	163
33.05.25.12    INSTALLATION .....	163
<b>PRICE AND PAYMENT .....</b>	<b>165</b>
33.05.25.13    REPLACEMENT PIPE.....	165
33.05.25.14    RECONNECTION OF SERVICE LINES .....	165
33.05.25.15    CONNECTION TO MAINS .....	165
<b>SECTION 33.11.13 – POTABLE WATER DISTRIBUTION .....</b>	<b>166</b>
<b>GENERAL .....</b>	<b>166</b>
33.11.13.01    SUMMARY .....	166
33.11.13.02    RELATED WORK.....	166
33.11.13.04    SUBMITTALS .....	167
33.11.13.05    ACCEPTANCE .....	167
<b>PRODUCTS.....</b>	<b>168</b>
33.11.13.06    WATER DISTRIBUTION PIPE AND FITTINGS.....	168
33.11.13.07    GATE VALVES.....	169
33.11.13.08    VALVE BOXES.....	170
33.11.13.09    FIRE HYDRANTS .....	170
33.11.13.10    FLUSH HYDRANTS.....	172
33.11.13.11    AIR/VACUUM RELEASE VALVES AND PITS.....	172
33.11.13.12    WARNING TAPE.....	173
33.11.13.13    TRACER WIRE AND BOX .....	173
33.11.13.14    UTILITY MARKERS.....	173
33.11.13.15    POLYETHYLENE ENCASEMENT .....	173
33.11.13.16    WATER TESTING LAB .....	173
33.11.13.17    ACCESSORIES .....	174
<b>EXECUTION .....</b>	<b>174</b>
33.11.13.18    WATER MAIN INSTALLATION .....	174



33.11.13.19	GATE VALVE INSTALLATION .....	178
33.11.13.20	HYDRANT INSTALLATION .....	178
33.11.13.21	FLUSH RISER INSTALLATION .....	179
33.11.13.22	AIR/VACUUM RELEASE VALVE AND PIT INSTALLATION .....	179
33.11.13.23	WARNING TAPE INSTALLATION .....	180
33.11.13.24	TRACER WIRE AND BOX INSTALLATION .....	180
33.11.13.25	UTILITY MARKER INSTALLATION .....	181
33.11.13.26	PRESSURE AND LEAKAGE TESTING – PVC .....	181
33.11.13.27	PRESSURE AND LEAKAGE TESTING – DUCTILE IRON .....	182
33.11.13.28	PRESSURE AND LEAKAGE TESTING – PE .....	183
33.11.13.29	DISINFECTION OF WATER MAIN AND FITTINGS.....	184
33.11.13.30	CONNECTIONS TO EXISTING DISTRIBUTION SYSTEMS.....	184
<b>PRICE AND PAYMENT .....</b>		<b>185</b>
33.11.13.31	WATER MAIN.....	185
33.11.13.32	WATER MAIN APPURTENANCES .....	185
<b>SECTION 33.11.15 – WATER SERVICE LINE .....</b>		<b>186</b>
<b>GENERAL .....</b>		<b>186</b>
33.11.15.01	SUMMARY .....	186
33.11.15.02	RELATED WORK .....	186
33.11.15.03	REFERENCES .....	186
33.11.15.05	PRODUCT DELIVERY, STORAGE, AND HANDLING .....	186
<b>PRODUCTS.....</b>		<b>187</b>
33.11.15.06	PIPE.....	187
33.11.15.07	VALVES .....	187
33.11.15.08	MISC. ....	187
<b>EXECUTION .....</b>		<b>190</b>
33.11.15.09	EXCAVATION, TRENCHING, AND BACKFILLING .....	191
33.11.15.10	PIPE AND FITTINGS.....	191
33.11.15.11	TESTING AND DISINFECTION .....	192
<b>PRICE AND PAYMENT .....</b>		<b>192</b>
33.11.15.12	WATER SERVICE CONNECTION (if applicable).....	192
33.11.15.13	WATER SERVICE LINE .....	192
33.11.15.14	WATER SERVICE CURB STOP .....	192

33.11.15.15	WATER SERVICE METER PIT .....	193
<b>SECTION 33.11.50 – POTABLE WATER METER MANHOLE.....</b>		<b>194</b>
<b>GENERAL .....</b>		<b>194</b>
33.11.50.01	SUMMARY .....	194
33.11.50.02	RELATED WORK.....	194
33.11.50.03	REFERENCES .....	194
33.11.50.04	SUBMITTALS.....	195
33.11.50.05	DEFINITIONS.....	195
<b>PRODUCTS.....</b>		<b>195</b>
33.11.50.06	MANHOLES.....	195
33.11.50.07	FRAMES AND COVERS .....	195
33.11.50.08	WATER METER .....	196
33.11.50.09	WATER METER SUPPORTS .....	196
33.11.50.10	SPOOLS.....	196
<b>EXECUTION .....</b>		<b>196</b>
33.11.50.11	INSTALLATION .....	196
33.11.50.12	PRESSURE AND LEAKAGE TESTING.....	197
<b>PRICE AND PAYMENT.....</b>		<b>197</b>
33.11.50.13	WATER METER VAULT MANHOLE.....	197
33.11.50.14	ADDITIONAL FEET OF MANHOLE .....	197
<b>SECTION 33.31.13 – SANITARY SEWER MAIN .....</b>		<b>198</b>
<b>GENERAL .....</b>		<b>198</b>
33.31.13.01	SUMMARY .....	198
33.31.13.02	RELATED WORK .....	198
33.31.13.03	REFERENCES .....	198
33.31.13.04	SUBMITTALS .....	198
33.31.13.05	ACCEPTANCE .....	199
<b>PRODUCTS.....</b>		<b>199</b>
33.31.13.06	SEWER PIPE .....	199
33.31.13.07	SEWER APPURTENANCES.....	200
<b>EXECUTION.....</b>		<b>200</b>
33.31.13.08	CONTINUITY OF SERVICE.....	200
33.31.13.09	EXAMINATION.....	201

33.31.13.10	UTILITY CONFLICTS .....	201
33.31.13.11	SEWER MAIN INSTALLATION.....	201
33.31.13.12	ABANDONMENT .....	201
33.31.13.13	SEWER MAIN TESTING .....	202
<b>PRICE AND PAYMENT .....</b>		<b>207</b>
33.31.13.14	SEWER MAIN .....	207
33.31.13.15	SEWER MAIN CLEANOUT .....	207
<b>SECTION 33.31.15 – SANITARY SEWER SERVICE LINES .....</b>		<b>208</b>
<b>GENERAL .....</b>		<b>208</b>
33.31.15.01	SUMMARY .....	208
33.31.15.02	RELATED WORK.....	208
33.31.15.03	REFERENCES .....	208
33.31.15.04	SUBMITTALS.....	208
33.31.15.05	ACCEPTANCE .....	209
<b>PRODUCTS.....</b>		<b>209</b>
33.31.15.06	SEWER PIPE .....	209
33.31.15.07	SEWER APPURTENANCES.....	210
33.31.15.08	TRACER WIRE .....	210
<b>EXECUTION .....</b>		<b>210</b>
33.31.15.09	EXAMINATION.....	210
33.31.15.10	UTILITY CONFLICTS.....	210
33.31.15.11	SEWER SERVICE LINE INSTALLATION.....	210
33.31.15.12	TRACER WIRE INSTALLATION .....	212
33.31.15.13	INSPECTION .....	212
<b>PRICE AND PAYMENT .....</b>		<b>213</b>
33.31.15.14	SEWER SERVICE LINE .....	213
33.31.15.15	SEWER MAIN CLEANOUT .....	213
<b>SECTION 33.31.20 – SANITARY SEWER MAIN CLEANING AND INSPECTION .....</b>		<b>214</b>
<b>GENERAL .....</b>		<b>214</b>
33.31.20.01	SUMMARY .....	214
33.31.20.02	SCOPE .....	214
33.31.20.03	SUBMITTALS.....	214
<b>EXECUTION.....</b>		<b>215</b>

33.31.20.04	GENERAL.....	215
33.31.20.05	SEWER AND MANHOLE CLEANING .....	215
33.31.20.06	SEWER INSPECTION.....	217
<b>PRICE AND PAYMENT .....</b>		<b>224</b>
33.31.20.07	SEWER MAIN CLEANING AND INSPECTION.....	224
33.31.20.08	SEWER MANHOLE CLEANING AND INSPECTION.....	224
<b>SECTION 33.41.13 – STORM SEWER PIPING.....</b>		<b>225</b>
<b>GENERAL .....</b>		<b>225</b>
33.41.13.01	SUMMARY .....	225
33.41.13.02	RELATED WORK .....	225
33.41.13.03	REFERENCES .....	225
33.41.13.04	SUBMITTALS .....	226
33.41.13.05	ACCEPTANCE .....	226
<b>PRODUCTS.....</b>		<b>226</b>
33.41.13.06	MATERIALS .....	226
<b>EXECUTION.....</b>		<b>227</b>
33.41.13.07	CONSTRUCTION REQUIREMENTS.....	227
33.41.13.08	UTILITY CONFLICTS .....	227
33.41.13.09	INSPECTION .....	227
<b>PRICE AND PAYMENT .....</b>		<b>228</b>
33.41.13.10	METHOD OF MEASUREMENT.....	228
33.41.13.11	BASIS OF PAYMENT .....	228
<b>SECTION 33.44.13 – STORM SEWER INLETS .....</b>		<b>229</b>
<b>GENERAL .....</b>		<b>229</b>
33.44.13.01	SUMMARY .....	229
33.44.13.02	RELATED WORK.....	229
33.44.13.03	REFERENCES .....	229
33.44.13.04	SUBMITTALS .....	229
<b>PRODUCTS.....</b>		<b>229</b>
33.44.13.05	INLETS.....	229
33.44.13.06	CONCRETE .....	230
33.44.13.07	CASTINGS.....	230
33.44.13.08	STEEL REINFORCEMENT .....	230

33.44.13.09	MORTAR .....	230
33.44.13.10	CURING COMPOUND .....	230
33.44.13.11	INLET AND OUTLET PIPING .....	230
<b>EXECUTION .....</b>		<b>231</b>
33.44.13.12	INSTALLATION .....	231
<b>PRICE AND PAYMENT .....</b>		<b>232</b>
33.44.13.13	METHOD OF MEASUREMENT .....	232
33.44.13.14	BASIS FOR PAYMENT .....	232
<b>SECTION 33.49.13 – SANITARY SEWER MANHOLES.....</b>		<b>233</b>
<b>GENERAL .....</b>		<b>233</b>
33.49.13.01	SUMMARY .....	233
33.49.13.02	RELATED WORK.....	233
33.49.13.03	REFERENCES .....	233
33.49.13.04	SUBMITTALS.....	233
33.49.13.05	DEFINITIONS.....	234
<b>PRODUCTS.....</b>		<b>234</b>
33.49.13.06	MANHOLES.....	234
33.49.13.07	FRAMES AND COVERS .....	235
<b>EXECUTION .....</b>		<b>235</b>
33.49.13.08	INSTALLATION .....	235
33.49.13.09	ABANDONMENT.....	240
33.49.13.10	INSPECTION .....	240
33.49.13.11	TESTING .....	241
<b>PRICE AND PAYMENT .....</b>		<b>244</b>
33.49.13.12	STANDARD MANHOLES.....	244
33.49.13.13	ADDITIONAL FEET OF MANHOLE .....	244
33.49.13.14	SHALLOW MANHOLES.....	244
33.49.13.15	DROP MANHOLES.....	244
33.49.13.16	CONNECTION TO EXISTING MANHOLES .....	244
<b>STANDARD DETAIL M01 – TRENCH -TYPICAL AND ALTERNATE.....</b>		<b>245</b>
<b>DETAIL W01-GATE VALVE &amp; BOX .....</b>		<b>245</b>
<b>DETAIL W02-HYDRANT WITH GATE VALVE &amp; BOX .....</b>		<b>246</b>
<b>DETAIL W03-FLUSH RISER.....</b>		<b>247</b>

DETAIL W04-AIR VACUUM RELEASE VALVE PIT .....	248
DETAIL W05-AIR VACUUM RELEASE PIT-COVER.....	249
DETAIL W06-WATER SERVICE METER PIT .....	250
DETAIL S01-STANDARD SEWER MANHOLE .....	251
DETAIL S02-SHALLOW MANHOLE SECTION.....	252
DETAIL S03-TYPICAL DROP MANHOLE.....	253
DETAIL S04-SEWER MAIN CLEANOUT.....	254
<b>DETAIL S06-SEWER SERVICE RISER</b> .....	255
DETAIL S07-SEWER SERVICE CONNECTION STUB .....	256
DETAIL S08-SEWER SERVICE CLEANOUT .....	257
DETAIL S09-SEWER SERVICE CLEANOUT AT BEND.....	258
DETAIL M01-TRENCH-TYPICAL & ALTERNATE .....	259
DETAIL M02-THRUST BLOCK SETTINGS.....	260
DETAIL M03-UTILITY MARKER & INSTALLATION .....	261
DETAIL M04-HIGHWAY CROSSING .....	262
DETAIL RC001-CULVERT-RCP-ROUND.....	263
DETAIL RC002-CULVERT-RCP-ARCH.....	264
DETAIL RC003-CULVERT-RCP BEND-ROUND (SHORT).....	265
DETAIL RC004-CULVERT-RCP BEND-ROUND (LONG) .....	266
DETAIL RC005-CULVERT-RCP FLARED ENDS-ROUND .....	267
DETAIL RC006-CULVERT-RCP FLARED ENDS-ARCH .....	268
DETAIL RC007-CULVERT-RCP SAFETY ENDS .....	269
DETAIL RC008-CULVERT-RCP SLOPED ENDS-ROUND .....	270
DETAIL RC009-CULVERT-RCP SLOPED ENDS-ARCH .....	271
DETAIL RC010-CULVERT-RCP SLOPED END BAR ASSEMBLY-1 .....	272
DETAIL RC011-CULVERT-RCP SLOPED END BAR ASSEMBLY-2 .....	273
DETAIL RC012-CULVERT-RCP SECTIONAL ENDS-ROUND .....	274
DETAIL RC013-CULVERT-RCP SECTIONAL ENDS-ARCH .....	275
DETAIL RC014-CULVERT-RCP TIE BOLTS.....	276
DETAIL RC020-CULVERT-CMP-ARCH.....	277
DETAIL RC021-CULVERT-CMP SLOTTED DRAIN-1 .....	278
DETAIL RC022-CULVERT-CMP SLOTTED DRAIN-2 .....	279
DETAIL RC023-CULVERT-CMP ELBOWS.....	280

DETAIL RC024-CULVERT-CMP FLARED ENDS-ROUND .....	281
DETAIL RC025-CULVERT-CMP FLARED ENDS-ARCH .....	282
DETAIL RC026-CULVERT-CMP SLOPED ENDS-1.....	283
DETAIL RC027-CULVERT-CMP SLOPED ENDS-2.....	284
DETAIL RC028-CULVERT-CMP-RCP TRANSITIONS.....	285
DETAIL RC029-CULVERT-CMP SMOOTH TAPERED SLEEVE .....	286
DETAIL RC040-CULVERT-PRECAST BOX BARREL TIE.....	287
DETAIL RC041-CULVERT-PRECAST BOX TIE BOLT ASSEMBLY .....	288
DETAIL RC042-CULVERT-PRECAST BOX SLOPED END SECTION.....	289
DETAIL RC045-CULVERT-PRECAST DOUBLE BOX WITH SLOPED END-2' CUTOFF WALL.....	290
DETAIL RC046-CULVERT-PRECAST DOUBLE BOX WITH SLOPED END-4' CUTOFF WALL.....	291
DETAIL RC050-CULVERT-SLOPE TRANSITIONS-TYPE-1 .....	292
DETAIL RC051-CULVERT-SLOPE TRANSITIONS-TYPE-2 .....	293
DETAIL RD001-DROP INLET-CONCRETE-TYPE B (2X3)-1 .....	294
DETAIL RD002-DROP INLET-CONCRETE-TYPE B (2X3)-2 .....	295
DETAIL RD003-DROP INLET-CONCRETE-TYPE B (3X4)-1 .....	296
DETAIL RD004-DROP INLET-CONCRETE-TYPE B (3X4)-2 .....	297
DETAIL RD005-DROP INLET-CONCRETE-TYPE B (3X5.5)-1 .....	298
DETAIL RD006-DROP INLET-CONCRETE-TYPE B (3X5.5)-2 .....	299
DETAIL RD007-DROP INLET-CONCRETE-TYPE B (4X4)-1 .....	300
DETAIL RD008-DROP INLET-CONCRETE-TYPE B (4X4)-2 .....	301
DETAIL RD009-DROP INLET-CONCRETE-TYPE B (5.5X3)-1 .....	302
DETAIL RD010-DROP INLET-CONCRETE-TYPE B (5.5X3)-2 .....	303
DETAIL RD011-DROP INLET-CONCRETE-TYPE B (5.5X5.5)-1 .....	304
DETAIL RD012-DROP INLET-CONCRETE-TYPE B (5.5X5.5)-2 .....	305
DETAIL RD013-DROP INLET-CONCRETE-TYPE B (4X3)-1 .....	306
DETAIL RD014-DROP INLET-CONCRETE-TYPE B (4X3)-2 .....	307
DETAIL RD015-DROP INLET-CONCRETE-TYPE C (3X4)-1 .....	308
DETAIL RD016-DROP INLET-CONCRETE-TYPE C (3X4)-2 .....	309
DETAIL RD017-DROP INLET-CONCRETE-TYPE C (4X5)-1 .....	310
DETAIL RD018-DROP INLET-CONCRETE-TYPE C (4X5)-2 .....	311
DETAIL RD019-DROP INLET-CONCRETE-TYPE S (4X6)-1 .....	312
DETAIL RD020-DROP INLET-CONCRETE-TYPE S (4X6)-2 .....	313

DETAIL RD021-DROP INLET-CONCRETE-TYPE S (4X6)-3 .....	314
DETAIL RD022-DROP INLET-CONCRETE-TYPE S (4X11)-1.....	315
DETAIL RD023-DROP INLET-CONCRETE-TYPE S (4X11)-2.....	316
DETAIL RD024-DROP INLET-CONCRETE-TYPE S (4X11)-3.....	317
DETAIL RD025-DROP INLET-CONCRETE-TYPE S (7X11)-1.....	318
DETAIL RD026-DROP INLET-CONCRETE-TYPE S (7X11)-2.....	319
DETAIL RD027-DROP INLET-CONCRETE-TYPE S (7X11)-3.....	320
DETAIL RD028-DROP INLET-CONCRETE-TYPE S (7X11)-4.....	321
DETAIL RD029-DROP INLET-CONCRETE-TYPE S-INSTALLATION-1 .....	322
DETAIL RD030-DROP INLET-CONCRETE-TYPE S-INSTALLATION-2 .....	323
DETAIL RD031-DROP INLET-CONCRETE-TYPE B-INSTALLATION.....	324
DETAIL RD032-DROP INLET-CONCRETE-TYPE B-FRAME AND GRATE ASSEMBLY .....	325
DETAIL RD033-DROP INLET-CONCRETE-TYPE C-FRAME AND GRATE ASSEMBLY .....	326
DETAIL RD034-DROP INLET-CONCRETE-TYPE E-FRAME AND GRATE ASSEMBLY .....	327
DETAIL RD040-DROP INLET-CONCRETE-PERMANENT COVERS-1.....	328
DETAIL RD040-DROP INLET-CONCRETE-PERMANENT COVERS-2.....	329
DETAIL RD042-DROP INLET-CONCRETE-PRECAST COLLAR .....	330
DETAIL RD050-DROP INLET-MANHOLE FRAME AND LID-TYPE A.....	331
DETAIL RD051-DROP INLET-MANHOLE FRAME AND LID-TYPE B .....	332
DETAIL RD060-HEADWALL-CONCRETE-UNDERDRAIN .....	333
DETAIL RE001-EROSION CONTROL-BLANKET .....	334
DETAIL RE002-EROSION CONTROL-BALES .....	335
DETAIL RE003-EROSION CONTROL-ROCK CHECK DAM .....	336
DETAIL RE004-EROSION CONTROL-SILT FENCE-1 .....	337
DETAIL RE005-EROSION CONTROL-SILT FENCE-2 .....	338
DETAIL RE006-EROSION CONTROL-WATTLE-1 .....	339
DETAIL RE007-EROSION CONTROL-WATTLE-2 .....	340
DETAIL RE008-EROSION CONTROL-INLETS-1.....	341
DETAIL RE009-EROSION CONTROL-INLETS-2.....	342
DETAIL RE020-EROSION CONTROL-GABION-1 .....	343
DETAIL RE021-EROSION CONTROL-GABION-2 .....	344
DETAIL RE022-EROSION CONTROL-GABION-3 .....	345
DETAIL RE030-EROSION CONTROL-DITCH .....	346



<b>DETAIL RE031-EROSION CONTROL-SLOPE DRAIN.....</b>	<b>347</b>
<b>DETAIL RE032-EROSION CONTROL-SURFACE ROUGHENING.....</b>	<b>348</b>
<b>DETAIL RF001-FENCING-RIGHT-OF-WAY.....</b>	<b>349</b>
<b>DETAIL RF002-FENCING INSTALLATION .....</b>	<b>350</b>
<b>DETAIL RF003-FENCING-BRACE PANEL AND APPLICATIONS .....</b>	<b>351</b>
<b>DETAIL RF004-FENCING-BRACE PANEL APPLICATIONS AT STRUCTURES.....</b>	<b>352</b>
<b>DETAIL RF005-FENCING-WIDE DEPRESSIONS AND STREAM CROSSINGS .....</b>	<b>353</b>
<b>DETAIL RF006-FENCING-GROUNDING .....</b>	<b>354</b>
<b>DETAIL RF010-FENCING-WIRE GATES .....</b>	<b>355</b>
<b>DETAIL RF011-FENCING-TUBULAR FRAME GATES .....</b>	<b>356</b>
<b>DETAIL RF020-FENCING-ANCHORS FOR BOX CULVERT WING WALLS.....</b>	<b>357</b>
<b>DETAIL RF021-FENCING-ANCHORS FOR BRIDGE ABUTMENT WING WALLS (&gt;6') .....</b>	<b>358</b>
<b>DETAIL RF022-FENCING-ANCHORS FOR BRIDGE ABUTMENT WING WALLS (≤6') .....</b>	<b>359</b>
<b>DETAIL RF023-FENCING-ANCHORS FOR BRIDGE ABUTMENT WITH SWEEPED BACK WINGS .....</b>	<b>360</b>
<b>DETAIL RG001-CURB &amp; GUTTER-TYPE B.....</b>	<b>361</b>
<b>DETAIL RG002-CURB &amp; GUTTER-TYPE BL.....</b>	<b>362</b>
<b>DETAIL RG003-CURB &amp; GUTTER-TAPER .....</b>	<b>363</b>
<b>DETAIL RG004-CURB &amp; GUTTER-TYPE P.....</b>	<b>364</b>
<b>DETAIL RG005-CURB &amp; GUTTER-VALLEY.....</b>	<b>365</b>
<b>DETAIL RG006-CURB &amp; GUTTER-JOINTS-1 .....</b>	<b>366</b>
<b>DETAIL RG007-CURB &amp; GUTTER-JOINTS-2 .....</b>	<b>367</b>
<b>DETAIL RG010-CURB &amp; GUTTER-CURB RAMP-PERPENDICULAR-1.....</b>	<b>368</b>
<b>DETAIL RG011-CURB &amp; GUTTER-CURB RAMP-PERPENDICULAR-2.....</b>	<b>369</b>
<b>DETAIL RG012-CURB &amp; GUTTER-CURB RAMP-PERPENDICULAR-3.....</b>	<b>370</b>
<b>DETAIL RG013-CURB &amp; GUTTER-CURB RAMP-DIRECTIONAL-1.....</b>	<b>371</b>
<b>DETAIL RG014-CURB &amp; GUTTER-CURB RAMP-DIRECTIONAL-2.....</b>	<b>372</b>
<b>DETAIL RG015-CURB &amp; GUTTER-CURB RAMP-DIRECTIONAL-3.....</b>	<b>373</b>
<b>DETAIL RG016-CURB &amp; GUTTER-CURB RAMP-PARALLEL-1 .....</b>	<b>374</b>
<b>DETAIL RG017-CURB &amp; GUTTER-CURB RAMP-PARALLEL-2 .....</b>	<b>375</b>
<b>DETAIL RG018-CURB &amp; GUTTER-CURB RAMP-PARALLEL-3 .....</b>	<b>376</b>
<b>DETAIL RG030-CURB &amp; GUTTER-OPENING AND TRANSITIONS FOR FUTURE CURB RAMP-1.....</b>	<b>377</b>
<b>DETAIL RG031-CURB &amp; GUTTER-OPENING AND TRANSITIONS FOR FUTURE CURB RAMP-2.....</b>	<b>378</b>
<b>DETAIL RL001-LIGHTING-DETECTOR LOOP-PREFORMED .....</b>	<b>379</b>

DETAIL RL002-LIGHTING-DETECTOR LOOP-SAWED IN .....	380
.....	380
DETAIL RL003-LIGHTING-DETECTOR LOOP-SAWED IN PCC .....	381
DETAIL RL004-LIGHTING-CONDUCTOR CABLES-CONDUIT .....	382
DETAIL RL005-LIGHTING-CONDUCTOR CABLES-DIRECT BURY.....	383
DETAIL RR001-RAILROAD-PAVEMENT MARKINGS AT CROSSINGS .....	384
DETAIL RR002-RAILROAD-TYPICAL APPROACH .....	385
DETAIL RR003-RAILROAD-EXCAVATION PROFLES .....	386
DETAIL RR010-RAILROAD-DETECTABLE SIDEWALK WARNINGS ADJACENT TO CROSSINGS-1 .....	387
DETAIL RR011-RAILROAD-DETECTABLE SIDEWALK WARNINGS ADJACENT TO CROSSINGS-2 .....	388
DETAIL RS001-SIDEWALK-CONCRETE-1 .....	389
DETAIL RS002-SIDEWALK-CONCRETE-2 .....	390
DETAIL RS010-SIDEWALK-DRAIN .....	391
DETAIL RS011-SIDEWALK-ADJACENT TO TYPE S DROP INLET LID-1 .....	392
DETAIL RS012-SIDEWALK-ADJACENT TO TYPE S DROP INLET LID-2 .....	393
DETAIL RW001-CONCRETE RETAINING WALL-TYPE C-1 .....	394
DETAIL RW002-CONCRETE RETAINING WALL-TYPE C-2 .....	395

## SECTION 01.00.00 – REFERENCES

### GENERAL

#### 01.00.00.01 SUMMARY

- A. This section includes a list of organizations, associations, and agencies, with jurisdiction that have references, standards, laws, or regulations cited in these specifications.
- B. Use the latest revision of all references, standards, laws, or regulations.

#### 01.00.00.02 LIST OF ORGANIZATIONS AND ASSOCIATIONS

##### A. National Standards Organizations & Associations

American Association of State Highway and Transportation Officials (AASHTO)  
444 North Capital Street NW, Suite 249  
Washington DC, 20001  
(202) 624-5800

American Concrete Institute (ACI)  
38800 County Club Drive  
Farmington Hills, MI 48331  
(248)-848-3700

American Society for Testing and Materials (ASTM)  
100 Barr Harbor Drive  
PO Box C700  
West Conshohocken, PA 19428-2959  
(610) 832-9500

American Water Works Association (AWWA)  
6666 West Quincy Avenue  
Denver, CO 80235  
(303) 794-7711

National Electric Code (NEC)  
National Fire Protection Association  
1 Batterymarch Park  
Quincy, MA 02169-7471  
(617) 770-3000

National Electrical Manufacturer's Association (NEMA)  
1300 North 17th Street, Suite 1752  
Rosslyn, VA 22209  
(703) 841-3200

Underwriters' Laboratories, Inc. (UL)  
333 Pfingston Road  
Northbrook, IL 60062-2096  
(847) 272-8800

American National Standards Institute (ANSI)  
819 I Street NW, 6<sup>th</sup> Floor  
Washington, DC 20036  
(202) 293-8020

National Sanitation Foundation International (NSF)  
PO Box 130140  
789 North Dixboro Road  
Ann Arbor, MI 48113-0140  
(734) 769-8010

Joint Transportation Research Program (JTRP)  
Hall for Discovery and Learning Research,  
Rm 204  
207 S Martin Jischke Dr  
West Lafayette, IN 47907  
(765) 494-6508

## B. Federal Departments and Agencies

US Environmental Protection Agency  
(EPA) – Region 8  
80C-EISC  
1595 Wynkoop Street  
Denver, CO 80202-1129  
(303) 312-6312

US Department of Labor  
Occupational Safety and Health  
Administration (OSHA) – Region 8  
Regional Office  
1999 Broadway, Suite 1690  
Denver, CO 80202  
(720) 264-6550

*Manual on Uniform Traffic Control Devices*  
Federal Highway Administration  
1200 New Jersey Avenue, SE  
Washington, DC 20590  
(202) 366-4000

## C. State Agencies

South Dakota Department of Agriculture  
and Natural Resources (SDDANR)  
PMB 2020  
Joe Foss Building  
Pierre, SD 57501  
(605) 773-3151

South Dakota Department of Transportation  
(SDDOT)  
700 East Broadway Avenue  
Becker-Hansen Building  
Pierre, SD 57501  
(605) 773-3265

**END OF SECTION**

## SECTION 01.31.13 – PROJECT MANAGEMENT AND COORDINATION

### GENERAL

#### 01.31.13.01 SUMMARY

- A. This section includes the preconstruction conference, construction scheduling, and coordination requirements.

#### 01.31.13.02 PRE-CONSTRUCTION CONFERENCE

- A. Required after award of contract and prior to start of construction.
- B. Representatives from the following shall attend.
  - i. Prime Contractor and any Subcontractors
  - ii. Engineer and any Technical Representative(s)
- C. The Engineer will arrange a date that is mutually acceptable to all parties planning to attend.
- D. Contractor shall notify subcontractors of time and date of meeting.

#### 01.31.13.03 CONSTRUCTION SCHEDULE

- A. Present Project Engineer with a written preliminary construction schedule containing start and completion dates of the major items at the preconstruction meeting.
- B. Notify the Project Engineer three full working days in advance of any construction.
- C. Communicate major changes to the schedule to the Project Engineer in writing.

#### 01.31.13.04 WORKING HOURS/DAYS

- A. Except as required for safety purposes, all work shall be performed during regularly scheduled working hours. The Contractor shall not work on Saturday, Sunday, or a Federal holiday without the Owner and Project Engineer's consent.

#### 01.31.13.05 COORDINATION WITH OTHER CONTRACTORS/UTILITIES

- A. Coordinate work with other contractors (i.e. roads, building, etc.) in the area as necessary to complete the work specified.
- B. Coordinate work with local utilities (i.e. water and sewer, power, telephone). Note: all buried utilities may not be shown on the plans. It is the Contractor's responsibility for having utilities marked prior to construction.

01.31.13.06 COORDINATION WITH OWNER'S REPRESENTATIVE

- A. Owner will provide contractor with contact information of Owners' representative for the project. Contractor will make all communications to the Owner thru the authorized representative.

**END OF SECTION**

## SECTION 01.31.15 – SUBMITTAL PROCEDURES

### GENERAL

#### 01.31.15.01 SUMMARY

- A. This section includes information on submittal procedures. Materials requiring submittal are listed in the appropriate specification section.

#### 01.31.15.02 SUBMITTAL PROCEDURES

- A. Submit 3 hardcopies or 1 electronic copy of submittals to the Engineer, unless requested otherwise.
- B. Identify each cut sheet or shop drawing with the following information:
  - i. Contract number.
  - ii. Supplier.
  - iii. Specification section to which the submittal pertains.
- C. Submit the following information, as applicable:
  - i. Manufacturer's cut sheets indicating compliance with references (e.g. applicable ASTM, AWWA standards).
  - ii. Laboratory results, as applicable.
  - iii. Dimensional drawings or shop drawings, as applicable.
  - iv. Other information necessary for the Project Engineer to determine compliance with the specifications.
- D. Identify variations from the contract documents and product or system limitations that may be detrimental to successful performance of the completed work.
- E. Revise and resubmit submittals as required and identify all changes made since previous submittal.
- F. Distribute copies of reviewed submittals to concerned parties, (i.e. suppliers, sub-contractors).
- G. Submit written communication of any inability to comply with the Engineer's comments.
- H. Submit information to the Engineer at least three weeks in advance of the work to be performed.
- I. Approval of submittals must be provided by the Engineer prior to installation of materials.

**END OF SECTION**

## SECTION 01.45.23 – QUALITY REQUIREMENTS

### GENERAL

#### 01.45.23.01 SUMMARY

- A. This section includes prerequisites and procedures to assure quality construction.

#### 01.45.23.02 SUBMITTALS

- A. Contractor Name and License Number

#### 01.45.23.03 INSTALLER QUALIFICATIONS

- A. Work shall be performed under the direction of personnel licensed in the state where the project is proposed and where licensing of the trade is regulated by the state including, but not limited to, plumbing, well drilling, HVAC, and electrical work.

#### 01.45.23.04 CONTROL OF INSTALLATION

- A. Review materials for acceptability when delivered to the site.
- B. Store and handle materials to prevent damage.
- C. Review materials, services, and workmanship to ensure that work is performed in accordance with the specifications.
- D. Comply fully with manufacturers' instructions.
- E. Should manufacturers' instructions conflict with contract documents, request clarification from Project Engineer before proceeding.
- F. Correct defective work to the satisfaction of the Project Engineer.

#### 01.45.23.05 MANUFACTURER'S FIELD SERVICES

- A. Provide reports on project observations/documentation to the Project Engineer within 30 days of visit for review where manufacturers' field services are provided.

#### 01.45.23.06 WARRANTY

- A. Provide a minimum one (1) year warranty for all materials and labor, covering defects in the materials or deficiencies resulting from contractor installation.
- B. Provide additional warranties as required under other sections.

**END OF SECTION**



## SECTION 01.71.23 – STAKING AND CONSTRUCTION SURVEYING

### GENERAL

#### 01.71.23.01 SUMMARY

- A. This section outlines the staking and surveying work related to provide reference points in the field. The section clarifies staking provided to the Contractor and Contractor's responsibilities. Contractor shall employ an Owner approved, qualified, SD Registered Land surveyor or Engineer to provide all required project staking.

#### 01.71.23.02 RELATED WORK

- A. Section 31.11.10 – Site Clearing
- B. Section 31.14.13 – Earthwork
- C. Section 31.23.16 – Excavation, Trenching and Backfill

#### 01.71.23.03 STAKING PROVIDED TO THE CONTRACTOR

- A. Water Main Staking
  - i. Centerline staking (maximum every 100 feet).
  - ii. Appurtenance (gate valve, fittings, fire hydrant, etc.) staking on center with offset staking.
- B. Sewer Main and Appurtenance Staking
  - i. Offset centerline staking (maximum every 100 feet).
  - ii. Manhole staking on center with offset staking.
  - iii. Hubs for horizontal and vertical control at each manhole.
- C. Storm Sewer and Appurtenances Staking
  - i. Offset centerline staking (maximum every 100 feet).
  - ii. Manholes and inlet structures on center with offset staking.
  - iii. Hubs for horizontal and vertical control at each manhole or structure.
- D. Curb and Gutter Staking
  - i. Top Back of Curb offset staking for horizontal and vertical control (maximum of 25').
  - ii. Control points for all changes in alignment horizontal and vertical.

#### 01.71.23.04 CONTRACTOR'S RESPONSIBILITY

- A. Notify the Engineer at least 14 calendar days in advance of the times and places that pipeline staking will be needed.

- B. Provide supplementary staking, grade staking, offsets, temporary bench marks, and control points as necessary to complete the work in accordance with the plans and specifications.
- C. Request clarification from the Engineer regarding apparent conflicts before proceeding with installation of facilities.
- D. Preserve all reference staking, until such time as the pipeline or other facilities are installed.
  - i. Reference stakes needing replacement due to Contractor error or negligence must be replaced by Contractor, at no cost to the contract.
- E. All permanent survey points/markers (i.e. property corners) and benchmarks not directly in the line of work shall be preserved.
  - i. Replace all permanent survey markers disturbed or destroyed using a Professional Land Surveyor, at no cost to the contract.
  - ii. Provide evidence of re-establishment of permanent survey markers to the Engineer.

**END OF SECTION**

## SECTION 01.74.13 – CLOSEOUT PROCEDURES

### GENERAL

#### 01.74.13.01 SUMMARY

- A. Section includes information on closeout procedures and final cleanup.

#### 01.74.13.02 CLOSEOUT PROCEDURES

- A. Submit written certification that work is complete in accordance with contract documents and ready for final inspection at least three (3) working days prior to final inspection.
- B. Provide warranties and record documents (e.g. as-built drawings) to the Project Engineer within ten (10) days after date of Owner's formal acceptance of "Substantial Completion".

#### 01.74.13.03 FINAL CLEANING

- A. Complete final clean-up prior to final inspection.
- B. Remove waste and surplus materials, rubbish, and construction facilities from the site.
- C. Return all disturbed areas to a condition equal to or better than original condition.

#### 01.74.13.04 FINAL INSPECTION

- A. A final inspection of the facilities shall be conducted in the presence of the Project Engineer and the Contractor, at a minimum.
- B. Final inspection shall include inspection of all facilities installed under the project.
- C. No final inspection will be performed or scheduled until the Engineer stamped set of "As-Built" drawings have been received by the City.

#### 01.74.13.05 PUNCH LIST

- A. Any deficiencies noted at the final inspection will be communicated to the Contractor through a letter from the Project Engineer.
- B. All deficiency corrections must be completed before full payment is made.
- C. Retainage for punch list items shall be based on the estimated cost to retain another contractor to finish the deficient work items.

**END OF SECTION**

## SECTION 03.05.13 – CONCRETE

### GENERAL

#### 03.05.13.01 SUMMARY

- A. This section covers cast-in-place concrete, metal reinforcement, and concrete accessories used for structural cast-in-place concrete.

#### 03.05.13.02 RELATED WORK

- A. Section 03.11.13 – Concrete Forms

#### 03.05.13.03 REFERENCES

- A. ACI 301 – Specifications for Structural Concrete
- B. ACI 305R – Hot Weather Concreting
- C. ACI 306R – Cold Weather Concreting
- D. ACI 309 – Guide for Consolidation of Concrete
- E. ACI 318 – Building Code Requirements for Structural Concrete
- F. ACI 350 – Environmental Engineering Concrete Structures
- G. ASTM A82 – Standard Specification for Cold Drawn Steel Wire, Plain, for Concrete Reinforcement
- H. ASTM A184 – Standard Specification for Fabricated Deformed Steel Bar Mats for Concrete Reinforcement
- I. ASTM A185 – Standard Specification for Steel Welded Wire Reinforcement, Plain, for Concrete
- J. ASTM A493 – Standard Specification for Stainless Steel Wire and Wire Rods for Cold Heading and Cold Forging
- K. ASTM A496 – Standard Specification for Steel Wire, Deformed, for Concrete Reinforcement
- L. ASTM A615 – Standard Specification for Deformed and Plain Carbon-Steel Bars for Concrete Reinforcement
- M. ASTM A706 – Standard Specification for Low-Alloy Steel Deformed and Plain Bars for Concrete Reinforcement

- N. ASTM A775 – Standard Specification for Epoxy-Coated Steel Reinforcing Bars
- O. ASTM A996 – Standard Specification for Rail-Steel and Axle-Steel Deformed Bars for Concrete Reinforcement
- P. ASTM C33 – Standard Specification for Concrete Aggregates
- Q. ASTM C55 – Standard Specification for Concrete Building Brick
- R. ASTM C94 – Standard Specification for Ready Mixed Concrete
- S. ASTM C1116 / C1116M – Standard Specification for Fiber-Reinforced Concrete
- T. ASTM C150 – Standard Specification for Portland Cement
- U. ASTM C233 – Standard Test Method for Air-Entraining Admixtures for Concrete
- V. ASTM C260 – Standard Specification for Air-Entraining Admixtures for Concrete
- W. ASTM C309 – Standard Specification for Liquid Membrane-Forming Compounds for Curing Concrete
- X. ASTM C494 – Standard Specification for Chemical Admixtures for Concrete
- Y. ASTM D994 – Standard Specification for Preformed Expansion Joint Filler for Concrete (Bituminous Type)
- Z. ASTM D1248 – Standard Specification for Polyethylene Plastics Extrusion Materials For Wire and Cable
- AA. ASTM D1751 – Standard Specification for Preformed Expansion Joint Filler for Concrete Paving and Structural Construction (Nonextruding and Resilient Bituminous Types)
- BB. ASTM D1752 – Standard Specification for Preformed Sponge Rubber Cork and Recycled PVC Expansion Joint Fillers for Concrete Paving and Structural Construction
- CC. ASTM D6690 – Standard Specification for Joint and Crack Sealants, Hot Applied, for Concrete and Asphalt Pavements
- DD. CRSI – Concrete Reinforcing Steel Institute

#### 03.05.13.04 SUBMITTALS

- A. Reinforcing Steel: Test certificates of manufacturer’s laboratory, identifying chemical and physical analysis of each load of reinforcing steel.
- B. Concrete Mix Design
- C. Cement manufacturer’s certificates of conformance with ASTM C150.
- D. Product data for concrete admixtures.

- E. Location and type of control joints.
- F. Joint Filler
- G. Joint Sealant
- H. Waterstops

#### 03.05.13.05 QUALITY ASSURANCE

- A. Perform work in accordance with ACI 301.
- B. Obtain cement, aggregate, and admixtures from the same source for all work.

#### 03.05.13.06 FIELD QUALITY CONTROL

- A. Contractor is responsible for demonstrating compressive strength of concrete actually used in the completion of the work.
- B. Testing:
  - 1. Provide one slump test for each truck load delivered.
  - 2. Provide one set of cylinders for strength testing for each 100 cubic yards, unless directed otherwise by the Engineer.

### PRODUCTS

#### 03.05.13.07 REINFORCEMENT

- A. Grade and type as indicated on the plans.
- B. Reinforcing Bars.
  - 1. 60,000 psi minimum yield.
  - 2. Conform to ASTM A615.
  - 3. Epoxy coated reinforcing bars conform to ASTM A775.
- C. Wire Mesh.
  - 1. Conform to ASTM A185.
- D. Metal Bar Supports.
  - 1. Type 1, Standard: in accordance with current CRSI standard.
  - 2. Type 2, Stainless Steel Protected: ASTM A493.
  - 3. Type 3, Plastic Protected: ASTM D1248.
- E. Pre-cast Concrete Block Bar Supports.
  - 1. Type 1, Grade N: ASTM C55.
  - 2. Minimum 9 square inches of bearing area.
- F. Store on platforms, or other support to prevent contact with ground or surface water.

- G. Fiber-reinforced concrete reinforcement products shall conform to ASTM C1116/C1116M.

### 03.05.13.08 CONCRETE MATERIALS

#### A. Cement:

- 1. ASTM C150, Portland Cement Type – II.
- 2. Total alkali content less than 0.6%, expressed as Na<sub>2</sub>O equivalent.
- 3. Storage:
  - a. Suitable, dry, weatherproof buildings raised above the ground.
  - b. Weather-tight, moisture- and damp-proof bin.

#### B. Aggregates:

- 1. Fine Aggregates:
  - a. Conform to ASTM C33.
  - b. Fine aggregates shall be clean, hard, durable, uncoated, well rounded grains, preferably of siliceous materials.
- 2. Coarse Aggregates:
  - a. Conform to ASTM C33.
  - b. Coarse aggregates shall be clean, hard, durable, crushed limestone, trap rock, granite or other approved material.
  - c. 100% passing 1-inch screen for walls or slabs 6 inches or less.
  - d. 100% passing 1½-inch screen for walls or slabs greater than 6 inches.
- 3. Material Storage
  - a. Store materials in such a manner as to prevent deterioration or intrusion of foreign matter.

#### C. Mixing Water:

- 1. Use potable water unless approved by the Engineer.

#### D. Admixtures:

- 1. Water Reducing Type:
  - a. Conform to ASTM C494, Type A.
- 2. Air Entraining Type:
  - a. The admixture shall conform to ASTM C260 and be approved by the Engineer.
  - b. For concrete destined to experience repeated freeze and thaw cycles shall contain 4.5% - 7.5% entrained air.
  - c. Where the concrete is not required to experience freeze-thaw and is to receive a burnished finish, air entrainment admixtures shall be deleted from the mix.

#### E. Concrete Mix – unspecified:

- 1. Aggregate:
  - a. 1 ½-inch to 2-inch maximum aggregate: 4 – 6%
  - b. ¾-inch to 1-inch maximum aggregate: 5 – 7%
- 2. Concrete: 550 lbs per cubic yard.
- 3. Strength: 3500 psi at 28 days.
- 4. Slump: 3-inches +/- 1-inch.

#### F. Concrete Mix – M5:

1. Aggregate: 50% by weight coarse aggregate.
2. Concrete: 500 lbs per cubic yard.
3. Strength: 3000 psi at 28 days.
4. Slump: 3-inches +/- 1-inch.

G. Concrete Mix – M6:

1. Aggregate: 50% by weight coarse aggregate.
2. Concrete: 600 lbs per cubic yard.
3. Strength: 4000 psi at 28 days.
4. Slump: 3-inches +/- 1-inch.

H. Curing Materials:

1. Absorptive mat: Burlap fabric of 10 oz/sq. yd, clean, roll goods.
2. Absorptive mat: Burlap-polyethylene, 8 oz/sq. yd., bonded to prevent separation during use.
3. Membrane curing compound: Comply with ASTM C309.
4. Polyethylene film: 4 mil thick; clear or opaque color.

### 03.05.13.09 ACCESSORIES

A. Joint Filler.

1. Preformed expansion joint filler for concrete (bituminous type) ASTM D994.
2. Preformed expansion joint filler for concrete paving and structural construction (Nonextruding and resilient bituminous types) ASTM D1751.
3. Preformed sponge rubber and cork expansion joint fillers for concrete paving and structural concrete, ASTM D1752.

B. Joint Sealer.

1. Concrete joint sealer, hot-poured elastic type, ASTM D6690.

C. Waterstops.

1. Rubber material.
2. Minimum thickness of 3/8 inch.
3. Minimum width across joint: 9-inches for expansion joint; 6-inches for all others.

## EXECUTION

### 03.05.13.10 PLACEMENT OF REINFORCEMENT

- A. Place metal reinforcement accurately according to the plans.
- B. All joints or splices shall be made by using approved clamps, welding or by lapping the ends of the bars a distance of at least 40 times their nominal diameters unless otherwise noted on the plans.
- C. Lap adjoining wire mesh by no less than one full mesh and lace securely with wire.
- D. Avoid splicing at points of maximum stress.



- E. Accommodate placement of formed openings.
- F. Minimum distances shall be as follows:
  - 1. Wall Bars: 1-1/2 inch clear, 2 inch clear if exposed to weather or water.
  - 2. Slab Bottom and Top Bars: 3/4-inch clear, 2 inch clear if exposed to weather or water.
  - 3. Footing Top Bars: 2-inch clear.
  - 4. Footing Bottom Bars: 3-inch clear, unless otherwise noted.
  - 5. Beams and Column Bars: 1-1/2 inch clear, 2-inch if exposed to weather or water.
  - 6. Slab on Grade: Top bar 2-inch clear, bottom bar 3-inch clear.
- G. Lace reinforcement with wire, in accordance with current CRSI standard, to supports or reinforcing to prevent displacement during concrete placement.

#### 03.05.13.11 PLACING CONCRETE

- A. Install concrete at the location and to the dimensions shown on the drawings.
- B. Notify Project Engineer a minimum of 24 hours in advance of concrete placement.
- C. Assure placement and proper location of all reinforcement, embedded items, and accessories.
- D. Do not place concrete on frozen ground.
- E. Place concrete from mixing truck to final location quickly and without segregation.
- F. Place concrete continuously within 45 minutes of mixing with water, 90 minutes if admixture is used.
- G. Allowable vertical drop of concrete:
  - 1. 5 feet for 10-inch or thinner walls.
  - 2. One additional foot of drop for each inch of wall thickness over 10-inches.
  - 3. Maximum drop of 10 feet.
- H. Do not place concrete that has begun to set.
- I. Remove water from place of deposit before concrete is placed.
- J. Moisten subgrade at the time the concrete is placed.
- K. Deliver and mix Ready-Mixed Concrete in accordance with ASTM C94.
- L. Access to the mixing plant shall be provided to the Project Engineer.
- M. Tickets indicating time of adding initial mixing water may be required by the Project Engineer.
- N. Place concrete in one continuous operation
- O. Consolidate concrete using vibrator following ACI 309.

- P. Conform to ACI 305R for Hot Weather Concreting and ACI 306R for Cold Weather Concreting.
- Q. Use non-corrosive, non-chloride accelerator when placing concrete in air temperatures below 50 degrees Fahrenheit.

#### 03.05.13.12 CONCRETE FINISHING OF UNFORMED SURFACES

- A. Finish in accordance with ACI 301.
- B. Buried or permanently submerged concrete blocking and encasement will require no finishing except that necessary to obtain the required surface elevations.
- C. Screeding
  - 1. Provide concrete surfaces conforming to the proper elevation and contour with all aggregates completely embedded in mortar.
  - 2. Surfaces shall be free of irregularities with a height or depth in excess of ¼-inch.
- D. Floating
  - 1. Perform floating with hand floats or suitable mechanical floats.
  - 2. Give screeded surfaces an initial float finish as soon as the concrete has stiffened sufficiently for proper working.
  - 3. Remove and replace with mortar any aggregate causing surface irregularities.
  - 4. Follow initial floating with a second floating at the time of initial set.
  - 5. Provide a uniform texture and color with the second floating.
  - 6. Unless additional floating is required, the completed float finish will be provided by the second float finish.
- E. Troweling
  - 1. Trowel surfaces that will be exposed after construction is construction with a steel trowel.
  - 2. Trowel finishing is not required on floors that are normally submerged.
  - 3. Perform troweling after the second floating when the surface has hardened sufficiently to prevent an excess of fines being drawn to the surface.
  - 4. Produce a dark, smooth, uniform surface free from blemishes and trowel marks.
- F. Edging
  - 1. Edge floated or troweled surfaces with an edger (radius not exceeding 3/8-inch).

#### 03.05.13.13 CONCRETE FINISHING OF FORMED SURFACES

- A. Finish all formed surfaces in accordance with ACI 301 and ACI 318.
- B. Finish concrete after the removal of forms, as soon as the conditions will permit.
- C. Repair surfaces with mortar containing 1 part cement and 2 parts fine sand, by volume, using a wooden trowel.

#### 03.05.13.14 CONCRETE FINISHING OF FLOORS

- A. Finish all floors in accordance with ACI 301.
- B. Bring floor up to proper elevation and screed, making sure the floor is sloped a minimum of 2% toward floor drains.
- C. Give a minimum of 2 steel trowelings when concrete has set sufficiently.

#### 03.05.13.15 EMBEDDED ITEMS

- A. Install embedded items as shown on the drawings.
- B. Coordinate installation of embedded materials.
- C. Place anchor bolts, pipes, conduit, and other required items to secure.
- D. Pipes or conduit for embedment within a slab, wall or beam, other than those merely passing through, shall satisfy the following:
  - 1. Outside diameter less than 1/3 the thickness of the slab, wall, or beam.
  - 2. Spaced no closer than 3 diameters on center.
  - 3. Shall not impair the strength of the concrete.
- E. Temporarily fill voids in sleeves, inserts, and anchor slots with readily removable material to prevent entry of concrete into the voids.

#### 03.05.13.16 CUTTING HOLES

- A. Install holes at the locations and dimensions shown on the drawings.
- B. Core drill holes when approved.
- C. Any holes cut shall made with equipment designed for the application and properly used.

#### 03.05.13.17 ADMIXTURES

- A. Water Reducing Type
  - 1. Use in accordance to manufacturer's recommendations.
- B. Air Entraining Type
  - 1. Use in accordance to manufacturer's recommendations.
  - 2. Test in accordance with ASTM C233.

#### 03.05.13.18 CURING

- A. Membrane Curing Compound
  - 1. Apply compound in two coats with second coat at right angle to first.
  - 2. Apply according to manufacturer's instructions.

- B. Ponding
  - 1. Maintain 100% water coverage over concrete areas continuously for 3 days.
- C. Spraying
  - 1. Spray water over concrete areas; maintain wet for 3 days.
- D. Absorptive Mat
  - 1. Spread absorptive mat over slab areas.
  - 2. Lap edges and ends 12-inches.
  - 3. Spray with water until mat is saturated.
  - 4. Maintain saturation for 3 days.
- E. Polyethylene Film
  - 1. Spread polyethylene film over concrete.
  - 2. Lap edges and ends 3-inches and seal with pressure sensitive polyester tape.
  - 3. Maintain in place with plywood sheets for 3 days.
- F. Curing
  - 1. Cure concrete as scheduled.
  - 2. Remove absorptive mat or sheeting and ballast after curing.

#### 03.05.13.19 CONCRETE ACCESSORIES

- A. Preparation.
  - 1. Correct any defects or conflicts that will affect proper performance prior to placement of joint filler, joint sealer, or waterstops.
  - 2. Joint Sealants:
    - a. Prime surfaces in accordance with manufacturer's recommendations.
- B. Installation.
  - 1. Joint Fillers.
    - a. Install joint filler as indicated on the plans or as directed by the Project Engineer.
    - b. Install according to manufacturer's recommendations.
  - 2. Joint Sealants.
    - a. Do not seal joints when air or concrete temperature is below 40 degrees Fahrenheit.
    - b. Install bond breaker and backup material as indicated on the plans.
    - c. Install according to manufacturer's recommendations.
  - 3. Waterstops.
    - a. Locate as indicated on the plans in a manner to permanently retain flexibility.
    - b. Splice by heat sealing in length or at intersections, in accordance to manufacturer's recommendations.
    - c. Reform splices with a remodeling iron having ribs or corrugations to match the pattern of the waterstop.
    - d. Provide support, protection, and suitable guards for waterstops and partially embedded waterstops during the progression of work and after placement has discontinued.
    - e. Replace or repair any punctured or damaged waterstops.

### 03.05.13.20 DEFECTIVE CONCRETE

- A. Defective concrete is defined as concrete in place, which does not conform to the strength, shapes, alignments, appearances and/or elevation, as shown on the drawings and/or presents faulty surface areas.
- B. Concrete surfaces not finished or cured in accordance with specifications are classified as defective concrete.
- C. Defective concrete shall be removed and replaced at no additional cost.
- D. Formed surfaces larger or smaller than the specified dimensional tolerances shall be deemed defective concrete.
- E. If the Project Engineer permits the Contractor to correct the error, such correction shall be as directed and in such a manner as to maintain the strength, function, and appearance of the structure.
- F. Concrete members cast in the wrong location shall be rejected and shall be removed and recast at no additional cost.
- G. Inaccurately formed surfaces exposed to view may be rejected and shall be repaired or removed and replaced and no additional cost.
- H. Concrete exposed to view with defects which adversely affect the appearance of the specified finish shall be repaired.
- I. If the Project Engineer determines the defects cannot be repaired, the concrete shall be deemed defective and rejected.
- J. The strength of the structure in place will be considered defective if it meets any of the following requirements:
  - 1. Actual laboratory strength less than the strength specified.
  - 2. Reinforcing steel size, quantity, strength, position, or arrangement differs from the drawings.
  - 3. Concrete which differs from the required dimensions or locations in such a manner as to reduce the strength of the structure.

## PRICE AND PAYMENT

### 03.05.13.21 METHOD OF MEASUREMENT

- A. Except if specifically called out on the bid schedule, concrete will normally be incidental to the contract.
- B. If specifically called out on the bid schedule, measurement shall be made in the units shown on the bid schedule to the nearest tenth.

03.05.13.22 BASIS OF PAYMENT

- A. Except if specifically called out on the bid schedule, concrete will normally be incidental to the contract and no additional payment will be provided for this work.
- B. If specifically called out on the bid schedule, payment shall be made for the actual amount of work performed in the units shown on the bid schedule.
- C. Any payment made shall be full compensation for all materials, labor, equipment, and incidentals necessary to complete the work.

**END OF SECTION**

## SECTION 03.05.15 – LOW-DENSITY CELLULAR CONCRETE

### GENERAL

#### 03.05.15.01 SUMMARY

- A. This work shall consist of furnishing and placing a low-density cellular concrete (LDCC) material as shown on the drawings to fill and abandon existing pipelines and casings.

#### 03.05.15.02 RELATED WORK

- A. Section 03.05.23 – Boring, Jacking, and Directional Drilling

#### 03.05.15.03 REFERENCES

- A. ACI 523.1R – Guide for Cast-in-Place Low-Density Cellular Concrete
- B. ACI 305R – Hot Weather Concreting
- C. ACI 306R – Cold Weather Concreting

#### 03.05.15.04 SUBMITTALS

- A. Mix Design
  1. The Contractor shall furnish, at his expense, a mix design for the proposed LDCC that will produce the density and minimum compressive strength required.
  2. The mix design shall include laboratory data verifying mix design meets the requirements and product certifications that component materials meet the specified requirements.
- B. Contractor Qualifications
  1. Submit the following information for the Contractor installing the cellular concrete:
    - a. Name of organization and contact information including key personnel, titles, and roles and responsibilities of all persons involved in the manufacturing and installation of cellular concrete.
    - b. Contractor certification as an applicator of cellular concrete and history of successful applications of cellular concrete having a minimum of 500 cubic yards in the past five years.
- C. Quality Control and Placement Plan:
  1. Submit a quality control and placement plan a minimum of 10 days prior to placement of material.
  2. The plan shall include, as a minimum, the following elements:
    - a. The process of communications by which quality control information will be disseminated to the appropriate persons, including material suppliers.
    - b. Proposed construction sequence and schedule.

- c. Type, brand, and model number of specialized cellular concrete production equipment to be used.
- d. Type and brand of cellular concrete production foam concentrate and manufacturer's specifications.
- e. Test plan for assurance of density and compressive strength measurements.

#### 03.05.15.05 QUALITY ASSURANCE

- A. Perform work in accordance with ACI 523.1R
- B. Obtain cement, aggregate, and admixtures from the same source for all work.

#### 03.05.15.06 FIELD QUALITY CONTROL

- A. Contractor is responsible for demonstrating compressive strength of concrete actually used in the completion of the work.
- B. Testing:
  - 1. Provide one slump test for each truck load delivered.
  - 2. Provide one set of cylinders for strength testing for each 100 cubic yards, unless directed otherwise by the Engineer.

#### 03.05.15.07 EQUIPMENT

- A. The equipment used shall have been designed and manufactured specifically for the production of cellular concrete.
- B. The equipment used shall have been designed and manufactured by a manufacturer of cellular concrete equipment whose equipment has been used in the production of at least 50,000 cubic yards of cellular concrete in a variety of conditions over a period of five or more years. If requested, the manufacturer must provide documentation demonstrating such usage.
- C. The manufacturer of the equipment shall have five years or more of experience directly designing, directly producing and providing technical support for cellular concrete production equipment.

### PRODUCTS

#### 03.05.15.08 FOAM CONCENTRATE

- A. Foam concentrate shall be compliant with ASTM C869 and shall have been tested by an independent ASTM recognized testing lab.
- B. The Contractor shall provide a certificate of compliance with ASTM C869, which shall have been issued by the manufacturer of the foam concentrate.



- C. The foam concentrate shall have been used in the production of at least 50,000 cubic yards of cellular concrete in a variety of conditions over a period of five or more years. If requested, the manufacturer must provide documentation demonstrating such usage.

#### 03.05.15.09 CEMENT

- A. Portland Cement shall conform to the requirements of ASTM C150.

#### 03.05.15.10 WATER

- A. Mixing water shall be potable.

#### 03.05.15.11 ADMIXTURES

- A. Water reduction or set accelerating admixtures may be used with some, but not all, foam concentrate in concrete in accordance with the admixture manufacturer's recommendations.
- B. Most polycarboxylate water reducers are formulated with defoamers. Only the minimum amount (rate) required should be used. Testing with the proposed water reducer, before the work is performed, must be done to assure that collapse from foam breakdown before set-up does not occur.

#### 03.05.15.12 MIX DESIGN

- A. Low Density Cellular Concrete shall have a minimum 28-day compressive strength of 100 psi.
- B. If no water is present in the pipeline or casing a low-density grout with a minimum wet density of 30 pounds per cubic foot may be used.
- C. If water is present, a high-density grout, which may include sand, with a minimum wet density of 70 pound per cubic foot shall be used.

### **EXECUTION**

#### 03.05.15.13 SPECIALIZED BATCHING, MIXING, AND PLACING EQUIPMENT

- A. Batching, mixing, and placing equipment shall be capable of producing material that meets the requirements of the section.
- B. Cement and water may be premixed and delivered to the site.
- C. Foam shall be added and mixed at the site using aforementioned equipment.

#### 03.05.15.14 PERSONNEL REQUIREMENTS

- A. One or more members of the Contractor's staff shall have been certified by the manufacturer of the foam concentrate and the foam generation equipment used in the production of the cellular concrete.
- B. The cellular concrete installer shall use adequate numbers of skilled workers who are thoroughly trained and experienced in the necessary crafts and who are familiar with the specified requirements and the methods needed for the proper performance of the work.

#### 03.05.15.15 QUALITY CONTROL AND QUALITY ASSURANCE TESTING

- A. Cast Density
  - 1. During placement of the initial batch, the installer shall check the density and adjust the mix as required to obtain the manufacturer's specified cast density at point of placement.
  - 2. At the point of placement, the density must comply with the specified cast density.
  - 3. A single cast density test must represent the lesser of 100 cy or 2 hours of production.
- B. Compressive Strength
  - 1. The compressive strength shall be tested under ASTM C 495.
  - 2. An alternate testing method may be used as approved by the engineer.
  - 3. Unless otherwise approved, the specimens must be 3-inch x 6-inch cylinders.
  - 4. During molding, place the concrete in two equal layers and lightly tap the side or bottom of the cylinder to close any accidental entrained air.
  - 5. No rodding is allowed.
  - 6. At a minimum, prepare a set of 4 test cylinders for each 400 CY of cellular concrete placed or a minimum of 2 sets of 4 cylinders each per day (whichever is greater).
  - 7. Specimens must be covered and protected immediately after casting to prevent damage and loss of moisture.
  - 8. Specimens should be cured in the molds for up to 7 days and then removed from the mold and moist cured.
  - 9. Stop moist curing specimens from 24 to 72 hours before the 28-day compressive strength test and allow to air dry.
  - 10. Specimens must not be oven dried.

#### 03.05.15.16 MIXING AND PLACEMENT

- A. Concrete shall be mixed and placed in accordance with good concrete practices by an installer with three or more years of experience with concrete density reduction using externally generated foam or shall be approved by the manufacturer of the foam concentrate.

- B. Field density checks shall be made periodically, using the Richway QC Kit or equivalent.
- C. Cellular concrete shall be a homogeneous mix with all materials approved prior to use.
- D. Cellular concrete must be job site mixed with foaming agent and placed with equipment specialized for cellular concrete material. Cement and water may be premixed and delivered to the job site and foaming agent added on site.
- E. Once mixed, the cellular concrete shall be conveyed promptly to the location of placement without excessive handling.
- F. A minimum 12-hour curing period between lifts is required.
- G. If ambient temperatures are anticipated to be below 32°F within 8 hours after cellular concrete placement, mixing water must either be heated as approved by the foaming agent manufacturer or placement must be prohibited.
- H. Cellular concrete must not be placed on frozen ground.
- I. Any material that does not meet the minimum specified strength within 28 days shall be removed and replaced by the Contractor at no additional cost.

#### 03.05.15.17 ACCEPTANCE

- A. The Contractor shall rectify any cellular concrete material rejected by the Engineer that does not meet the minimum required material properties or is not installed in accordance with this specification.
- B. Corrective measures are subject to the approval of the Engineer.
- C. Accepted corrected measures will be performed by the Contractor at no additional cost or extension of the contract time.
- D. This includes removal and replacement of rejected cellular concrete material not meeting the minimum material requirements or installed in accordance with this specification.

#### 03.05.15.18 DEFECTIVE CONCRETE

- A. Defective concrete is defined as concrete in place, which does not conform to the strength, shapes, alignments, appearances and/or elevation, as shown on the drawings and/or presents faulty surface areas.
- B. Concrete surfaces not finished or cured in accordance with specifications are classified as defective concrete.
- C. Defective concrete shall be removed and replaced at no additional cost.

- D. Formed surfaces larger or smaller than the specified dimensional tolerances shall be deemed defective concrete.
- E. If the Project Engineer permits the Contractor to correct the error, such correction shall be as directed and in such a manner as to maintain the strength, function, and appearance of the structure.
- F. Concrete members cast in the wrong location shall be rejected and shall be removed and recast at no additional cost.
- G. Inaccurately formed surfaces exposed to view may be rejected and shall be repaired or removed and replaced and no additional cost.
- H. Concrete exposed to view with defects which adversely affect the appearance of the specified finish shall be repaired.
- I. If the Project Engineer determines the defects cannot be repaired, the concrete shall be deemed defective and rejected.
- J. The strength of the structure in place will be considered defective if it meets any of the following requirements:
  - 1. Actual laboratory strength less than the strength specified.
  - 2. Reinforcing steel size, quantity, strength, position, or arrangement differs from the drawings.
  - 3. Concrete which differs from the required dimensions or locations in such a manner as to reduce the strength of the structure.

## **PRICE AND PAYMENT**

### **03.05.15.19 METHOD OF MEASUREMENT**

- A. Except if specifically called out on the bid schedule, LDCC will normally be incidental to the contract.
- B. If specifically called out on the bid schedule, measurement shall be made in the units shown on the bid schedule to the nearest tenth.

### **03.05.15.20 BASIS OF PAYMENT**

- A. Except if specifically called out on the bid schedule, LDCC will normally be incidental to the contract and no additional payment will be provided for this work.
- B. If specifically called out on the bid schedule, payment shall be made for the actual amount of work performed in the units shown on the bid schedule.
- C. Any payment made shall be full compensation for all materials, labor, equipment, and incidentals necessary to complete the work.

## **END OF SECTION**

## SECTION 03.11.13 – CONCRETE FORMWORK

### GENERAL

#### 03.11.13.01 SUMMARY

- A. This section covers formwork for cast-in-place concrete complete with furnishing, preparation, installation, coating, protection, adjustment, removal, and accessories.

#### 03.11.13.02 RELATED WORK

- A. Section 03.05.13 – Concrete
- B. Section 32.06.10 – Concrete Sidewalk, Handicap Ramps, and/or Detectable/Tactile Warning Surfaces
- C. Section 32.13.13 – Concrete Paving
- D. Section 32.16.13 – Concrete Curb and Gutter

#### 03.11.13.03 REFERENCES

- A. ACI 347 – Guide to Formwork for Concrete

#### 03.11.13.04 SUBMITTALS

- A. Literature on form coating.
- B. Formwork layout plans, design data, and procedures, if requested by Engineer.

#### 03.11.13.05 QUALITY ASSURANCE

- A. Design of loads, lateral pressure, and allowable stresses as outlined in ACI 347.

### PRODUCTS

#### 03.11.13.06 FORM SURFACES

- A. Lumber:
  - 1. Straight, free from knots, offsets, holes, dents, warpage, and other surface defects.
  - 2. Uniform width and thickness.
- B. Plywood:
  - 1. Product standard psi, waterproof, resin bonded.
  - 2. Exterior type Douglas fir.
  - 3. Grade B or better for side adjacent to concrete.

- C. Metal:
  - 1. Smooth metal plate free of surface irregularities.
- D. Chamfer Strips:
  - 1. Clear white pine, 1-inch bevel width.
  - 2. Surface against concrete planed.

#### 03.11.13.07 FORM COATING

- A. Non-staining form oil or other mineral oil that will neither discolor nor otherwise injuriously affect the concrete.

#### 03.11.13.08 FORM TIES

- A. Permanently embedded body type with removable end cones on outer ends.
- B. Permanently embedded portion 1 inch back from concrete face.

### EXECUTION

#### 03.11.13.09 PREPARATION

- A. Do not use forms that show evidence of surface wear and tear or defects that would impair the quality of the surface.
- B. Clean surface of forms and embedded material of any mortar, foreign material, or water before placing coating. Remove surplus coating on form surfaces or any coating on reinforcing steel and construction joints before placing.

#### 03.11.13.10 FIELD QUALITY CONTROL

- A. Tolerance limits for formwork are as follows:
  - 1. Variations from plumb in lines and surfaces of piers, walls, or columns:
    - a. In any 10 feet of length:  $\frac{1}{4}$ -inch.
    - b. Maximum for entire length: 1-inch.
  - 2. Variation from the level or from the grades:
    - a. In any 10 feet of length:  $\frac{1}{4}$ -inch.
    - b. Maximum for entire length:  $\frac{3}{4}$ -inch.
  - 3. Variation of distance between walls, columns, and beams:
    - a. In any 10 feet of length:  $\frac{1}{4}$ -inch.
    - b. Maximum for entire length: 1-inch.
  - 4. Variation of the linear lines as indicated on the plans:
    - a. In any 20 feet of length:  $\frac{1}{2}$ -inch.
    - b. Maximum for entire length: 1-inch.
  - 5. Variation in sizes and locations of sleeves, floor and wall openings:
    - a. Minus  $\frac{1}{4}$ -inch, Plus  $\frac{1}{2}$ -inch.
  - 6. Var. in cross-sec. dim. of columns and beams, and thickness of slabs and walls:
    - a. Minus  $\frac{1}{4}$ -inch, Plus  $\frac{1}{2}$ -inch.

7. Variation of footing dimension:
  - a. In Plan: Minus ¼-inch, Plus 2%.
  - b. Thickness: Minus 5%.

#### 03.11.13.11 INSTALLATION OF FORMS

- A. Set forms true to lines and grades indicated on the plans, tied and braced to remain true, within tolerances, during and after concrete placement.
- B. The Project Engineer may condemn any section or sections of forms found deficient in any respect, and such form shall be promptly removed and replaced.
- C. No wooden spreaders are allowed to remain in the concrete and no metal shall be within 1 inch of any surface.
- D. Prepare forms for keyways in advance of placing concrete.
- E. Keyway forms for horizontal joints in walls may be placed at the conclusion of the concrete placement, provided the full depth and form of the keyway is maintained.
- F. Screw jacks for pipe shores or scaffold type shoring may be used at both top and bottom, so long as they are secured to avoid lateral deflection.
- G. Wedges may be used at the top or bottom of shoring, but not at both ends, to facilitate vertical adjustment, to correct uneven settlements, or to facilitate formwork dismantling.
- H. Check elevations, camber, and plumbness of formwork before initial set and make appropriate adjustments promptly where necessary.

#### 03.11.13.12 REMOVAL OF FORMS

- A. Do not remove forms, wedges, or shoring until concrete has attained a sufficient strength to safely support all loads.
- B. Forms and shoring used to support the weight of concrete in beams, slabs, and other structural members shall remain in place a minimum of 14 days or until the concrete has a min. cylinder strength of 2,500 psi or 2/3 of the specified compressive strength, whichever is greater.
- C. Formwork for columns, walls, and other vertical members shall remain in place for a minimum of 2 days unless the formwork also supports the beams and slabs.
- D. Forms for sidewalks or other non-structural flat work shall remain in place for not less than 12 hours after concrete placement.
- E. Remove forms in an orderly fashion, taking care to not damage the structure, to permit the concrete to carry its share of the loads gradually and uniformly.

### 03.11.13.13 RESHORING

- A. Install re-shores when removing forms before structural members are strong enough to carry dead load and or construction loads to assure a safe distribution.

**END OF SECTION**



## SECTION 31.11.10 – SITE CLEARING

### GENERAL

#### 31.11.10.01 SUMMARY

- A. This section covers clearing, grubbing, removing, and disposing of vegetation and debris within the limits of the right-of-way, borrow and easement areas, except such objects designated to remain or to be removed in accordance with other sections of these specifications. within the proposed areas of construction.

#### 31.11.10.02 RELATED WORK

- A. Section 01.71.23 – Staking and Construction Surveying
- B. Section 31.14.13 – Earthwork
- C. Section 31.23.16 – Excavation, Trenching and Backfill
- D. Section 32.91.19 – Topsoiling, Seeding, Fertilizing, and Mulching

### EXECUTION

#### 31.11.10.03 CLEARING AND GRUBBING

- A. Obtain necessary permit from the Owner prior to cutting any trees or brush (if applicable).
- B. Remove and dispose of all trees, stumps, brush, debris, and all other obstructions as needed to complete construction as specified.
- C. If possible, within right-of-way and property lines, extend clearing and grubbing a minimum of 10 feet beyond all proposed structures unless otherwise directed by the Project Engineer.
- D. Materials, debris, and perishables shall be disposed of at locations outside of the construction area and by methods approved by the Engineer.
- E. The Contractor shall not burn, bury, and/or leave materials in construction areas unless approved by the Project Engineer.
- F. If disposal is by burial on the project site is requested and approved, a cover material of at least 12 inches shall be provided and the area shall be graded and shaped to the satisfaction of Engineer.
- G. If the disposal location is off the project, the Contractor shall make all arrangements with any affected property owners in writing for obtaining suitable disposal locations, which shall be outside the view from the project. All costs shall be incidental to the contract.

- H. Timber which can be utilized for logs, posts, poles, ties, or cordwood, shall be considered as merchantable timber and shall be the property of the Owner or (previous) landowner unless otherwise specified.
- I. Such timber shall, when so noted in the contract, be trimmed and cut into merchantable lengths and neatly piled adjacent to the right-of-way at locations designated by the Engineer.
- J. The Contractor will not be required to cut merchantable timber into lengths shorter than 16 feet.
- K. Low-hanging, unsound, or unsightly branches on remaining trees or shrubs shall be removed as directed.
- L. Branches of trees extending over the roadbed shall be trimmed to provide adequate sight distance for vehicular or pedestrian traffic in accordance with good tree trimming practices.
- M. Except in areas to be excavated, holes resulting from the removal of obstructions shall be backfilled with suitable material and compacted to the satisfaction of the Engineer.
- N. All disturbed areas shall be permanently reclaimed.

## **PRICE AND PAYMENT**

### **31.11.10.04 METHOD OF MEASUREMENT**

- A. Except if specifically called out on the bid schedule, site clearing will normally be incidental to the contract.
- B. If specifically called out on the bid schedule, measurement shall be made in the units shown on the bid schedule to the nearest tenth.

### **31.11.10.05 BASIS OF PAYMENT**

- A. Except if specifically called out on the bid schedule, site clearing will normally be incidental to the contract and no additional payment will be provided for this work.
- B. If specifically called out on the bid schedule, payment shall be made for the actual amount of work performed in the units shown on the bid schedule.
- C. Any payment made shall be full compensation for all materials, labor, equipment, and incidentals necessary to complete the work.

## **END OF SECTION**

## **SECTION 31.14.13 – EARTHWORK**

### **GENERAL**

#### **31.14.13.01 SUMMARY**

- A. This section includes rough and finished site grading of all areas disturbed during construction.

#### **31.14.13.02 RELATED WORK**

- A. Section 01.71.23 – Staking and Construction Surveying
- B. Section 31.11.10 – Site Clearing
- C. Section 31.23.16 – Excavation, Trenching and Backfill
- D. Section 32.91.19 – Topsoiling, Seeding, Fertilizing, and Mulching

### **EXECUTION**

#### **31.14.13.03 ROUGH GRADING**

- A. Grade the area in the vicinity of the excavation to prevent surface water from flowing into the excavation.
- B. Maintain the existing drainage.

#### **31.14.13.04 FINISH GRADING**

- A. Grade site to true grades as specified on the plans after all structures and piping have been installed.
- B. Grade Sites for effective drainage away from structures.
- C. Dress and trim all slopes.

### **PRICE AND PAYMENT**

#### **31.14.13.05 METHOD OF MEASUREMENT**

- A. Except if specifically called out on the bid schedule, earthwork will normally be incidental to the contract.
- B. If specifically called out on the bid schedule, measurement shall be made in the units shown on the bid schedule to the nearest tenth.

#### 31.14.13.06 BASIS OF PAYMENT

- A. Except if specifically called out on the bid schedule, earthwork will normally be incidental to the contract and no additional payment will be provided for this work.
- B. If specifically called out on the bid schedule, payment shall be made for the actual amount of work performed and accepted in the units shown on the bid schedule.
- C. Any payment made shall be full compensation for all materials, labor, equipment, and incidentals necessary to complete the work.

**END OF SECTION**

## **SECTION 31.23.16 – EXCAVATION, TRENCHING AND BACKFILL**

### **GENERAL**

#### **31.23.16.01 SUMMARY**

- A. This section includes excavation, trenching and backfill necessary for the construction of the facilities as indicated on the plans including, but not limited to: water mains and service lines and associated appurtenances, sewer mains and service lines, concrete manholes, storm sewer, streets, and other structures.

#### **31.23.16.02 RELATED WORK**

- A. Section 31.11.10 – Site Clearing
- B. Section 31.14.13 – Earthwork
- C. Section 31.23.19 – Dewatering
- D. Section 32.91.19 – Topsoiling
- E. Section 32.91.21 – Fertilizing
- F. Section 32.92.19 – Seeding
- G. Section 32.92.21 – Mulching
- H. Section 31.23.17 – Rock Excavation
- I. Section 33.11.13 – Potable Water Distribution
- J. Section 33.11.15 – Potable Water Service Lines
- K. Section 33.31.13 – Sanitary Sewer Main
- L. Section 33.31.15 – Sanitary Sewer Service Lines
- M. Section 33.49.13 – Sanitary Sewer Manholes

#### **31.23.16.03 REFERENCES**

- A. Manual on Uniform Traffic Control Devices
- B. ASTM D698 – Test Methods for Moisture Density Relations of Soils and Soil-Aggregate Mixtures Using 5.5 lb. Rammer and 12-in. Drop [Standard Proctor Test]
- C. **ASTM D2321 – Underground Installation of Flexible Thermoplastic Sewer Pipe**
- D. ASTM D2487 – Classification of Soils for Engineering Purposes [Unified Soil Classification System]

31.23.16.04 SUBMITTALS

A. Polystyrene Insulation

31.23.16.05 DEFINITIONS

A. Bedding, Haunching and Initial Backfill zones as defined herein and on the standard pipe trench detailed drawing below. The detail on the right is the updated version to reflect current ASTM D2321 requirements. The final backfill material may extend down to the top of the pipe if the material is less than 1.5 inches (37.5 mm) in size.

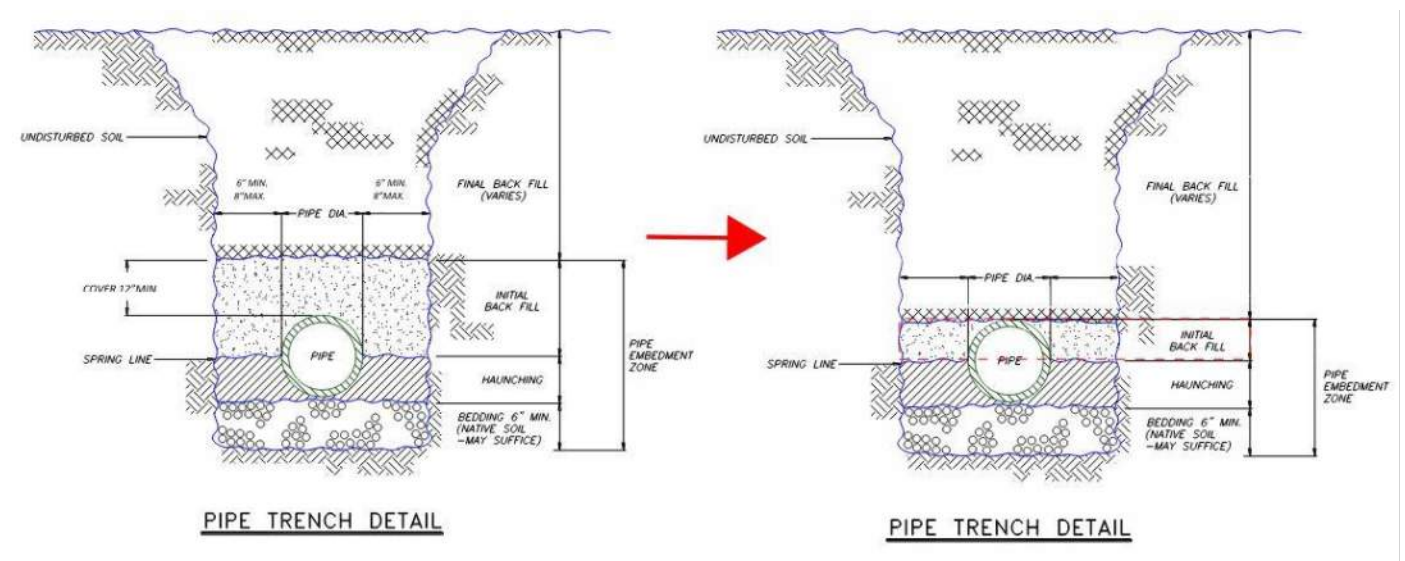

B. Soil Materials as summarized in the *Description and Comparison of Soil Material Classifications* table below and defined in ASTM D2321 and ASTM D2487.

ASTM D2321		ASTM D2487	
Class	Type	USCS Symbol	Description
IA	Manufactured aggregates: ¼ to 1 ½ inch open graded, clean.	* None	Closest to “Poorly graded gravel (GP)”
IB	Manufactured aggregates: ¼ to 1 ½ inch dense graded, clean.	* None	Closest to “Poorly graded gravel with sand (GP)”
II	Coarse sands and gravels with maximum particle size of 1 ½ inch, clean.	GW	Well-graded gravels and gravel-sand mixtures; little or no fines.
		GP	Poorly graded gravels and gravel sand mixtures; little or no fines.
		SW	Well-graded sands and gravelly sands; little or no fines.
		SP	Poorly graded sands and gravelly sands; little or no fines
	Coarse sands and gravels with maximum particle size of 1 ½ inch, borderline clean.	GW-GC SP-SM	Sands and gravels which are borderline between clean and with fines
III	Fine sand and clayey gravels.	GM	Silty gravels, gravel-sand-silt mixtures.
		GC	Clayey gravels, gravel-sand-clay mixtures
		SM	Silty sands, sand-silt mixtures
		SC	Clayey sands, sand-clay mixtures
IV	Fine grain Low plasticity soils (inorganic)	ML	Inorganic silts, very fine sands, rock flour, silty or clayey fine sands, silts with slight plasticity.
		CL	Inorganic clays-low/medium plasticity, gravelly clays, sandy clays, silty clays, lean clays.
V	Fine grain High plasticity soils (organic)	MH	Inorganic silts, micaceous or diatomaceous fine sandy or silty soils, elastic silts.
		CH	Inorganic clays of high plasticity, fat clays.
		OL	Organic silts/silty clays of low plasticity.
		OH	Organic clays of medium to high plasticity, organic silts.
		PT	Peat and other high organic soils.

\* USCS system is limited to naturally occurring soils. Manufactured aggregates not covered.

## PRODUCTS

### 31.23.16.06 BEDDING, HAUNCHING AND INITIAL BACKFILL MATERIAL

- A. Class I, Class II or Class III, utilized in accordance with restrictions described in the EXECUTION part of this specification.

### 31.23.16.07 INSULATION

- A. Rigid extruded polystyrene insulation board, 2 inches thick, having a minimum compressive strength of 25 psi.
- B. Width:
  - 1. 4 feet for mains up to 12-inch (nominal diameter),
  - 2. 3 feet for mains and service lines up to 6-inches (nominal diameter), or as shown in the plans.

## EXECUTION

### 31.23.16.08 GENERAL

- A. Trenching and excavation work shall be done in accordance with proper emphasis on safety as determined by the Contractor to conform to recommended safety standards such as OSHA 1910 and 1926.
- B. A Competent Person, as defined by OSHA 1926, shall be on site at all times when excavation work is being completed.
- C. Provide suitable sheathing, shoring, and bracing as required in conformance with OSHA regulations.
- D. Obtain all permits from appropriate road agency for construction within road right of way.
- E. Repair damage resulting from settlement, slides, cave-ins, water pressure, and other causes.
- F. Provide adequate signs, barricades, fences and amber lights and take all necessary precautions to protect the work and the safety of the public in all construction areas.
  - 1. Placement of construction signs and barricades shall conform to the “Manual on Uniform Traffic Control Devices.”
  - 2. Protect barricades and obstructions at night by amber signal lights that burn from sunset to sunrise. Barricades shall also be of substantial construction, painted white or with reflective paint to increase their visibility at night.
  - 3. Perform work without obstruction to traffic or inconvenience to the general public and the residents in the vicinity of the work.



G. The maximum open trench allowed at each location shall not exceed 200 feet.

H. Road Crossing

1. Comply with all construction and material requirements of roadway authorities having jurisdiction.
2. Always keep one lane of traffic open.
3. Any service line must be sleeved or cased when bored UNDER roadways.

31.23.16.09 EXCAVATION

- A. Remove trees and stumps from excavation and site.
- B. Remove and stockpile existing topsoil.
- C. Install facilities as staked unless otherwise approved by Project Engineer.
- D. Maintain surface drainage away from trenching or excavation.
- E. Remove unsuitable foundation materials from excavation as shown on the plans or as authorized by the Project Engineer.
- F. Maintain a minimum 1-foot clearance between outer surface of structure being installed and wall of excavation.
- G. Rock encountered shall be classified, excavated, and measured in accordance with Section 31.23.17.

31.23.16.10 TRENCHING

- A. Bottom width:
  1. No less than 12 inches or more than 24 inches wider than the outside diameter of the pipe.
  2. Where a chain or wheel trencher is approved for use in a rural area, the trench width shall be 4 to 6 inches greater than the outside diameter of the pipe.
- B. Depth: Provide minimum cover as specified, or depths shown on plans.

31.23.16.11 BEDDING

- A. If existing soil cannot provide uniform, stable bearing support, over-excavate 6 inches below bottom of pipe or structure and provide bedding material.
- B. Unauthorized over excavation shall be backfilled with acceptable bedding material.
- C. Utilize Class I, II or III materials as appropriate for bedding as listed in Table below.



*Use of Soils and Aggregate for Bedding*

	<i>Class IA</i>	<i>Class IB</i>	<i>Class II</i>	<i>Class III</i>	<i>Class IV</i>
General	Excellent pipe support. Excellent drainage.	Excellent pipe support. Good drainage. Minimizes migration of adjacent material.	Good pipe support. Fair drainage.	Reasonable pipe support. Poor drainage	Poor pipe support. Poor drainage
Compaction	Not required	Not required	Required 90% of Standard Proctor.	Required 95% of Standard Proctor.	Required 95% of Standard Proctor.
Wet Conditions (below current or future water table). Rock Cuts	Acceptable. Must use same material for Haunching.	Acceptable. Must use same material for Haunching.	Acceptable. Clean groups only suitable for drainage blanket.	Not-Acceptable	Not-Acceptable
Dry Conditions	Acceptable	Acceptable	Acceptable	Acceptable	Acceptable

31.23.16.12 HAUNCHING AND INITIAL BACKFILL

A. General.

1. Provide complete and uniform bearing and support for the pipe, including allowance for bell holes, or structure.
2. Work material under and around the pipe to ensure full pipe support.
3. Prevent movement of the pipe during placement of material.
4. Avoid contact between the pipe and mechanical compaction equipment.
5. Where a trencher is approved, backfill the trench from surface with selected material, free from large clods and all stones larger than 3 inches.

B. Utilize Class I, II, III, or IV materials as appropriate for haunching and initial backfill as listed in Table below. No frozen materials or frozen clods.

*Use of Soils and Aggregate for Haunching and Initial Backfill*

	<i>Class IA</i>	<i>Class IB</i>	<i>Class II</i>	<i>Class III</i>	<i>Class IV</i>
General	Excellent pipe support. Excellent drainage. Install to a min. of 6" above pipe crown or to top of pipe if final backfill material is less than 1.5 inches in size.	Ex. pipe support. Good drainage. Minimizes migration of adjacent mat. Install to 6" min. above pipe crown or to top of pipe if final backfill material is less than 1.5 inches in size.	Good pipe support. Fair drainage. Install and compact to a min. of 6" above the pipe crown or to top of pipe if final backfill material is less than 1.5 inches in size.	Reasonable pipe support. Poor drainage. Install & compact to 6" min. above pipe or to top of pipe if final backfill material is less than 1.5 inches in size.	Poor pipe support. Poor drainage. Install and compact to 6" min. above the pipe crown or to top of pipe if final backfill material is less than 1.5 inches in size.
Compaction	Not required	Not required	Required 85% Std Proctor - 6" max. lifts.	Required 90% of Std Proctor - 6" max. lifts.	Required 95% of Std Proctor - 6" max. lifts.
Wet Conditions (below water table). Rock Cuts	Acceptable. Use also for bedding. Ext. haunching to crown of pipe.	Acceptable. Use same mat. for bedding. Ext. haunching to pipe crown.	Acceptable. Clean groups only suitable for drainage.	Not-Acceptable	Not-Acceptable
Dry Conditions	Acceptable	Acceptable	Acceptable	Acceptable	Acceptable

**31.23.16.13 FINAL BACKFILL**

- A. Backfill remainder of excavation with native material, free from large clods, stones 8 inches or larger, organic material or frost chunks.
- B. Compact in 12-inch lifts to a density not less than the density of the surrounding undisturbed soil.
  - 1. Provide 3 feet minimum of backfill over the pipe before wheel loading the trench.
  - 2. Provide 4 feet minimum cover over the top of the pipe before utilization of hydrohammer compaction equipment.
- C. Compact backfill under roadways in 12-inch lifts.
  - 1. Compact with mechanical tamper to a density not less than 90% of the maximum dry density, determined by ASTM D698 for the top 3 feet of the trench through a roadway or driveway.
- D. Backfill and compact around manholes, valve boxes, and other appurtenances in 12-inch lifts.

1. Compact with a mechanical tamper to a density not less than 90% of the maximum dry density, determined by ASTM D698.
- E. Repair any trenches improperly backfilled or where settlement occurs, then refill and compact.
- F. Restore surface to the required grade and compaction. Conform to Section 31.14.13 for rough grading, finish grading and site surface drainage.
- G. Remove all surplus backfill materials to a location approved by the Project Engineer.

#### 31.23.16.14 FROST PROTECTION

- A. Place insulation in areas where water main, sewer service lines or water service lines cross a road, driveway, traveled path, storm sewer inlet boxes where coverage is less than 6 feet from bottom of box to top of pipe or as indicated on the plans.
- B. Center insulation over pipe or appurtenance with 1 foot of compacted fill between the pipe and the insulation. Grade fill so insulation lays flat.
- C. Insulate with a minimum of one 2 inch layer of polystyrene.
  1. If a minimum bury depth is specified, install one 2-inch-thick layer for each foot of backfill less than the required minimum bury depth.
- H. Extend insulation a minimum of 5 feet on each side of the crossing.
- I. Lap insulation by 6 inches or stagger by 6 inches if composed of two layers.
- J. The minimum thickness for the first lift of backfill over the insulation is 8 inches.
  1. Do not operate construction equipment directly on insulation. Do not compact the first lift with backhoe-mounted compactor or any other large compaction equipment.
  2. Compact remaining backfill using normal construction practices.

#### 31.23.16.15 REMOVAL OF NUISANCE WATER

- A. Remove nuisance water entering the trenches. Nuisance water that can be removed with sump or trash pumps is not considered dewatering.
- B. Keep trenches free from water until the facilities are in place, sealed against the entrance of water, and backfill has been placed and compacted above the water level.

#### 31.23.16.16 LOCATE EXISTING UTILITIES

- A. Field locate all existing underground utilities.
  1. Utilize state “dig-safe” or “one-call” hotlines.
  2. Contact all other utility owners not covered by the state “dig safe” hotlines.

### 31.23.16.17 UTILITY CONFLICTS

- A. Protect existing utilities from damage during excavation and backfilling operations.
- B. Provide temporary support for existing water, gas, telephone, power, or other utility services that cross the trench until backfilling of trench is complete:
  - 1. Compact backfill to 95% of Standard Proctor Density under disturbed utilities.
  - 2. Repair or replace any damaged existing utilities, at no additional cost to the project.
- C. Water and sewer main crossing and parallel installation
  - 1. Maintain a 10-foot horizontal separation (O.D. to O.D.) for parallel mains.
  - 2. Upon approval by the Project Engineer, water and sewer mains may be installed closer than 10 feet, provided all the following conditions:
    - a. Vertical separation is 18 inches (O.D. to O.D.)
    - b. Water main is above the sewer main.
    - c. Separate trenches are maintained.
  - 3. Maintain a minimum 18-inch vertical separation (O.D. to O.D.) for crossing mains with the water main above the sewer main.
    - a. Lay pipe with joints equidistant from the point of crossing.
  - 4. If it is impossible to meet any of the above separation distances and deviations, one of the following methods shall be adhered to.
    - a. Sewer main shall be constructed to water main pressure pipe standards, and successfully pass a 150-psi pressure test prior to backfilling.
    - b. Either the water main or the sewer main may be encased in a watertight carrier pipe that extends 10 feet on both sides of the crossing.
    - c. The carrier pipe shall be of materials approved by the regulatory agency for use in water main construction.
- D. Water and sewer service crossing and parallel installation.
  - 1. Maintain a 30-inch horizontal separation from water and sewer services.
  - 2. Maintain a 12-inch vertical separation for crossing water and sewer services.
- E. Water service line splices or joints will not be permitted within 10 feet of a sewer line crossing.

#### 31.23.16.18 MOVING FENCES AND MINOR STRUCTURES

- A. Remove and reset culverts, drainage pipes or other minor structures that fall within the alignment of the new construction, to their original location and grade.
- B. Visit the project site and determine actual conditions with regard to the existence of old car bodies, abandoned houses, fences, driveways, trees, stumps, brush, sidewalks, approaches, and other miscellaneous obstacles to construction.
  - 1. Unless specifically referenced in a bid item, no separate payment will be made for the removal or replacement of these items.

#### 31.23.16.19 RECORDS

- A. Conform to as-built requirements in Section 01.74.13.

### **PRICE AND PAYMENT**

#### 31.23.16.20 METHOD OF MEASUREMENT

- A. Except if specifically called out on the bid schedule, excavation, trenching, and backfill will normally be incidental to the contract.
- B. If specifically called out on the bid schedule, measurement shall be made in the units shown on the bid schedule to the nearest tenth.

#### 31.23.16.21 BASIS OF PAYMENT

- A. Except if specifically called out on the bid schedule, excavation, trenching, and backfill will normally be incidental to the contract and no additional payment will be provided for this work.
- B. If specifically called out on the bid schedule, payment shall be made for the actual amount of work performed in the units shown on the bid schedule.
- C. Any payment made shall be full compensation for all materials, labor, equipment, and incidentals necessary to complete the work.

### **END OF SECTION**

## SECTION 31.23.17 – ROCK EXCAVATION

### GENERAL

#### 31.23.17.01 SUMMARY

- A. This section covers rock excavation necessary during construction.

#### 31.23.17.02 RELATED WORK

- A. Section 33.23.16 – Excavation, Trenching and Backfill

#### 31.23.17.03 REFERENCES

- A. US Department of Labor, Occupational Safety and Health Administration Standard 1910.109 – Explosives and Blasting Agents

#### 31.23.17.04 SUBMITTALS

- A. Contractor's blasting license and/or blasting permit.
- B. Bedding material.

#### 31.23.17.05 DEFINITIONS

- A. Solid Rock:
  - 1. Large masses of igneous, metamorphic, or sedimentary rock which, in the judgment of the Project Engineer, cannot be excavated without drilling, blasting, ripping equipment, or other specialized equipment not normally on the job site.
- B. Loose Rock:
  - 1. Individual boulders and other detached stones having a volume of 1 cubic yard or more.

#### 31.23.17.06 QUALITY ASSURANCE

- A. The materials and construction methods specified herein are minimum requirements. Where the appropriate state/local require more stringent materials or execution methods, they shall apply.
- B. Notify the Project Engineer of any planned deviation from these specifications before proceeding so any price changes or quantity adjustments may be made.



## PRODUCTS

### 31.23.17.07 BEDDING MATERIAL

- A. Sand, gravel, or crushed rock passing a  $\frac{3}{4}$  inch mesh screen.

## EXECUTION

### 31.23.17.08 ROCK MEASUREMENT

- A. Solid rock.
  - 1. Unit of measure is cubic yards.
  - 2. Measure from top of rock to a point 6 inches below the invert of the pipe (or appurtenance) and 12 inches from each side of the pipe (or appurtenance).
- B. Loose rock.
  - 1. Unit of measure is cubic yards.
  - 2. Measurement includes only those rocks or boulders that are individually 1 cubic yard or more in volume.

### 31.23.17.09 EXCAVATION

- A. Solid rock.
  - 1. Excavate to a depth of at least 6 inches deeper than the pipe (or appurtenance) invert.
    - a. A maximum 30-inch trench width is allowed.
  - 2. Refill to the required elevation with bedding material.
    - a. Bedding material shall extend upward at least one half the diameter of the pipe (or appurtenance).
- B. Loose rock.
  - 1. Excavate to provide 6 inches of clear space around pipe (or appurtenance).
  - 2. Refill to the required elevation with bedding material.
    - a. Bedding material shall extend upward at least one half the diameter of the pipe (or appurtenance).
- C. All rock which cannot be handled and compacted as earth shall be kept separate from other excavated materials and shall not be mixed with other backfill materials, except as approved by the Project Engineer.
- D. Dispose of all rock excavated.

### 31.23.17.10 BLASTING

- A. The Contractor is responsible for damage and injury caused by blasting operations.
- B. Comply with all laws, ordinances, applicable safety code requirements and regulations relative to the storage and use of explosives, and the protection of life and property.

- C. No blasting shall be done within 40 feet of finished pipelines.
- D. The open end of finished pipelines shall be closed and covered to a depth of 1 foot or greater before each blast.
- E. Blasts shall be covered with suitably weighted plank coverings or mattresses to confine all materials lifted by blasting.
- F. Erect suitable barricades and/or warning signs on all public thoroughfares leading to the site of blasting operations.
- G. Give adequate audible warning before each blast.

#### 31.23.17.11 BACKFILLING

- A. Refer to Section 00231.

#### 31.23.17.12 AS-BUILTS

- A. Provide as-built information on each system in accordance with Section 00178.

### **PRICE AND PAYMENT**

#### 31.23.17.13 GENERAL

- A. Inclusion of a bid item and estimated quantity for rock excavation in the bid schedule indicates that rock excavation is probable.
- B. The exclusion of rock excavation from the bid schedule does not preclude the possibility that rock will be encountered; it indicates that rock excavation is not anticipated.
- C. If unanticipated rock is encountered a price for rock excavation will be negotiated with the Contractor by the Contracting Officer.

#### 31.23.17.14 EXCAVATED ROCK

- A. Measurement: By the cubic yard, as measured in place.
- B. Basis of Payment: Includes rock excavation, bedding materials, rock disposal, and all other materials and labor to complete the work as specified.

### **END OF SECTION**

## SECTION 31.23.19 – DEWATERING

### GENERAL

#### 31.23.19.01 SUMMARY

- A. This section includes methods, procedures and equipment required for lowering of the ground water table in order to install, repair, or inspect the facilities as shown on the plans or as directed by the Engineer.
- B. Dewatering is defined as the removal of water from a job site by pumps, wellpoints, or drainage systems.
- C. This specification does not include nuisance dewatering as defined in Section 31.23.16.

#### 31.23.19.02 RELATED WORK

- A. Section 31.23.16 – Excavation, Trenching and Backfill

#### 31.23.19.03 SUBMITTALS

- A. Dewatering Plan including piping plan and water release locations.
- B. Schedule for installation, operation, and removal of equipment.
- C. Copies of any Permits required for discharge of groundwater.

#### 31.23.19.04 QUALITY ASSURANCE

- A. Design of Dewatering System:
  - 1. Contractor is responsible for the complete design of all structures and methods proposed for dewatering system.
  - 2. Control discharge rate and effects of dewatering system.
  - 3. Protect adjacent facilities from effects of dewatering.
  - 4. Repair or replace adjacent buildings, structures, or facilities damaged due to dewatering operations.
- B. Temporary Erosion and Sediment Controls: Comply with Storm Water Pollution Prevention Plan for all activities connected with the dewatering.

### EXECUTION

#### 31.23.19.05 PREPARATION

- A. Verify the location, extent and quantity of water that must be removed from the project area.

- B. Request determination from the Project Engineer whether water in the project area is nuisance water or substantial, requiring dewatering operations.
  - 1. Removal of nuisance water is not considered dewatering and shall be performed by the Contractor at no additional expense. Refer to Section 00231.
  - 2. Dewatering conducted without approval from the Project Engineer will be at Contractor's expense.
- C. Verify location of all existing underground utilities and structures that may pose a conflict to the dewatering well points and equipment. Repair any damage to existing utilities and structures at the Contractor's expense.
- D. Coordinate dewatering plan with state/local agency to determine acceptable water release locations and acceptable release volumes.
- E. Secure any and all necessary permits.

#### 31.23.19.06 PERFORMANCE

- A. Drainage system design, operation, and discharge shall not cause any damage to adjacent property.
- B. Maintain the excavation free of water during progression of the work.
- C. Upon completion of dewatering operation, abandon well holes and clean site in accordance with state and local regulations.

### **PRICE AND PAYMENT**

#### 31.23.19.07 DEWATERING 1

- A. Measurement: By the lineal foot of trench dewatered.
- B. Basis of Payment: Includes well points, pumping, piping, and all other appurtenances required to complete the work as specified.

#### 31.23.19.08 DEWATERING 2

- A. Measurement: By the lump sum.
- B. Basis of Payment: Includes well points, pumping, pipe, and all other appurtenances required to complete the work as specified.

**END OF SECTION**

## SECTION 32.01.13 – STREET CRACK SEALING

### GENERAL

#### 32.01.13.01 SUMMARY

- A. This section covers the proposed routing and sealing of transverse and longitudinal cracks in asphalt concrete roadway surfaces.

#### 32.01.13.02 RELATED WORK

- A. Section 32.12.16 – Asphaltic Paving
- B. Section 32.13.13 – Concrete Paving

#### 32.01.13.03 REFERENCES

- A. South Dakota Department of Transportation (SDDOT) Standard Specifications for Roads and Bridges (most recent edition). Applicable section(s) will include Asphalt Concrete Crack Sealing.
- B. Manual on Uniform Traffic Control Devices (MUTCD)

#### 32.01.13.04 SUBMITTALS

- A. Sealant.
- B. Equipment and Process.
- C. Schedule.

#### 32.01.13.05 QUALITY ASSURANCE

- A. The owner reserves the right to have the contractor test routing, cleaning, and/or sealing efforts for compliance these specifications.

### PRODUCTS

#### 32.01.13.06 PRODUCTS

- A. SEALANT
  1. The sealant shall conform to the requirements of ASTM D6690 Type IV.
  2. The sealant material shall not weigh more than 9.35 pounds per gallon.
  3. The blocking medium shall be an inert, compressible material which is compatible with the sealant.

## EXECUTION

### 32.01.13.07 GENERAL

- A. Only one-half of the roadway shall be worked on at a time unless a traffic control plan to work full width is submitted by the Contractor and approved by the Engineer.
- B. Routing and crack sealing shall be considered as one work zone.
- C. A work zone shall not exceed 2 miles in length at any one time.

### 32.01.13.08 ROUTING

- A. Routing equipment shall be mechanical, power driven, and capable of cutting a reservoir to the required dimensions. Equipment designed to plow the cracks to dimension will not be permitted.
- B. Cracks which are less than  $\frac{3}{4}$ -inch in width or depth will require routing to a width and depth of  $\frac{3}{4}$ - to  $\frac{7}{8}$ -inch.
- C. Cracks which are  $\frac{3}{4}$ -inch or greater in width and depth will not require routing but shall be thoroughly cleaned of foreign material to a depth equal to the width of the crack.
- D. The walls of the finished reservoir shall be vertical and the reservoir bottom shall be flat.
- E. Routing will not be allowed when the roadway is wet.

### 32.01.13.09 CLEANING

- A. Cleaning shall be accomplished with an air compressor producing a minimum of 125 cubic feet per minute output and equipped with a maximum  $\frac{3}{4}$ -inch nozzle. The air compressors shall be equipped with traps capable of removing all free water and oil from the compressed air.
- B. Reservoirs and cracks shall be thoroughly cleaned of dust, dirt, and loose materials so the reservoir is clean and dry at the time the blocking medium or sealant is applied.
- C. If a routed reservoir or crack is left overnight, the reservoir shall be re-cleaned immediately before the blocking medium or sealant is applied.
- D. The routed asphalt concrete and foreign material resulting from the reservoir preparation shall be removed from the roadway surface before an area is opened to traffic.

### 32.01.13.10 SEALING

- A. Cracks  $\frac{3}{8}$  inches or greater in width, which exist below the routed and cleaned reservoir, shall be filled with a blocking medium to ensure a nominal sealant depth equal to the width of the reservoir.
- B. Sealant material shall be placed within 72 hours of routing.

- C. There shall be no visible signs of moisture on the roadway surface or in the reservoir at the time the sealant is applied.
- D. The sealant handling, mixing, and application temperature restrictions shall conform to the manufacturer's recommendations.
- E. Sealant shall be applied with a pressure type applicator.
- F. When applying the sealant on all transverse cracks and any longitudinal cracks that are located more than 12 inches from a lane line, the reservoir shall be overfilled and squeegeed to provide a film of sealant on the roadway surface 1- to 2- inches on both sides of the reservoir. When applying the sealant on longitudinal cracks that are located within 12 inches of a lane line, the reservoir shall be overfilled and squeegeed to provide a film of sealant on the roadway surface up to 1-inch on both sides of the reservoir.
- G. The squeegee shall be a "U" shaped device which will produce a full, uniform, and neat appearing reservoir and adjoining surface area. Other type devices will require prior approval by the Engineer.
- H. A blotting material, such as toilet tissue, or an approved de-tacking agent shall be placed over the sealant material immediately after placement at intersections, superelevated curves, urban areas, grades steeper than 4%, and other locations specified on the plans. Blotting material or an approved de-tacking agent will be required when traffic is allowed to cross a sealed area before tack-free status has been achieved.
- I. The Contractor shall repair or refill, at the Contractor's expense, any part of a sealed reservoir damaged by traffic.

#### 32.01.13.11 SEASONAL AND TEMPERATURE LIMITATIONS

- A. Routing and sealing operations will be permitted only during daylight hours between April 1 and June 30 (inclusive) and August 15 and November 30 (inclusive).
- B. Application of the sealant material will only be allowed when the pavement surface temperature is at least 35°F and rising.
- C. Application of the sealant material will only be allowed when the ambient air temperature is between 40°F and 85°F.
- D. Application of sealant material shall be done when relative humidity is less than 75%.

### PRICE AND PAYMENT

#### 32.01.13.12 METHOD OF MEASUREMENT

- A. Asphalt concrete crack sealing will be measured by the foot of crack sealed based on the size of the crack ( $<3/4"$  and  $\geq 3/4"$ ).

### 32.01.13.13 BASIS OF PAYMENT

- A. Asphalt concrete crack sealing will be paid at the contract unit price per verified lineal foot and shall be full compensation for routing, cleaning, and for furnishing, heating, placing, and blotting the sealant. Blocking medium and traffic control shall be incidental to the asphalt concrete crack sealing.

**END OF SECTION**



## SECTION 32.01.14 – ASPHALT STREET CHIP SEALING

### GENERAL

#### 32.01.14.01 SUMMARY

- A. Asphalt street chip sealing work shall consist of any repair of various sections of the roadway, see statement of work and plans for location map, if applicable, followed by preparation of the roadway surface by sweeping prior to the placement of the asphalt surface treatment, cover aggregate, seal coat, and roadway restriping.
- B. Contractor will also be required to provide all necessary traffic control and roadway user notifications required herein.

#### 32.01.14.02 RELATED WORK

- A. Section 32.12.16 – Asphaltic Paving
- B. Section 32.17.23 – Pavement Marking

#### 32.01.14.03 REFERENCES

- A. South Dakota Department of Transportation (SDDOT) Standard Specifications for Roads and Bridges (most recent edition). Applicable section(s) will include Asphalt Surface Treatment, Aggregates for Asphalt Surface Treatments, and Asphalt Material.
- B. Manual on Uniform Traffic Control Devices (MUTCD).

#### 32.01.14.04 SUBMITTALS

- A. Asphalt Surface Treatment.
- B. Cover Aggregate.
- C. Fog Seal.
- D. Equipment and Processes.
- E. Traffic Control Plan.
- F. Schedule.

#### 32.01.14.05 QUALITY ASSURANCE

- A. The owner reserves the right to have the pavement markings tested in accordance with standard SD DOT testing methods.

## PRODUCTS

### 32.01.14.06 PRODUCTS

- A. Asphalt Surface Treatment
  - 1. The Asphalt Surface Treatment shall be CRS-2P emulsified asphalt per the Asphalt Material section of the SDDOT Standard Specifications for Roads and Bridges.
- B. Cover Aggregate
  - 1. Cover aggregate shall meet the requirement of Type 2A aggregate per the Aggregates for Asphalt Surface Treatments section of the SDDOT Standard Specifications for Roads and Bridges with 0-1.5% passing the #200 sieve.
- C. Seal Coat
  - 1. The seal coat shall be SS-1h or CSS-1h emulsified asphalt per the Asphalt Material section of the SDDOT Standard Specifications for Roads and Bridges.

## EXECUTION

### 32.01.14.07 GENERAL

- A. At least one lane of traffic flow shall be maintained during execution of the contract.
- B. All traffic control will be performed in accordance with the MUTCD.
- C. A traffic control plan will be submitted to the Engineer at least one week prior to commencement of work.
- D. The Contractor shall be responsible for notification of impacted residents at least 48 hours prior to work commencing which will impact them. The method and exact message shall be approved by the Engineer prior to notification.

### 32.01.14.08 ASPHALT SURFACE TREATMENT

- A. The asphalt surface treatment shall be CRS-2P emulsified asphalt with an application rate of 0.30 gallons per square yard. The asphalt shall be installed per the SDDOT Standard Specifications for Roads and Bridges using approved equipment.
- B. Aggregate shall be placed at an application rate of 25 pounds per square yard. Immediately after aggregate placement rolling shall commence in accordance with the SDDOT Standard Specifications for Roads and Bridges.

### 32.01.14.09 SEAL COAT

- A. Prior to placement of the seal coat the entire treated surface shall be broomed from the center outward to the edge of the shoulder.
- B. The excess material shall be broomed onto the roadway inslopes with no windrow of cover aggregate left along the edge of the pavement. The brooming operation shall be considered incidental to the seal coat application.

- C. The seal coat shall be applied at a rate of 0.05 gallons per square yard in accordance with the SDDOT Standard Specifications for Roads and Bridges.
- D. The oil will be blended with water to create a ½ water and ½ oil solution applied at 0.10 gallons per square yard. There will be no separate payment for water.
- E. The seal coat shall be placed between 48 hours and 5 calendar days after the surface treatment is placed.

#### 32.01.14.10 TRAFFIC CONTROL

- A. Traffic control shall be maintained during the application of the surface treatment per the SD DOT standard specifications.
- B. At a minimum two electronic notification signs shall be installed at least one week before work is to commence, at each end of the work zone, to notify the traveling public of the upcoming work, recommendations to take alternate routes and warning of potential vehicle damage.
- C. The message run on the electronic notification signs shall be approved by the Owner at least one week prior to the installation of the signs.
- D. Where work is being performed on two-lane streets, flaggers will be required at each end of the work during application processes to ensure one lane of traffic flow is maintained at all times.
- E. Temporary speed limits signs will be required for the surface treatment area with a maximum speed limit of 20 mph from the time the surface treatment placement starts until the seal coat is placed.

### PRICE AND PAYMENT

#### 32.01.14.11 METHOD OF MEASUREMENT

- A. MATERIALS
  - 1. Asphalt for the asphalt surface treatment material, cover aggregate, and seal coat will all be measured to the nearest 0.1 tons.
- B. TRAFFIC CONTROL
  - 1. If traffic control is included on the bid schedule, it shall be measured as a unit lump sum item for the entire project which shall include all items detailed in the “Traffic Control” section above and paid at the Lump Sum price bid for Traffic Control. If traffic control is not included on the bid schedule it shall be considered incidental to the contract.

#### 32.01.14.12 BASIS OF PAYMENT

##### A. GENERAL

1. Payment for the materials will be at the contract unit price bid per ton based upon actual weight tickets.
2. All payments shall be full compensation for all equipment, labor, materials, and incidental work necessary to perform the work in accordance with the project specifications.

**END OF SECTION**

**SECTION 32.06.10 – CONCRETE SIDEWALK, HANDICAP RAMPS, AND/OR  
DETECTABLE/TACTILE WARNING SURFACES**

**GENERAL**

32.06.10.01 SUMMARY

- A. This section includes the construction of sidewalks, handicap access ramps, and/or detectable tactile warning surfaces.

32.06.10.02 RELATED WORK

- A. Section 03.05.13 – Concrete
- B. Section 03.11.13 – Concrete Formwork
- C. Section 32.16.13 – Concrete Curb and Gutter
- D. Section 32.91.19 – Topsoiling, Seeding, Fertilizing, and Mulching

32.06.10.03 SUBMITTALS

- A. Concrete Mix.
- B. Detectable / Tactile Warning Surfaces.

**PRODUCTS**

32.06.10.04 CUSHION MATERIAL

- A. Cushion material shall consist of quarry, rock, gravel or sand, crushed or screened to eliminate material retained on a  $\frac{3}{4}$ -inch sieve. The material shall also be free from roots, sod, lumps of dirt, and other deleterious material. Not more than 25% by weight shall pass a No. 200 sieve.

32.06.10.05 CONCRETE

- A. Concrete for sidewalk shall conform to the requirements of Section 03.05.13 for Class M6 concrete.
- B. Concrete for exposed aggregate sidewalk shall meet the general requirements of Section 03.05.13 for Class M6 concrete except that the large aggregate shall be clean, rounded river rock.
- C. Expansion joint filler shall conform to the requirements of Section 03.05.15.

- D. Curing compound shall conform to the requirements of Section 03.05.13, except that for exposed aggregate sidewalk, normal curing compound shall be deleted, and the exposed aggregate surface shall be protected with an approved mineral solvent or petrochemical solvent based, clear, high gloss acrylic concrete sealer.
- E. Concrete joint sealer shall conform to the requirements of Section 03.05.13.
- F. Concrete reinforcing steel shall conform to the requirements of Section 03.05.13.

#### 32.06.10.06 DETECTABLE / TACTILE WARNING SURFACES

- A. Detectable/Tactile Warning Surfaces shall be Vitriified Polymer Composite (VPC) Cast-in-Place Detectable/Tactile Warning Surface Tile, Armor Tile as manufactured by Engineering Plastics, Inc., ADA Solutions, or approved equal.
- B. The color shall be yellow conforming to Federal Color No. 33538 and be homogeneous throughout the tile.

### EXECUTION

#### 32.06.10.07 FOUNDATION

- A. Sterilize the natural ground area which will be under the new compacted fill with an approved herbicide at least one week prior to beginning fill operations.
- B. The foundation shall be excavated, shaped, and compacted to a firm, uniform, bearing surface conforming to the planned section and established grade.
- C. Unsuitable foundation material shall be removed and replaced as directed.
- D. The foundation shall be thoroughly moistened immediately prior to the placing of concrete.
- E. Cushion material shall be placed under the sidewalk to a minimum depth of 2 inches and satisfactorily compacted.

#### 32.06.10.08 FORMS

- A. Forms shall comply with Section 03.11.13.

#### 32.06.10.09 JOINTS

- A. Joints shall be formed at intervals equal to sidewalk width by means of a grooving tool, to a depth of at least  $\frac{1}{4}$  the thickness of the sidewalk.
- B. Joints and edges shall be finished with an approved edging tool.
- C. Expansion joints with bituminous sealant shall be constructed:

1. at the rate of one joint per 100 foot of length,
2. at the locations and of the dimensions shown on the plans, or
3. as directed by the Engineer.

#### 32.06.10.10 FINISHING

- A. Immediately after the water sheen has disappeared, the concrete shall be brushed or broomed in a direction perpendicular to the flow of traffic to roughen the surface and remove tool marks.
- B. Handicapped access ramps shall receive a medium tined texture in addition to the broomed finish (perpendicular to the slope).

#### 32.06.10.11 COMPLETION

- A. Concrete sidewalk shall be protected and cured in accordance with Section 03.05.13.
- B. After the curing period, the area adjacent to new sidewalk shall be filled to the required elevation with suitable material and the material shall be satisfactorily compacted, seeded, or sodded in accordance with Section 32.91.19.
- C. Colored or stamped concrete or similar forms of architectural concrete finish shall not be placed with in the street right of way, except as specified by the Engineer.

#### 32.06.10.12 TESTING

- A. The Contractor shall be responsible for providing a minimum of one set of slump, air content, 7- and 28-day compressive strength quality tests for each day's pour. Additional test sets or testing may be required by the Engineer.

#### 32.06.10.13 DETECTABLE/TACTILE WARNING SURFACE

- A. Installation of detectable/tactile warning surfaces shall be per manufacturer's installation instructions.

### **PRICE AND PAYMENT**

#### 32.06.10.14 METHOD OF MEASUREMENT

- A. Concrete
  1. Concrete sidewalk and handicap access ramp will be measured to the nearest one-tenth (0.1) linear foot and the area computed to the nearest square foot.
- B. Detectable/Tactile Warning Surfaces
  1. Detectable/tactile warning surfaces will be measured and paid to the nearest square foot furnished and installed.

### 32.06.10.15 BASIS OF PAYMENT

#### A. General

1. Payment for all items will constitute full compensation for labor, equipment, tools, backfilling, furnishing, preparing, testing, and placing materials and incidentals necessary, including disposal of excavation and discarded materials.

#### B. Concrete

1. Concrete sidewalk and handicap access ramp will be paid for at the contract unit price per square foot for concrete sidewalk or handicap access ramp.
2. Such payment shall include cushion material.

#### C. Detectable/Tactile Warning Surface

1. Detectable/tactile warning surface will be paid for at the contract unit price per square foot.

**END OF SECTION**



## SECTION 32.11.23 – GRAVEL (RE)SURFACING

### GENERAL

#### 32.11.23.01 SUMMARY

- A. This work consists of providing one or more courses of aggregate on a prepared surface.
- B. For gravel resurfacing:
  - 1. Scarifying the top four (4") inches of the existing gravel driving surface.
  - 2. Place and compact approved crushed aggregate base course to construct the proposed finished section.
  - 3. Place approved dust control product within the top (final) 3" of the finished roadway surface.
  - 4. In some areas old, deteriorated asphalt surfacing may be encountered during the scarification process. If it cannot be sufficiently broken up to incorporate into the new gravel section, it shall be removed, and the volume replaced with base course material.

#### 32.11.23.02 REFERENCES

- A. South Dakota Department of Transportation (SDDOT) Standard Specifications for Roads and Bridges, most recent edition. Applicable section(s) will include Dust Control, Granular Bases and Surfacing, Aggregates for Granular Bases and Surfacing, and Dust Control Chlorides, Clay, and Milled, Reclaimed, and Salvaged Material.
- B. Manual on Uniform Traffic Control Devices (MUTCD).

#### 32.11.23.03 SUBMITTALS

- 32.11.23.03.1 Subbase.
- 32.11.23.03.2 Base Course.
- 32.11.23.03.3 Gravel Cushion.
- 32.11.23.03.4 Gravel Surfacing.
- 32.11.23.03.5 Dust Control Product and Application.
- 32.11.23.03.6 Traffic Control Plan.

## PRODUCTS

### 32.11.23.04 SUBBASE, BASE, GRAVEL CUSHION, AND GRAVEL SURFACING

- A. Subbase, base course, gravel cushion, and gravel surfacing shall conform to the Aggregates for Granular Bases and Surfacing section within the most recent edition of the SDDOT Standard Specifications for Roads and Bridges. This includes, but is not limited to, sand and rock which may be necessary to produce material of the type specified.
- B. The gravel material shall be a crushed ledge rock or limestone material meeting all the specification requirements.

### 32.11.23.05 CLAY BINDER

- A. Clay binder when required for gravel surfacing, shall conform to the Clay section within the most recent edition of the SDDOT Standard Specifications for Roads and Bridges.

### 32.11.23.06 SALVAGED SUBBASE, BASE, GRAVEL CUSHION, AND GRAVEL SURFACING

- A. Salvaged subbase, base course, gravel cushion, and gravel surfacing shall conform to the Aggregates for Granular Bases and Surfacing section within the most recent edition of the SDDOT Standard Specifications for Roads and Bridges. This includes, but is not limited to, sand and rock which may be necessary to produce material of the type specified.

### 32.11.23.07 DUST CONTROL PRODUCT

- A. Dust control material shall meet the requirements of the Dust Control and Dust Control Chlorides sections of the most recent edition of the SDDOT Standard Specifications for Road and Bridges.
- B. Dust control material shall be applied at an application rate of 0.4 -0.5 gal/sy.

## EXECUTION

### 32.11.23.08 INSTALLATION

- A. General
  1. All work shall be completed in accordance with the most recent edition of the SDDOT Standard Specifications for Roads and Bridges.
  2. Manholes, valve boxes, and inlets may be present in the existing roadway work areas.
  3. One-Call locates will be required before any work begins to provide locations for existing improvement.
  4. The Contractor will use extreme care to ensure no damage to existing infrastructure occurs.
  5. Any existing infrastructure damaged will be repaired to the Owner's satisfaction at no cost to the Owner.

6. The City of Box Elder will provide, at no cost to the project, water for gravel compaction. The Contractor will be required to attain a hydrant meter thru the normal City of Box Elder lease policy for the purpose of quantifying water used for the project.
7. The Contractor will be required to provide all necessary and appropriate traffic control signage and flaggers for the proper completion of the work in accordance with the MUTCD.

**B. UNSUITABLE MATERIAL REMOVAL**

1. Unsuitable material removed as part of the scarification process will be paid for per ton based upon actual scale tickets for each ton of material removed. Removals will only be allowed based upon individual location approval by the Engineer.

**C. MATERIAL PLACEMENT**

1. The gravel material shall be placed in accordance with Granular Bases and Surfacing section of the most recent edition of the SDDOT Standard Specifications for Road and Bridges.
2. The Contractor will be required to provide the necessary survey controls or place the new gravel with automated control system equipment which will result in the required surface profiles and elevations and finished typical section requirements.
3. Unless otherwise noted, the finished typical section shall consist of 3 inches of new gravel surfacing material placed on each edge of the roadway with additional material placed to construct a 4% crown in the middle of the roadway section.

**PRICE AND PAYMENT**

**32.11.23.09 METHOD OF MEASUREMENT**

- A. Subbase, base course, gravel cushion, gravel surfacing (including clay binder), and unsuitable material removal shall be measured on certified scales to the nearest 0.1 ton.
- B. The Contractor shall replace material lost or wasted during the processing operation at no additional expense to the City.
- C. Material placed more than the quantity needed to construct the typical section will be deducted from the final measured quantity.
- D. Water added during crushing and water mixed with granular material by a central plant will not be measured and the weight will not be subtracted from the granular material.
- E. Water added during laydown operations will not be measured and the weight will not be considered for reimbursement.
- F. Payment for gravel street resurfacing shall be per ton based upon scale tickets for each load of material delivered, placed, and accepted. Payment for gravel surfacing shall constitute full compensation for existing surface scarification and preparation, delivery, placement and watering of new gravel surfacing, compaction of new gravel, establishing line and grades for finished surface, for providing and installing dust control chloride, and

all geotechnical testing required for compaction verification including material proctors and field testing.

#### 32.11.23.10 BASIS OF PAYMENT

- A. Subbase, base course, gravel cushion, gravel surfacing (including clay binder), and unsuitable material removal shall be paid for at the contract unit price per ton.
- B. Payment will be full compensation for furnishing and placing materials, water added in a central plant, labor, equipment, test strips (if required), and all incidentals required.
- C. If roadway shaping is required, and a bid item is not provided, payment for the granular material items will be full compensation for necessary shaping work.

**END OF SECTION**

## SECTION 32.12.10 – PRIME, TACK, AND SEAL COATS

### GENERAL

#### 32.12.10.01 SUMMARY

- B. This work consists of preparing and treating a prepared surface with asphalt material and sand as required.

#### 32.12.10.02 RELATED WORK

- C. Section 32.01.14 – Asphalt Chip Sealing
- D. Section 32.12.16 – Asphaltic Paving

#### 32.12.10.03 REFERENCES

- A. South Dakota Department of Transportation (SDDOT) Standard Specifications for Roads and Bridges, most recent edition. Applicable section(s) will include Granular Bases and Surfacing; Asphalt Concrete, General; Asphalt Concrete, Class D, E, G; Aggregates for Asphalt Concrete; Aggregates for Granular Bases and Surfacing; Prime, Tack, and Seal Coats; and Asphalt Material.
- B. SDDOT Materials Manual SD 202, Method of Test for Sieve Analysis.
- C. Method of Test for Determining the Cutout Correction and In-Place Density of Asphalt Concrete by the Nuclear Gauge Method (SD 311).
- D. SDDOT Method of Test for Theoretical Maximum Specific Gravity of Asphalt Concrete Paving Mixtures (SD 312).
- E. American Association of State Highway and Transportation Officials (AASHTO) T 96-02, Resistance to Degradation of Small-Size Coarse Aggregate by Abrasion and Impact in the Los Angeles Machine.
- F. Manual on Uniform Traffic Control Devices (MUTCD).

#### 32.12.10.04 SUBMITTALS

- G. Asphalt.
- H. Sand for Blotting Prime.
- I. Sand for Flush Seal.
- J. Sand for Fog Seal.

K. Work Plan.

L. Schedule.

#### 32.12.10.05 QUALITY ASSURANCE

- A. The Contractor will furnish certification for all materials designated in the Contract along with the results of all testing performed.
- B. Weather and Seasonal Limitations
1. Application shall be made only during daylight hours, when the wind does not adversely affect the spraying operation and when the following conditions are met:
    - a. Asphalt for Prime: The application of asphalt for prime will be permitted only:
      1. When the ambient air and surface temperatures on the project are both at least 60°F in the shade.
      2. When the conditions are dry.
      3. When plans call for prime interim surfacing, the prime application shall closely follow the base finishing operation and at no time shall the prime operation be more than 3 miles from the base finishing operation. The cure time for the processed base, prime, and blotting sand application will be determined by the Engineer.
      4. Surfaces primed with cutback asphalt shall be allowed to cure for a minimum of 72 hours prior to being overlaid with asphalt concrete.
    - b. Asphalt for Tack: The application of asphalt for tack will be permitted only:
      1. When the ambient air and surface temperature on the project are both at least 35°F in the shade.
      2. When conditions are dry, emulsified asphalt may be applied when the surface is slightly damp.
      3. When plans call for prime on interim surfacing, the prime application shall closely follow the base finishing operation and at no time shall the prime operation be more than 3 miles from the base finishing operation. The cure time for the processed base, prime, and blotting sand application will be determined by the Engineer.
      4. Surfaces primed with cutback asphalt shall be allowed to cure for a minimum of 72 hours prior to being overlaid with asphalt concrete.
    - c. Asphalt for Fog Seal: The application of asphalt for fog seal will be permitted only:
      1. When the ambient air and surface temperature on the project are both at least 60°F in the shade.
      2. When conditions are dry.
    - d. Asphalt for Flush Seal: The application of asphalt for flush seal will be permitted only:
      1. Between May 1 and November 1, inclusive.
      2. When the ambient air and surface temperature on the project are both at least 50°F in the shade.
      3. When the surface is dry or slightly damp.
- E. The owner reserves the right to have the coatings or any of the component materials independently tested in accordance with the relevant contract requirements. If the testing shows defective workmanship and/or materials, payment will be withheld from

the Contractor in the amount of the testing as well as the cost of correction for all deficiencies noted.

## **PRODUCTS**

### **32.12.10.06 MATERIALS**

- A. All materials shall meet the requirements of the Prime, Tack, Fog Seal, and Flush Seal section within the most recent edition of the SDDOT Standard Specifications for Roads and Bridges.

### **32.12.10.07 EQUIPMENT**

- A. All equipment shall meet the requirements of the Prime, Tack, Fog Seal, and Flush Seal section within the most recent edition of the SDDOT Standard Specifications for Roads and Bridges.

## **EXECUTION**

### **32.12.10.08 SURFACE PREPARATION**

- A. The surface shall be thoroughly swept and cleaned of all foreign material.
- B. Appurtenances immediately adjacent to the surface to be treated shall be protected from the splatter of asphalt.
- C. Manhole covers, water shut valves, and other utility access points shall be covered to ensure liquid asphalt is not applied to them, as directed by the Engineer.
- D. Surfaces to receive a prime coat shall be satisfactorily compacted and cured.

### **32.12.10.09 MATERIAL APPLICATION**

- A. The application of all materials shall meet the requirements of the Prime, Tack, Fog Seal, and Flush Seal section within the most recent edition of the SDDOT Standard Specifications for Roads and Bridges.

### **32.12.10.10 TRAFFIC CONTROL**

- A. Allowing traffic to travel over the roadway will not be permitted until the surface has been thoroughly compacted and cooled sufficiently to resist marking or distortion.
- B. Traffic control shall be maintained during the road repair process per the SDDOT standard specifications and the MUTCD.
- C. A minimum of two electronic notifications signs shall be installed a minimum of one week before work is to commence, at each end of the work zone, to notify the traveling public of the upcoming work and recommendations to take alternate routes.

- D. The message to run on the electronic notification signs shall be approved by the Owner at least one week prior to the installation of the signs.
- E. At least one lane of traffic will be maintained at all times, unless the Engineer provides written approval of an alternate plan.
- F. Where traffic is to be maintained by means of part-width construction, the Contractor shall control traffic with identified flaggers.
- G. The Contractor shall schedule work so traffic will not be inconvenienced by long one-way lanes.

## **PRICE AND PAYMENT**

### **32.12.10.11 METHOD OF MEASUREMENT**

- A. General
  - 1. Prime, tack, and seal coats are normally considered incidental to other bid items.
  - 2. If they are included as separate items, they shall be measured to the nearest 0.1 ton, material weight.
  - 3. Scale weigh tickets will be required for all material payments.
- B. Traffic Control
  - 1. If traffic control is included on the bid schedule it shall be measured as a unit lump sum item for the entire project which shall include all items detailed in the Traffic Control section above.
  - 2. If traffic control is not included on the bid schedule it shall be incidental to the contract and the costs for same included in other bid items.

### **32.12.10.12 BASIS OF PAYMENT**

- A. General:
  - 1. Payment of all items shall be based upon the unit prices bid for each construction item and the actual measured and owner accepted quantities of materials and work items for the project.
  - 2. Payment shall constitute full compensation for providing all tools, equipment, labor, materials, and incidental items necessary and for performing all activities necessary for the proper performance and completion of all aspects of the proposed work.
- B. Prime, Tack, and Seal Coats
  - 1. If included separately on the bid schedule, the Contractor shall provide the Engineer with valid weigh tickets for all furnished, installed, and accepted prime, tack, and seal coating material which has been for which payment is requested.

**END OF SECTION**



## SECTION 32.12.16 – ASPHALTIC PAVING

### GENERAL

#### 32.12.16.01 SUMMARY

- A. Street repair work consists of the removal and disposal of assorted sections of asphalt pavement, subbase aggregates, and subgrade material in areas marked for removal by the Owner and replacement with materials approved for street repair or construction. The removed materials shall become the property of the contractor. Any value associated with the removed asphalt, or any subsurface material shall be considered when preparing the unit bid price for the asphalt removal.

#### 32.12.16.02 RELATED WORK

- A. Section 32.01.13 – Street Crack Sealing
- B. Section 32.01.14 – Asphalt Chip Sealing
- C. Section 32.12.10 – Prime, Tack, and Seal Coats
- D. Section 32.16.13 – Concrete Curb and Gutter
- E. Section 32.16.15 – Drainage Pan and Fillet

#### 32.12.16.03 REFERENCES

- A. SDDOT Standard Specifications for Roads and Bridges, most recent edition. Applicable section(s) will include Granular Bases and Surfacing; Asphalt Concrete, General; Asphalt Concrete, Class D, E, G; Aggregates for Asphalt Concrete; Aggregates for Granular Bases and Surfacing; Milled, Reclaimed, and Salvaged Material; and Asphalt Material.
- B. SDDOT Materials Manual SD 202, Method of Test for Sieve Analysis.
- C. Method of Test for Determining the Cutout Correction and In-Place Density of Asphalt Concrete by the Nuclear Gauge Method (SD 311).
- D. SDDOT Method of Test for Theoretical Maximum Specific Gravity of Asphalt Concrete Paving Mixtures (SD 312).
- E. AASHTO T 96-02, Resistance to Degradation of Small-Size Coarse Aggregate by Abrasion and Impact in the Los Angeles Machine.
- F. Manual on Uniform Traffic Control Devices (MUTCD).
- G. Dunston, P. S., Bobet, A., & McClure, T. B. (2017). *Proof rolling of foundation soil and prepared subgrade during construction* (Joint Transportation Research Program Publication No. FHWA/IN/JTRP-2017/16). West Lafayette, IN: Purdue University. <https://doi.org/10.5703/1288284316571>

32.12.16.04 SUBMITTALS

- A. Aggregate Subbase, if applicable.
- B. Aggregate Base Course.
- C. Hot-Mix Asphalt Concrete mix design to include aggregate and asphaltic material.
- D. Equipment and Processes.
- E. Schedule.

32.12.16.05 QUALITY ASSURANCE

- A. The Contractor will furnish certifications for all materials designated in the Contract along with the results of all testing performed.
- B. Weather and Seasonal Limitations
  - 1. Asphalt concrete shall only be constructed or placed when the underlying surface material is dry and unfrozen. Asphalt concrete shall not be placed when weather conditions prevent proper handling, compaction, or finishing. Temperature and seasonal limitations are as follows except as allowed by the Engineer:

MINIMUM AIR TEMPERATURES & SEASONAL LIMITATIONS				
Compacted Thickness	Surface Course		Subsurface Course & Shoulder Course	
	Minimum Temperature *	Seasonal Limits	Minimum Temperature *	Seasonal Limits
1 inch or less	45° F	May 1 to Oct 15 (inclusive)	45°	none
over 1 inch	40°F	May 1 to Oct 15 (inclusive)	40°F	none

\* Minimum air and surface temperature in the shade.

- C. The owner reserves the right to have the asphalt concrete and/or any of the component materials independently tested in accordance with the relevant contract requirements. If the testing shows defective workmanship and/or materials payment will be withheld from the Contractor in the amount of the testing as well as the cost of correction for all deficiencies noted.

D. Proof Roll Test of Subgrade and Gravel Base Course

1. Objective

- a. The objective of the proof-roll test is to verify compaction of the subgrade and aggregate base course by observing and assessing the uniformity of each travel lane over the requested test sections or areas. A proof-roll test provides a directly observable indicator of the contractor’s compaction technique effectiveness.

- b. A proof-roll inspection will be used with and does not replace other density tests such as DCPT or nuclear density.

## 2. General Notes

- a. A **minimum** of 24-hour notice is required to schedule proof-roll inspections.
- b. The cancellation of a scheduled proof roll is requested to be made 2 hours prior to the scheduled inspection.
- c. Soil/Material compaction testing results must be provided to City Engineering prior to paving.
- d. The City of Box Elder holds all rights to conduct independent testing or inspection of all active job sites within city limits.
- e. The contractor is expected to conduct their own proof-roll prior to scheduling a proof-roll with the city.
- f. Each layer must be compacted to its specified density before the next layer is placed. Each layer must be rolled until a compacted, uniform, and stable surface is achieved.
- g. Cold weather: A small test hole may be requested by city inspectors to verify that soil/materials are not frozen.
- h. **Re-inspection:**
  - i. Proof rolls that have more than two areas of deflection per road section being inspected, will require a re-inspection. The contractor/developer will be billed for "Subsequent Proof of same Road" as stated in Engineering services under Public Works Fees per "City of Box Elder Ordinance No. 717".

## 3. Subgrade

- a. **Compaction:**
  - i. Table 1 on page 120 of *Standards and Specifications for Roads and Bridges SDDOT 2015*.
  - ii. Density requirement of 95% or greater.
  - iii. **Manholes, Storm Sewer Inlets and Crossings:** Special attention must be addressed to areas around manholes, storm sewer infrastructure, and underground utilities to ensure proper compaction.
- b. Top 12 inches of subgrade are to be compacted. Proof-roll inspection should take place directly after compaction is complete for ideal moisture conditions. A proof-roll inspection should not be conducted if more than 15 hours have passed after compaction being completed.
- c. The use of geo grid, geo fabric, other soil stabilization products and or basecourse over 6-inch depth does NOT negate the subgrade proof roll procedure or failure criteria.
- d. The inspection will consist of a minimum of one pass per travel lane. Additional inspection passes may be conducted at the discretion of the inspector representing the City of Box Elder.
- e. To ensure the inspection can be successfully conducted, the surface must be smooth, free of ruts, and not consist of loose surface material that could interfere with the inspection process.

## Subgrade Proof Roll Procedure

Procedure	
Speed	Walking speed determined by inspector, max 5 mph.
Passes	Minimum 1 pass per travel lane.
Vehicle	
<b>Tandem Axle Truck</b>	Tandem-axle truck
Weight	20-ton minimum (total weight of loaded truck)
Tires	Dual rear wheels. Tire size and pressure as required for highway operations.
Test axle	Rear axle
Passing Criteria	
New Construction	Ruts: Less than 1-inch depth.
	Pumping: Less than 1-inch deflection
	No Surface cracking
	Soil Probe: Penetration depth less than 1.5 inch, no visible moisture in soil at depth.
Reconstruction or stabilized subgrade	Ruts: Less than 0.5-inch depth.
	Pumping: Less than 0.5-inch depth.
	No Surface cracking
	Soil Probe: Penetration depth less than 0.5 inch, no visible moisture in soil at depth.
<i>Deflection: Vertical movement under load, this includes plastic and elastic deformation.</i>	
<i>Pumping: Rebounding vertical heave of soil from test load.</i>	
<i>Ruts: Permanent deflection from the load being applied.</i>	

#### 4. Gravel Base Course

##### a. **Compaction:**

- i. "Base Course shall be compacted to 97% of the maximum dry density." - SDDOT *Standards and Specifications for Roads and Bridges SDDOT 2015*.
- b. The inspection will consist of a minimum of one pass per travel lane. Additional inspection passes may be conducted at the discretion of the inspector representing the City of Box Elder.
- c. To ensure the inspection can be successfully conducted, the surface must be smooth, free of ruts, and not consist of loose surface material that could interfere with the inspection process.

### Gravel Base Course Proof Roll Procedure

<b>Procedure</b>	
Speed	Walking speed determined by inspector, max 5 mph.
Passes	Minimum 1 pass per travel lane.
<b>Vehicle</b>	
<b>Tandem Axle Truck</b>	Tandem-axle truck
Weight	20-ton minimum (total weight of loaded truck)
Tires	Dual rear wheels. Tire size and pressure as required for highway operations.
Test axle	Rear axle
<b>Passing Criteria</b>	
New Construction	Ruts: Less than 0.5-inch depth.
	Pumping: Less than 0.5-inch deflection.
	No Surface cracking
	Soil Probe: Penetration depth less than 1.5 inch, no visible moisture in soil at depth.
Reconstruction or stabilized subgrade	No Ruts
	No Pumping or Deflection
	No Surface cracking
	Soil Probe: Penetration depth less than 0.5 inch, no visible moisture in soil at depth.
<i>Deflection: Vertical movement under load, this includes plastic and elastic deformation.</i>	
<i>Pumping: Rebounding vertical heave of soil from test load.</i>	
<i>Ruts: Permanent deflection from the load being applied.</i>	

### Checklist: Proof Roll Inspections

To pass, each section (Subgrade or Base Course) must have all YES circled. The test is failed if a single NO, is circled.

<b>Project Name:</b>	
<b>New or Re-Construction:</b>	
<b>Road Name &amp; Section:</b>	
<b>City Inspectors:</b>	
<b>Test Vehicle Used:</b>	
<b>Number of lanes tested:</b>	
<b>Test Number (re-test?)</b>	

#### Subgrade

<i>Test Date:</i>	<i>Circle/Select</i>	
Walking pace? (under 5 mph)	YES	NO
Ruts: (See Passing Criteria)	YES	NO
Pumping: (See Passing Criteria)	YES	NO
Less than 3 areas of deflection.	YES	NO
Soil Probe: (See Passing Criteria)	YES	NO
	<b>Pass</b>	<b>Fail</b>

Comments:

#### Base Course

<i>Test Date:</i>	<i>Circle/Select</i>	
Walking pace? (under 5 mph)	YES	NO
Ruts: (See Passing Criteria)	YES	NO
Pumping: (See Passing Criteria)	YES	NO
Less than 3 areas of deflection?	YES	NO
Soil Probe: (See Passing Criteria)	YES	NO
	<b>Pass</b>	<b>Fail</b>

Comments:

## PRODUCTS

### 32.12.16.06 AGGREGATE SUBBASE

- A. Aggregate Subbase material shall meet the requirements of “Subbase” aggregate as defined within the most recent edition of the SDDOT Standard Specifications for Roads and Bridges

### 32.12.16.07 AGGREGATE BASE COURSE

- A. Aggregate base course material shall meet the requirements of “Aggregate Base Course” as defined within the most recent edition of the SDDOT Standard Specifications for Roads and Bridges

### 32.12.16.08 HOT MIX ASPHALT

- A. Hot-mix asphalt concrete shall consist of two 2” lifts of asphalt cement pavement. The asphalt pavement shall be Class E, Type 1, PG 64-28 meeting the requirements of the Aggregates for Asphalt Concrete and Asphalt Material sections of the most recent edition of the SDDOT Standard Specifications for Roads and Bridges, unless otherwise specified. A mix design for the asphalt pavement shall be submitted to the Owner at least 2 weeks prior to starting work and approved before any work may begin.

### 32.12.16.09 EQUIPMENT

#### A. Pavers

1. Self-propelled pavers shall be equipped with sufficient capacity hopper having a bottom conveyer, an activated screed or activated strike-off assembly, heated if necessary, and is capable of laying specified lane widths.
2. The paver shall provide an accurate, smooth, uniform-textured spread and provide preliminary compaction of the mixture.
3. An attachment shall be provided on the paver that will place a satisfactory beveled edge on the mat if called for on the plans.
4. Pavers shall be equipped so that the height and transverse slope of the screed may be manually controlled.
5. They shall be capable of depth adjustments from 3/4 inch to not more than 3 inches and width adjustments to spread the mixture in strips of less than 10 feet in width, in steps of 1 foot or less, to a minimum width of 8 feet.
6. They shall be equipped with blending or joint leveling devices for smoothing and adjusting all longitudinal joints between adjacent strips of courses of the same thickness.

#### B. Rollers

1. Rollers for compacting the asphalt concrete shall be of the self-propelled type, capable of producing a smooth surface finish.
2. The number and weight of rollers furnished shall be of sufficient size to compact the mix to the required density while it is in a workable condition.
3. Rollers shall be equipped to prevent "pickup" on the tires or drums.
4. Provisions for uniform moistening of the drums or tires with water or water detergent solution or suitably enclosing the roller to prevent heat loss from the tires may be required.
5. The use of fuel oil or other petroleum solvents to prevent "pickup" will not be permitted.
6. Measures shall be taken to prevent oil, grease, or fuels from being dropped on the mat surface.
7. The rollers shall be capable of being reversed smoothly, without shoving or tearing the asphalt concrete, and there shall be no excessive lost motion in the steering mechanism.

## **EXECUTION**

### **32.12.16.10 ASPHALT REMOVAL**

- A. The Asphalt removal shall consist of saw cutting the existing pavement along the lines established by the Owner, removal of the asphalt, subbase aggregate and subgrade material down to a minimum depth of 16 inches below finished grade. The Owner reserves the right to increase the depth of removals if unsuitable material is encountered.
- B. All demolition work shall be accomplished in such manner as to avoid damage to adjacent roadway, sidewalk, curbing and/or property.

### **32.12.16.11 GRANULAR BASES**

- A. Aggregate materials shall be installed per the Granular Bases and Surfacing section of the most recent edition of the SDDOT Standard Specifications for Roads and Bridges.
- B. Submittals of all proposed materials to be used shall be approved prior to the commencement of work.
- C. Submittals for the aggregate materials shall include gradations tests showing compliance with all test requirements and a Proctor test showing maximum unit weight at optimum moisture.

### **32.12.16.12 ASPHALT PLACEMENT**

- A. General



1. Unless otherwise indicated, asphalt paving shall consist of the installation of 6 inches of compacted subbase aggregate (or more if extra depth removal required), 6 inches of compacted aggregate base course, and 4 inches of hot mix asphalt cement pavement placed in 2 lifts. The depth of all pavement section layers may be adjusted based upon the recommendations from the "Geotechnical Pavement Design Report".
2. The hot-mix asphalt concrete shall be installed per the requirements of the Asphalt Concrete section of the most recent edition of the SDDOT Standard Specifications for Roads and Bridges.

#### B. Transportation and Delivery of the Mixture

1. The mixture shall be transported from the plant to the point of use in pneumatic-tired vehicles.
2. The boxes of the vehicles shall be tight, clean, and smooth.
3. Boxes shall be cleaned only with lime water, soap, or a detergent solution.
4. Oil, diesel fuel, or other petroleum solvents shall not be used.
5. No material shall be used which could adversely affect the asphalt concrete.
6. Excess solution in the box shall be disposed of before the vehicle is loaded.
7. Operations between the times of sunset and sunrise shall be permitted only when approved by the Engineer.
8. When directed by the Engineer, each load shall be covered with a satisfactory tarpaulin.

#### C. Tacking, Spreading, and Compacting

1. The surface on which the asphalt concrete is to be placed, including all vertical contact faces, shall be tacked in accordance with Section 32.12.10, unless otherwise shown on the plans or directed by the Engineer.
2. The tack coat shall be allowed a cure period, as determined by the Engineer, prior to asphalt concrete placement.
3. Asphalt concrete shall be placed by self-propelled pavers.
4. Handwork is permissible in inaccessible or odd-shaped areas.
5. A shoe attachment should be used to match the longitudinal joint(s) on the final paver pass(es) of the top lift unless otherwise directed by the Engineer.
6. The "temperature of mixture on delivery to the road (or construction site)" shall be the temperature of the mix just prior to placement.
7. Spot leveling and repair of the existing surface with asphalt concrete will be required in advance of the paver laid courses as designated by the Engineer.
8. Potholes and areas of localized disintegration shall be cleaned of loose material, squared, tacked, leveled with asphalt concrete, and compacted by methods satisfactory to the Engineer.
9. Spot leveling may be blade laid in lifts not exceeding 3 inches of uncompacted depth.
10. Compaction shall be by five complete coverages as stated in the Specified Roller Coverage method, except a steel-face roller will not be required.
11. Continuous and uniform operation shall be maintained.
12. Trucks shall be available for continuous operation of the plant.
13. Paver operation shall be uniform and consistent with the production at the plant.
14. Stops and starts shall be restricted to a minimum.

15. Laydown operations shall proceed from the center to the shoulders of the roadbed surface.
16. The center joints of succeeding lifts shall be offset approximately 6 inches.
17. The center joint of the top lift shall be located on the centerline.
18. Longitudinal joints other than at the lane lines will not be permitted in the top lift.
19. In curb and gutter sections, laydown may proceed from the gutter line to the centerline when directed.
20. Transverse joints of the final lift shall be formed by cutting back, with a saw on the previous run, to expose the full depth of the course.
21. When finished, the transverse joint of all lifts shall have a uniform texture and comply with the straight edge requirement.
22. Waste material resulting from forming joints and temporary ramps shall be removed and disposed of.
23. Excessive pulling or segregation of the mix shall warrant suspension of operations.
24. Immediately after the mix has been placed and any surface irregularities adjusted, it shall be thoroughly and uniformly compacted by rolling to the specified density requirements for the class of asphalt concrete designated.
25. The in-place density shall be determined using of a nuclear density testing machine.
26. Test frequency shall be as specified in the Density Tests/Frequency section herein.
27. Rollers shall be operated at a slow, uniform speed not to exceed 5 miles per hour.
28. Unless otherwise permitted by the Engineer, static steel-faced rollers shall be operated with the drive wheel nearest the paver.
29. When abutting a previously laid lane and when breakdown rolling is being accomplished with a steel-faced roller, the longitudinal joint shall be rolled first by operating the roller on the finished lane with approximately 6 inches of the roller projecting on the new lane.
30. The surface of each lift shall be free of waves and other irregularities. The surface of the final lift shall be checked with a 10-foot straight edge, furnished by the Contractor.
31. The variation of the surface from the straight edge between any two contact points shall not exceed 0.02 foot.
32. The crown, on all lifts, as indicated by checking with a 10-foot straight edge, shall be within 0.04 foot of specified crown in any 10-foot length.
33. There shall be an attempt to correct irregularities before the temperature of the asphalt mix drops below 175°F.
34. The longitudinal profile can be improved by using a grinder with diamond blades mounted on a horizontal shaft and other methods when approved by the Engineer.
35. Areas that have been ground shall not be left smooth or polished but shall have a uniform texture equal in roughness to the surrounding unground asphalt concrete.
36. Grinding shall be daylighted to the outside edge of the pavement.
37. Ground surfaces shall be flushed sealed.
38. Under no circumstances shall operations continue when it becomes evident final rolling is not producing a smooth, uniform, compacted surface free from roller marks and other irregularities.
39. As a normal sequence rolling shall be longitudinal, commencing at the outer edges of the mat and progressing toward the center in straight, parallel strips, overlapping at least 6 inches.
40. Rollers shall proceed straight-forward and return in the same path.
41. Turning the rollers to position them for the next pass shall occur at a point where the pavement temperature has cooled sufficiently to resist damage.

42. The Contractor shall vary the points of reversal to prevent a transverse crease.
43. In order to prevent deformation, rollers shall not stand idle on any part of the mat, which has not been completed and cooled sufficiently to resist deformation.
44. The beveled edge shall be compacted by methods satisfactory to the Engineer during the breakdown or intermediate rolling.
45. The mix shall be compacted on the road by one of the following methods.
46. Unless otherwise specified in the contract, the Specified Density Method shall be used.

#### D. Specified Density Method

1. The mix shall be compacted to the density specified for the class of asphalt concrete designated.
2. The percent of density shall be based on the maximum specific gravity of the test specimens prepared in the field in accordance with SD 312.
3. The compacted density of the asphalt concrete shall be as determined by SD 311.
4. Compaction of mix placed on entrances to residences or businesses and intersecting road approaches shall be compacted by the Specified Roller Coverage Method.
5. Density of asphalt concrete in place shall be in accordance with SD 311.
6. Rolling shall be completed before the temperature of the in-place mix drops below 180°F.

#### E. Specified Roller Coverages

1. The mix shall be compacted by at least four complete coverages with pneumatic-tired rollers and at least one complete coverage with steel faced rollers.
2. Breakdown rolling may be accomplished by steel-faced rollers when approved by the Engineer.
3. Self-propelled pneumatic-tired rollers shall cover an overall surface width of at least 60 inches and furnish a minimum rolling pressure of 250 pounds per inch of roller width.
4. Self-propelled, tandem, smooth steel rollers (two steel drums operating in the same track) shall furnish a minimum rolling pressure of 275 pounds per inch of roller width.
5. Rolling shall proceed on the mat as soon as laydown is completed.
6. Completion of rolling on any segment shall not lag behind the laydown by more than 1000 feet.
7. During periods of cool weather, this maximum distance between laydown and final rolling shall be reduced as directed by the Engineer.
8. Compaction to the specified density recommended within the pavement design be required; however, additional roller coverages may be required in order to obtain a smooth surface finish.
9. When directed, the Contractor shall cool, saw, and remove an undamaged 6-inch square sample or a 7-inch diameter round sample from an area designated and repair the hole to the satisfaction of the Engineer.
10. Rolling between the times of sunset and sunrise shall be permitted only when approved by the Engineer.

### 32.12.16.13 TESTING

#### A. Density Tests

1. The Contractor shall submit the following test data for each class of asphalt concrete:
  - a. One (1) Standard Density at the start of work and each time the mix or source of material is changed;
  - b. One in-place, non-destructive (nuclear gauge) density test per day per 200-ton lot of mainline paving mix;
  - c. One in-place, non-destructive (nuclear gauge) density test per day per 250-square yards of patching.
2. Testing shall be incidental to the contract and will not be paid for directly, except as otherwise noted on the Bid Schedule.
3. In addition to this testing, the Contractor may be required to remove and test in-place asphalt concrete to determine field densities by sawing or coring samples from areas to be determined by the Engineer.
4. All sampling and testing shall be done by certified testing laboratory personnel, and all test results shall be submitted to the Engineer.
5. Failing density tests shall result in an adjustment of the warranty period and the contract unit price in accordance with the following table for all classes of asphalt concrete:

Amount of Deviation	0% to -1%	-1% to -2%	-2% to -3%	-3% to -4%
Amount of Deduction	0% to 5%	5% to 10%	10% to 20%	20% to 30%
Additional Warranty Period	1 year	2 years	3 years	4 years

6. The amount of deviation shall be the difference between the specified density and the average of all densities for that class of asphalt concrete if this average is less than the specified density.
7. The City reserves the right to order additional tests.
8. The Contractor shall pay for those additional tests that fail to meet specified density, and the City will pay for those additional tests that do meet the specified density.
9. The Engineer or his representative shall be present for all field sampling and lab testing performed for the Contractor.
10. Failure to notify the City of pending sampling or testing could result in rejection of submitted data and re-testing by in-place methods.
11. All required data shall be received by the Engineer before payment for pavement exceeds 75% of the total quantity.

### 32.12.16.14 ASPHALT PATCHING

#### A. GENERAL

1. Asphalt replacement for utility installation, repair, or similar work shall comply with the requirements herein and as follows:
  - a. Hot-mix asphalt patching material shall be Class E, Type 1, PG 64-22.
  - b. Minimum Patch Depth:
    - i. Unless specified otherwise, all permanent asphalt patches shall be placed to a minimum depth of 5 inches.
    - ii. Should existing pavement depths be greater than 5 inches, the permanent patch shall match the depth of the existing pavement or as directed by the Engineer.
  - c. Minimum Patch Width
    - i. Minimum patch width shall be 6 feet or the initial saw width for the proposed trench width plus 2 feet (one foot on each side of the initial saw cut), whichever is greater.
    - ii. All mainline, permanent patches equal to or greater than 8 feet in width and longer than 40 feet shall be placed with a paving machine.
    - iii. The use of Layton pavers is prohibited.

#### B. SURFACE TOLERANCE

1. The patch surface shall be tested with a 10-foot straightedge.
2. The maximum permissible surface deviation shall be  $\frac{1}{4}$  inch in ten feet.
3. The measurements will be made parallel to traffic and up to within one foot of the edge of the existing pavement.
4. Deviation within one foot of the existing pavement shall be no greater than that measured on the adjacent existing pavement.
5. Areas that exceed the permissible deviation shall be subject to corrective action as directed by the Engineer.
6. Any corrective measures shall produce a structurally sound, smooth riding surface.

#### C. PLACEMENT

1. Concrete streets with asphalt overlays shall be replaced as described in Section 32.13.13.
2. Asphalt overlay thickness shall match existing thickness and shall extend at least 6 inches beyond edges formed by new and existing concrete paving.
3. The asphalt shall be tapered at a maximum 10:1 slope longitudinally on each side of any drainage pans and on any areas of existing streets where the overlay begins or ends.
4. The edges of the new asphalt overlay patch shall be tapered to meet the gutter lip as indicated on the Drawings.
5. Under certain conditions where localized ponding problems exist on the existing pavement, the Engineer may require the Contractor to overlay all the way to the face of the curb.

#### D. TEMPORARY PATCHING

1. If hot-mix asphalt will not be available for a significant period, the Contractor shall place a temporary cold-mix patch or overlay as directed by the Engineer.
2. The Engineer shall determine if placement of the cold-mix is necessary.
3. The cold-mix shall conform to the requirements below.

4. As soon as the hot-mix asphalt becomes available, the Contractor shall remove the remaining cold-mix patch and immediately replace it with the hot-mix asphalt patch.
5. The Contractor will be responsible for satisfactorily maintaining the cold-mix patch until the permanent patch is placed.

E. MAINTENANCE

1. The Contractor shall be responsible for the maintenance of the work during construction and until final acceptance.
2. Maintenance shall include protection and repair of the prepared base course, tack coat, wearing surface mat, shoulders, and seal course.
3. Rich or bleeding areas, breaks, raveled spots, or other nonconforming areas in the wearing surface or base shall be corrected during such maintenance period.

32.12.16.15 COLD-MIX ASPHALT

A. General

1. This work consists of furnishing and placing a temporary course of cold-mix asphalt concrete on a prepared surface.

B. Materials

1. Aggregate: The aggregate shall conform to the requirements of the following table:

Passing 0.5 inch sieve	100%
Passing No. 4 sieve	80%
Passing No. 8 sieve	40-60%
Passing No. 40 sieve	12-32%
Passing No. 200 sieve	4-12%

Note: 100% of the aggregate retained on the Number 4 or larger sieve shall have two or more fractured faces.

2. Asphalt:

- a. The cold-mix asphalt material shall be MC-250.
- b. When limestone rock is used, the asphalt content shall be 4½% to 5%.
- c. When river rock is used, the asphalt content shall be 5½% to 6%.

C. Construction Requirements

1. The cold-mix asphalt shall be placed at the locations and depths specified on the plans, in the detailed specifications, and/or as directed by the Engineer.
2. Should any maintenance work be required on any installed cold-mix asphalt, the Contractor shall do so within 48 hours of receiving notice from the Engineer.

3. If the Contractor does not accomplish the necessary work within 48 hours, the City will have the work done and will charge the Contractor 1½ times the cost incurred.

#### 32.12.16.16 TRAFFIC CONTROL

- A. Allowing traffic to travel over the roadway will not be permitted until the surface has been thoroughly compacted and cooled sufficiently to resist marking or distortion.
- B. Traffic control shall be maintained during the road repair process per the SDDOT standard specifications and the MUTCD.
- C. A minimum of two electronic notification signs shall be installed a minimum of one week before work commences, at each end of the work zone, to notify the traveling public of the upcoming work and recommendations to take alternate routes.
- D. The message to run on the electronic notification signs shall be approved by the Owner at least one week prior to the installation of the signs.
- E. At least one lane of traffic will be maintained at all times, unless the Engineer provides written approval of an alternate plan.
- F. Where traffic is to be maintained by means of part-width construction, the Contractor shall control traffic with identified flaggers.
- G. The Contractor shall schedule work so traffic will not be inconvenienced by long one-way lanes.

### PRICE AND PAYMENT

#### 32.12.16.17 METHOD OF MEASUREMENT

- A. Asphalt Paving and Patching
  1. Asphalt paving shall be measured to the nearest 0.1 ton, material weight.
  2. The mixture of mineral aggregate and asphalt will be weighed after mixing, and no deduction will be made for the weight of the asphalt included in the mixture.
  3. Material called for in the plans or as directed by the Engineer which is placed for use as temporary surfacing will be paid for in the same manner as permanent surfacing.
  4. Subbase aggregate, aggregate base course, and asphalt cement paving will be measured to the nearest 0.1 ton of actual material delivered, placed, and accepted by the Owner.
  5. Scale weigh tickets will be required for all material payments.
- B. Asphalt Removal
  1. Asphalt removal shall be measured to the nearest square yard per area of actual material removed.

2. If included as a separate line item on the bid schedule, asphalt saw cutting shall be measured to the nearest lineal foot per area of actual saw cutting performed for the necessary removals.
3. Excavation shall be measured to the nearest cubic yard of actual subgrade material removed for the reconstruction efforts. Excavation will not include the thickness of the asphalt pavement section.

C. Traffic Control

1. If traffic control is included on the bid schedule it shall be measured as a unit lump sum item for the entire project which shall include all items detailed in the Traffic Control section above.
2. If traffic control is not included on the bid schedule it shall be incidental to the contract and the costs for same included in other bid items.

32.12.16.18 BASIS OF PAYMENT

A. General:

1. Payment of all items shall be based upon the unit prices bid for each construction item and the actual measured and owner accepted quantities of materials and work items for the project.
2. Unit Price Payment shall constitute full compensation for providing all tools, equipment, labor, materials, and incidental items necessary and for performing all activities necessary for the proper performance and completion of all aspects of the proposed work.

C. Asphalt Pavement & Patching

1. The Contractor shall provide Engineer with valid weigh tickets for all asphalt paving and patching work, furnished and installed.

**END OF SECTION**



## SECTION 32.13.13 – CONCRETE PAVING

### GENERAL

#### 32.13.13.01 SUMMARY

- A. The work to be completed under this contract shall include removal of concrete street section, as indicated on the Drawings, along with the base course and any subbase material deemed by the Engineer to be inadequate, and/or installation of new Portland Cement Concrete paving along with any required subbase and base course, and/or any concrete pavement spalling repairs.

#### 32.13.13.02 RELATED WORK

- A. Section 03.11.13 – Concrete Formwork
- B. Section 32.16.13 – Concrete Curb and Gutter

#### 32.13.13.03 REFERENCES

- A. South Dakota Department of Transportation (SDDOT) Standard Specifications for Roads and Bridges, most recent edition. Applicable section(s) will include Granular Bases and Surfacing, Concrete Spall Repair, Fly Ash, Portland Cement, Air-Entraining Admixtures, Chemical Admixtures for Concrete, Water for Use in Portland Cement Concrete, Masonry Mortar Sand and Epoxy Mortar Sand, Fine Aggregate for Use in Portland Cement Concrete, Coarse Aggregate for Use in Portland Cement Concrete, Concrete Curing Materials, Preformed Expansion Joint Filler for Concrete, Concrete Joint Sealer, Aggregates for Granular Bases and Surfacing, and Concrete Reinforcement.
- B. SDDOT Materials Manual SD 202, Method of Test for Sieve Analysis.
- C. American Association of State Highway and Transportation Officials T 96-02, Resistance to Degradation of Small-Size Coarse Aggregate by Abrasion and Impact in the Los Angeles Machine.
- D. Manual on Uniform Traffic Control Devices (MUTCD).
- E. Dunston, P. S., Bobet, A., & McClure, T. B. (2017). *Proof rolling of foundation soil and prepared subgrade during construction* (Joint Transportation Research Program Publication No. FHWA/IN/JTRP-2017/16). West Lafayette, IN: Purdue University. <https://doi.org/10.5703/1288284316571>

#### 32.13.13.04 SUBMITTALS

- A. Aggregate Subbase, if applicable.
- B. Aggregate Base Course, if applicable.
- C. Portland Cement Mix.

- D. Steel Dowel Bars, if applicable.
- E. Concrete Curing Materials.
- F. Concrete Quality Control Test Results.
- G. Traffic Control Plan, if applicable.

#### 32.13.13.05 QUALITY ASSURANCE

- A. The Contractor will furnish certifications for all materials designated in the Contract along with the results of all testing performed.
- B. The owner reserves the right to have the concrete and/or any of the component materials independently tested in accordance with the relevant contract requirements. If the testing shows defective workmanship and/or materials payment will be withheld from the Contractor in the amount of the testing as well as the cost of correction for all deficiencies noted.

#### C. Proof Roll Test of Subgrade and Gravel Base Course

#### D. Objective

1. The objective of the proof-roll test is to verify compaction of the subgrade and aggregate base course by observing and assessing the uniformity of each travel lane over the requested test sections or areas. A proof-roll test provides a directly observable indicator of the contractor's compaction technique effectiveness.
2. A proof-roll inspection will be used with and does not replace other density tests such as DCPT or nuclear density.

#### E. General Notes

1. A **minimum** of 24-hour notice is required to schedule proof-roll inspections.
2. Cancellation of a scheduled proof roll should be requested at a minimum of 2 hours prior to the scheduled inspection.
3. Soil/Material compaction testing results must be provided to City Engineering prior to paving.
4. The City of Box Elder holds all rights to conduct independent testing or inspection of all active job sites within city limits.
5. The contractor is expected to conduct their own proof-roll prior to scheduling a proof-roll with the city.
6. Each layer must be compacted to its specified density before the next layer is placed. Each layer must be rolled until a compacted, uniform, and stable surface is achieved.
7. Cold weather: A small test hole may be requested by city inspectors to verify that soil/materials are not frozen.
8. **Re-inspection:**
  - i. Proof rolls that have more than two areas of deflection per road section being inspected, will require a re-inspection. The contractor/developer will be billed for "Subsequent Proof of same Road" as stated in Engineering services under Public Works Fees per "City of Box Elder Ordinance No. 717".

F. Subgrade

1. **Compaction:**

- i. Table 1 on page 120 of *Standards and Specifications for Roads and Bridges SDDOT 2015*.
  - ii. Density requirement of 95% or greater.
  - iii. **Manholes, Storm Sewer Inlets and Crossings:** Special attention must be addressed to areas around manholes, storm sewer infrastructure, and underground utilities to ensure proper compaction.
2. Top 12 inches of subgrade are to be compacted. Proof-roll inspection should take place directly after compaction is complete for ideal moisture conditions. A proof-roll inspection should not be conducted if more than 15 hours have passed after compaction being completed.
  3. The use of geo grid, geo fabric, other soil stabilization products and or basecourse over 6-inch depth does NOT negate the subgrade proof roll procedure or failure criteria.
  4. The inspection will consist of a minimum of one pass per travel lane. Additional inspection passes may be conducted at the discretion of the inspector representing the City of Box Elder.
  5. To ensure the inspection can be successfully conducted, the surface must be smooth, free of ruts, and not consist of loose surface material that could interfere with the inspection process.

**Subgrade Proof Roll Procedure**

Procedure	
Speed	Walking speed determined by inspector, max 5 mph.
Passes	Minimum 1 pass per travel lane.
Vehicle	
<b>Tandem Axle Truck</b>	Tandem-axle truck
Weight	20-ton minimum (total weight of loaded truck)
Tires	Dual rear wheels. Tire size and pressure as required for highway operations.
Test axle	Rear axle
Passing Criteria	
New Construction	Ruts: Less than 1-inch depth.
	Pumping: Less than 1-inch deflection
	No Surface cracking
	Soil Probe: Penetration depth less than 1.5 inch, no visible moisture in soil at depth.
Reconstruction or stabilized subgrade	Ruts: Less than 0.5-inch depth.
	Pumping: Less than 0.5-inch depth.
	No Surface cracking
	Soil Probe: Penetration depth less than 0.5 inch, no visible moisture in soil at depth.
<i>Deflection: Vertical movement under load, this includes plastic and elastic deformation.</i>	
<i>Pumping: Rebounding vertical heave of soil from test load.</i>	

*Ruts: Permanent deflection from the load being applied.*

G. Gravel Base Course

d. **Compaction:**

- i. "Base Course shall be compacted to 97% of the maximum dry density." - SDDOT *Standards and Specifications for Roads and Bridges SDDOT 2015.*
- e. The inspection will consist of a minimum of one pass per travel lane. Additional inspection passes may be conducted at the discretion of the inspector representing the City of Box Elder.
- f. To ensure the inspection can be successfully conducted, the surface must be smooth, free of ruts, and not consist of loose surface material that could interfere with the inspection process.

**Gravel Base Course Proof Roll Procedure**

<b>Procedure</b>	
Speed	Walking speed determined by inspector, max 5 mph.
Passes	Minimum 1 pass per travel lane.
<b>Vehicle</b>	
<b>Tandem Axle Truck</b>	Tandem-axle truck
Weight	20-ton minimum (total weight of loaded truck)
Tires	Dual rear wheels. Tire size and pressure as required for highway operations.
Test axle	Rear axle
<b>Passing Criteria</b>	
New Construction	Ruts: Less than 0.5-inch depth.
	Pumping: Less than 0.5-inch deflection.
	No Surface cracking
	Soil Probe: Penetration depth less than 1.5 inch, no visible moisture in soil at depth.
Reconstruction or stabilized subgrade	No Ruts
	No Pumping or Deflection
	No Surface cracking
	Soil Probe: Penetration depth less than 0.5 inch, no visible moisture in soil at depth.
<i>Deflection: Vertical movement under load, this includes plastic and elastic deformation.</i>	
<i>Pumping: Rebounding vertical heave of soil from test load.</i>	
<i>Ruts: Permanent deflection from the load being applied.</i>	

## Checklist: Proof Roll Inspections

To pass, each section (Subgrade or Base Course) must have all YES circled. The test is failed if one NO is circled.

<b>Project Name:</b>	
<b>New or Re-Construction:</b>	
<b>Road Name &amp; Section:</b>	
<b>City Inspectors:</b>	
<b>Test Vehicle Used:</b>	
<b>Number of lanes tested:</b>	
<b>Test Number (re-test?)</b>	

### Subgrade

<i>Test Date:</i>		<i>Circle/Select</i>	
Walking pace? (under 5 mph)		YES	NO
Ruts: (See Passing Criteria)		YES	NO
Pumping: (See Passing Criteria)		YES	NO
Less than 3 areas of deflection.		YES	NO
Soil Probe: (See Passing Criteria)		YES	NO
		<b>Pass</b>	<b>Fail</b>

Comments:

### Base Course

<i>Test Date:</i>		<i>Circle/Select</i>	
Walking pace? (under 5 mph)		YES	NO
Ruts: (See Passing Criteria)		YES	NO
Pumping: (See Passing Criteria)		YES	NO
Less than 3 areas of deflection?		YES	NO
Soil Probe: (See Passing Criteria)		YES	NO
		<b>Pass</b>	<b>Fail</b>

Comments:

## PRODUCTS

### 32.13.13.06 AGGREGATE SUBBASE

- A. Aggregate subbase material shall meet the requirements of “Subbase” aggregate as defined within the Aggregates for Granular Bases and Surfacing section of the most recent edition of the SDDOT Standard Specifications for Roads and Bridges.

### 32.13.13.07 AGGREGATE BASE COURSE

- A. Aggregate base course material shall meet the requirements of “Aggregate Base Course” as defined within the Aggregates for Granular Bases and Surfacing section of the most recent edition of the SDDOT Standard Specifications for Roads and Bridges.

### 32.13.13.08 PORTLAND CEMENT CONCRETE

- A. Portland cement concrete paving material shall meet the requirements of the Fly Ash, Portland Cement, Air-Entraining Admixtures, Chemical Admixtures for Concrete, Water for Use in Portland Cement Concrete, Fine Aggregate for Use in Portland Cement Concrete, and Coarse Aggregate for Use in Portland Cement Concrete sections of the most recent edition of the SDDOT Standard Specifications for Roads and Bridges.
- B. The mix design may incorporate a fiber mesh additive designed to increase the concrete tensile strength if approved or directed by the Engineer.
- C. Type II cement shall be used for all concrete pavement.
- D. The mix design shall be for a minimum 4,000 psi concrete mix.
- E. Portland cement concrete spall repair material shall meet the requirements of the Concrete Spall Repair and Masonry Mortar Sand and Epoxy Mortar Sand sections of the most recent edition of the SDDOT Standard Specifications for Roads and Bridges.

### 32.13.13.09 CONCRETE CURING MATERIALS

- A. Concrete curing materials shall meet the requirements of the Concrete Curing Materials section of the most recent edition of the SDDOT Standard Specifications for Roads and Bridges.

### 32.13.13.10 PREFORMED EXPANSION JOINT FILLER FOR CONCRETE

- A. Preformed expansion joint filler shall meet the requirements of the Preformed Expansion Joint Filler for Concrete section of the most recent edition of the SDDOT Standard Specifications for Roads and Bridges.

### 32.13.13.11 CONCRETE JOINT SEALER

- A. Concrete joint sealer shall meet the requirements of the Concrete Joint Sealer for Concrete section of the most recent edition of the SDDOT Standard Specifications for Roads and Bridges.

#### 32.13.13.12 STEEL DOWEL BARS

- A. The new steel dowel bars shall meet the requirements from the Concrete Reinforcement section of the most recent edition of the SDDOT Standard Specifications for Roads and Bridges.

#### 32.13.13.13 DOWEL BAR EPOXY RESIN

- A. Dowel bar epoxy resin shall meet the requirements from the Concrete Reinforcement section of the most recent edition of the SDDOT Standard Specifications for Roads and Bridges.
- B. Dowel bar epoxy resin shall be designed specifically for this application.
- C. The intended epoxy resin shall be submitted to the Engineer for approval at least one week prior to its first application.

### **EXECUTION**

#### 32.13.13.14 INSTALLATION

- A. All work shall be completed in accordance with the most recent edition of the SDDOT Standard Specifications for Roads and Bridges.
- B. Manholes, valve boxes, and inlets may be present in the existing roadway work areas. One-Call locates will be required before any work begins to provide locations for existing improvement. The Contractor will use extreme care to insure no damage to existing infrastructure occurs. Any existing infrastructure damaged will be repaired to the Owner's satisfaction at no cost to the Owner.
- C. Water for gravel compaction may be obtained from the City of Box Elder. The Contractor will be required to attain a hydrant meter thru the normal City lease policy or may purchase water thru the coin operated bulk meter on S. Ellsworth Road.
- D. Unsuitable material removed as part of the contract will be paid based upon actual scale tickets for each ton of material removed. Removals will only be allowed based upon individual location approval by the Owner or his authorized representative.
- E. The Contractor will be required to provide any necessary survey controls in order to complete the project in accordance with these requirements.
- F. The Contractor shall maintain at least one driving lane, at all times during all work.
- G. Notification will be provided at least one week in advance of the work to all homes which will be directly impacted by the work.
- H. The Contractor shall provide all necessary and appropriate traffic control signage and flaggers for the proper completion of the work in accordance with the MUTCD.

## PRICE AND PAYMENT

### 32.13.13.15 METHOD OF MEASUREMENT

- A. General
  - 1. Measurement shall include only the work that was installed/performed and accepted.
  - 2. Quantities shall be determined by physical measurement and/or weight tickets, according to the discretion of the Engineer.
- B. Pavement Demolition
  - 1. If this item is included on the bid schedule, payment shall constitute full compensation for removal and disposal of all waste material, including any and all pavement, drainage pans, curbing, base course, subbase, etc. necessary for a complete demolition as described in the Drawings.
- C. Base Course Installation
  - 1. If this item is included on the bid schedule, measurement of aggregate base course and/or subbase shall be to the nearest 0.1 ton based upon scale tickets.
- D. Portland Cement Concrete Pavement, Shoulders, and Misc. Pavement
  - 1. If these items are included on the bid schedule, they will be measured to the nearest 0.1 square yard.
  - 2. Pavement which is removed or for which no payment will be made, will not be measured.
  - 3. When an item for miscellaneous concrete pavement is provided in the contract, the areas of concrete pavement to be measured under this item will be described on the plans.
- E. Dowel Bar Assemblies
  - 1. If this item is included on the bid schedule, it will be measured by the actual number of bars furnished and installed.
- F. Insert Steel Bar in Concrete Pavement
  - 1. If this item is included on the bid schedule, it will be measured by the actual number of bars furnished and installed.
- G. Saw and Seal Joints
  - 1. If this item is included on the bid schedule, it will be measured to the nearest foot.
  - 2. The areas that have spall repairs will not be measured.
- H. Repair of Type A Spalls
  - 1. If this item is included on the bid schedule, it will be measured to the nearest 0.1 square foot.
  - 2. Surface measurements will be taken to the nearest 0.1 foot.
- I. Repair of Type B Spalls
  - 1. If this item is included on the bid schedule, it will be measured to the nearest 0.1 square foot.
  - 2. Surface measurements will be taken to the nearest 0.1 foot.



### 32.13.13.16 BASIS OF PAYMENT

#### A. General

1. Payment shall be made only for work that was accepted.
2. Payment shall constitute full compensation for all work elements, including traffic control and safety provisions, necessary to complete the work in accordance with these requirements.

#### B. Pavement Demolition

1. If this item is included on the bid schedule, payment shall constitute full compensation for removal and disposal of all waste material, including any and all pavement, drainage pans, curbing, base course, subbase, etc. necessary for a complete demolition as described in the Drawings.
2. If it is not on the bid schedule but pavement demolition is required, it shall be considered incidental to the bid schedule work requiring it.

#### C. Base Course Installation

1. If this item is included on the bid schedule, payment for installation of aggregate base course and/or subbase shall be at the contract unit price per ton.
2. Placement shall constitute full compensation for loading, delivery, offloading, site preparation, and placement.
3. If it is not on the bid schedule but subbase or aggregate base course installation is required, it shall be considered incidental to the bid schedule work requiring it.

#### D. Portland Cement Concrete Pavement, Shoulders, and Misc. Pavement

1. These items will be paid for at the contract unit price per square yard.
2. Payment will be full compensation for furnishing all materials (including reinforcing steel), labor, equipment, and all incidentals necessary.
3. Payment will also be full compensation for trimming and water used to moisten the subgrade ahead of the paver, curing the concrete, sawing, and sealing joints and all costs involved in the furnishing, operating, and calibration of the profilograph.
4. The amount bid on these items shall be based on the specified amount of cement per cubic yard. If a cement factor is not shown on the plans, the amount bid shall be based on 600 pounds per cubic yard for pavement, shoulders, and miscellaneous.

#### E. Dowel Bar Assemblies

1. If this item is included on the bid schedule, dowel bar assemblies will be paid for at the contract unit price per each dowel bar.
2. Payment will be full compensation for labor, materials, equipment, and all incidentals necessary to furnish and install the assemblies.
3. If it is not on the bid schedule but bars (steel reinforcement) are required, it shall be considered incidental to the bid schedule work requiring them.

#### F. Insert Steel Bar in Concrete Pavement

1. If this item is included on the bid schedule, dowel bar assemblies will be paid for at the contract unit price per each dowel bar.
2. Payment will be full compensation for labor, materials, equipment, and all incidentals necessary to furnish and install the steel bar.

3. If it is not on the bid schedule but inserted steel bars (doweled steel reinforcement) are required, it shall be considered incidental to the bid schedule work requiring them.

G. Saw and Seal Joints

1. If this item is included on the bid schedule, saw and seal joints will be paid for at the contract unit price per foot.
2. Payment will be full compensation for removal of old sealant, cleaning, and resealing the joints.
3. If it is not on the bid schedule but sawing and sealing joints is required, it shall be considered incidental to the bid schedule work requiring them.

H. Repair of Type A Spalls

1. If this item is included on the bid schedule, repair of type A spalls will be paid for at the contract unit price per square foot.
2. Payment will be full compensation for sawing, sealing, materials, labor, equipment, and incidentals required.
3. If it is not on the bid schedule but repair of type A spalls is required, it shall be considered incidental to the bid schedule work requiring it.

I. Repair of Type B Spalls

1. If this item is included on the bid schedule, repair of Type B spalls will be paid for at the contract unit price per foot or to the nearest square foot, as shown on the plans.
2. Payment will be full compensation for sawing, sealing, materials, labor, equipment, and all incidentals required.
3. If it is not on the bid schedule but repair of type A spalls is required, it shall be considered incidental to the bid schedule work requiring it.

**END OF SECTION**

## **SECTION 32.16.13 – CONCRETE CURB AND GUTTER**

### **GENERAL**

#### **32.16.13.01 SUMMARY**

- A. This work consists of constructing concrete curb and gutter on a prepared subgrade.

#### **32.16.13.02 RELATED WORK**

- A. Section 03.05.13 – Concrete
- B. Section 03.11.13 – Concrete Formwork
- C. Section 32.12.16 – Asphaltic Paving
- D. Section 32.13.13 – Concrete Paving
- E. Section 32.16.15 – Drainage Pan and Fillet
- F. Section 32.91.19 – Topsoiling, Seeding, Fertilizing, and Mulching
- G. Section 32.06.10 – Concrete Sidewalk, Handicap Ramps and Detectable/Tactile Warning Surfaces

#### **32.16.13.03 SUBMITTALS**

- A. Concrete Mix.

### **PRODUCTS**

#### **32.16.13.04 CONCRETE PRODUCTS**

- A. Concrete, expansion joint filler, curing compound, reinforcing steel, and any other related products shall conform to the requirements of section 03.05.13.

### **EXECUTION**

#### **32.16.13.05 GENERAL**

- A. The construction of fillets and curb and gutter shall follow the construction of drop inlet boxes and precede the construction of bituminous surfacing. Drop inlet tops shall be constructed with the curb and gutter to provide a continuous grade and alignment.
- B. Monolithic curb, gutter, and pavement may be placed providing a sawed longitudinal joint is constructed at the theoretical edge of the pavement and the gutter cross slope is as shown for standard curb and gutter.

#### 32.16.13.06 FOUNDATION

- A. The foundation shall be excavated, shaped, and compacted to a firm, uniform bearing surface, conforming to the planned section and established grade.
- B. Unsuitable foundation material shall be removed and replaced as directed.
- C. Granular material, shall be furnished, placed and compacted to the required Contract depth and density. Minimum depth of granular material placed under fillets, pans, curb and gutter, type "P" gutter, and driveway approach pavement shall be four (4) inches.
- D. The foundation shall be thoroughly moistened immediately prior to the placing of concrete.

#### 32.16.13.07 FORMS

- A. Forms shall be full depth, rigid, unyielding and mortar tight. They shall be securely staked, braced, and tied to the required line and grade.
- B. In lieu of construction using fixed side forms, concrete may be placed and formed to the required shape by using an approved type of extrusion machine. When machine placement is used, the Engineer may permit modification of consistency requirements.

#### 32.16.13.08 FINISHING

- A. The exposed surfaces of the fillets and pan and curb and gutter shall be finished smooth and even.
- B. Edges of gutter and the top face edges of the curb shall be finished with an approved finishing tool.
- C. The top surface of the concrete shall be brushed or broomed to slightly roughen the surface and remove the finishing tool marks.
- D. All honeycombed surfaces shall be corrected to the satisfaction of the Engineer by using a grout composed of one part cement and two parts sand. Severely honeycombed areas shall be removed and replaced at the Contractor's expense.

#### 32.16.13.09 JOINTS

- A. Joints shall be constructed at the locations and of the dimensions shown on the plans or as directed by the Engineer.
- B. As a minimum, joints shall match those in the Portland cement concrete pavement section as applicable.
- C. Concrete shall be protected and cured in accordance with the provisions of section 03.05.13.

#### 32.16.13.10 COMPLETION

- A. After the curing period, the area behind the curb and gutter and fillets shall be filled to the required elevations with suitable material and the material shall be satisfactorily compacted. Injury to the concrete shall not occur during these operations.
- B. Curb and gutter and fillets shall be backfilled and compacted prior to placing pavement section if applicable.

#### 32.16.13.11 TESTING

- A. The Contractor shall be responsible for providing a minimum of a slump, air content, seven (7) day and twenty-eight (28) day compressive strength quality test set for each day's pour.
- B. Additional test sets and testing may be required by the Engineer or as called for in the specifications.

### PRICE AND PAYMENT

#### 32.16.13.12 METHOD OF MEASUREMENT

- A. Concrete curb, gutter and combined curb and gutter will be measured to the nearest one-tenth (0.1) linear foot. Measurement for concrete curb will be on the inside bottom face of the curb. Measurement for separate gutters and combined curb and gutter will be on the inside edge next to the pavement.
- B. Measurement of curb and combined curb and gutter will include tapers for approaches and or entrances. Measurement for approach gutter or "P" gutter will not include tapers.
- C. Measurement for curb and gutter shall not include the "gutter throat" of a Type "E" Inlet or the fillet curb. Refer to standard detail.
- D. Concrete fillets, pans, approach pavement and similar items shall be measured to the nearest whole square foot or square yard consistent with the appropriate bid item in the Bidder's Proposal.

#### 32.16.13.13 BASIS OF PAYMENT

- A. Concrete curb, gutter and combined curb and gutter will be paid for at the contract unit prices per linear foot for the types constructed.
- B. Concrete fillets, pans, approach pavement and similar items will be paid for at the contract unit prices per square foot or per square yard for the types constructed.
- C. Payment for granular materials placed under the concrete shall be considered incidental to the payment for concrete curb and gutter.

- D. Payment for these items will be full compensation for furnishing materials, the expansion joints, steel reinforcement, forms, bracing, excavation, backfill, labor, equipment, and incidentals necessary.

**END OF SECTION**

## SECTION 32.16.15 – DRAINAGE PAN AND FILLET

### GENERAL

#### 32.16.15.01 SUMMARY

- A. This section includes the installation of drainage pans within asphalt or concrete street sections.

#### 32.16.15.02 RELATED WORK

- A. Section 03.05.13 – Concrete
- B. Section 03.11.13 – Concrete Formwork
- C. Section 32.06.10 – Concrete Sidewalk, Handicap Ramps and Detectable / Tactile Warning Surfaces
- D. Section 32.12.16 – Asphaltic Paving
- E. Section 32.13.13 – Concrete Paving
- F. Section 33.49.13 – Sanitary Sewer Manholes

#### 32.16.15.03 REFERENCES

- A. SDDOT Standard Specifications for Roads and Bridges, most recent edition.
- B. SDDOT Materials Manual SD 202, Method of Test for Sieve Analysis.
- C. AASHTO T 96-02, Resistance to Degradation of Small-Size Coarse Aggregate by Abrasion and Impact in the Los Angeles Machine.

#### 32.16.15.04 SUBMITTALS

- A. Aggregate Subbase, if applicable.
- B. Aggregate Base Course.
- C. Portland Cement Mix.
- D. Steel Dowel Bars.
- E. Concrete Strength Test Results.

#### 32.16.15.05 QUALITY ASSURANCE

- A. The Contractor will furnish certification for all materials designated in the Contract along with the results of all testing performed.

- B. The owner reserves the right to have the concrete and/or any of the component materials independently tested in accordance with the relevant contract requirements. If the testing shows defective workmanship and/or materials payment will be withheld from the Contractor in the amount of the testing as well as the cost of correction for all deficiencies noted.

## **PRODUCTS**

### **32.16.15.06 AGGREGATE SUBBASE**

- A. Aggregate Subbase material shall meet the requirements of “Subbase” aggregate as defined within the most recent edition of the SDDOT Standard Specifications for Roads and Bridges.

### **32.16.15.07 AGGREGATE BASE COURSE**

- A. Aggregate base course material shall meet the requirements of “Aggregate Base Course” as defined within the most recent edition of the SDDOT Standard Specifications for Roads and Bridges.

### **32.16.15.08 ASPHALT CONCRETE**

- A. Aggregate mix components for asphalt concrete shall meet the requirements of section 32.12.16.

### **32.16.15.09 PORTLAND CEMENT CONCRETE**

- A. Aggregate mix components for Portland cement concrete shall meet the requirements of sections 03.05.13 and 32.13.13.

## **EXECUTION**

### **32.16.15.10 GENERAL**

- A. Work shall be completed in accordance with the most recent edition of the SDDOT Standard Specifications for Roads and Bridges.
- B. Fillets shall be constructed in compliance with sections 03.05.13, 03.11.13, and 32.13.13.
- C. Concrete Sidewalk shall be constructed in compliance with sections 03.05.13, 03.11.13 and 32.06.10.
- D. Concrete joint sealer shall be installed in compliance with section 03.05.13.



- E. The Contractor will be required to provide the necessary survey controls or place the new gravel with automated control system equipment which will result in the required finished typical section.
- F. The Contractor will be required to provide all necessary and appropriate traffic control signage and flaggers for the proper completion of the work in accordance with the MUTCD.

#### 32.16.15.11 ROADWAY SURFACE REMOVAL

- A. Roadway surface removal shall conform to the requirements of sections 32.12.16 and 32.13.13.
- B. All demolition work shall be accomplished in such manner as to avoid damage to adjacent roadway, sidewalk, curbing, and/or property.

#### 32.16.15.12 ASPHALT AND CONCRETE PLACEMENT

- A. Asphalt and concrete placement shall be performed in accordance with the manufacturer's recommendations, standard industry practices, or as directed by the Engineer.
- B. Dimensions and finished grade for new concrete drainage pans shall be as shown on the plans or as directed in writing by the Engineer.
- C. Dimensions and finished grade for new concrete fillets shall be as shown on the plans or as directed in writing by the Engineer.
- D. All joints shall be finished in such manner to ensure smooth flow onto and across the drainage pan and exiting the pan smoothly in the desired flow direction.

#### 32.16.15.13 MANHOLE AND VALVE BOX ADJUSTMENTS

- A. Any manholes requiring elevation adjustment by virtue of the work performed shall have the existing rings and covers replaced with new rings, covers, and chimney seals.
- B. Top rings shall be adjusted to match the new finished grade.
- C. All new manhole parts and accessories shall be provided and installed in accordance with the requirements of section 33.49.13.
- D. Water Valve Boxes shall be adjusted to match flush with the finished concrete elevation of the pan of file.

## **PRICE AND PAYMENT**

### **32.16.15.14 METHOD OF MEASUREMENT**

- A. Concrete drainage pans will be measured to the nearest 0.1 linear foot and the area computed to the nearest square foot.
- B. If listed on the bid schedule, roadway surface removal shall be measured to the closest 0.1 ton based on weight tickets from a landfill or rubble disposal site.

### **32.16.15.15 BASIS OF PAYMENT**

- A. General
  - 1. Payment for all items will constitute full compensation for labor, equipment, tools, backfilling, furnishing, preparing, testing, and placing materials and incidentals necessary, including disposal of excavation and discarded materials.
- B. Roadway Surface Removal
  - B. Except if specifically called out on the bid schedule, roadway surface removal and any associated over excavation will normally be incidental to the contract and no additional payment will be provided for this work.
  - C. If specifically called out on the bid schedule, payment shall be made for the actual amount of material disposed of based on units shown on the bid schedule.
- C. Concrete Drainage Pans and Fillets
  - 1. Concrete drainage pans and fillets will be paid for at the contract unit price per square foot for concrete drainage pan which has been installed and accepted.
  - 2. Such payment shall include granular base material and cushion material and any necessary manhole adjustments.

**END OF SECTION**

## SECTION 32.17.23 – PAVEMENT MARKING

### GENERAL

#### 32.17.23.01 SUMMARY

- A. This section covers street striping and City owned parking lot painting around the City of Box Elder.

#### 32.17.23.02 RELATED WORK

- A. Section 32.12.16 – Asphaltic Paving
- B. Section 32.13.13 – Concrete Paving

#### 32.17.23.03 REFERENCES

- A. South Dakota Department of Transportation (SDDOT) Standard Specifications for Roads and Bridges (most recent edition). Applicable section(s) will include Pavement Marking, Traffic Paint, and Glass Beads.
- B. Manual on Uniform Traffic Control Devices (MUTCD)

#### 32.17.23.04 SUBMITTALS

- A. Paint.
- B. Equipment and Process.
- C. Schedule.

#### 32.17.23.05 QUALITY ASSURANCE

- A. If the work requires reflective media, the owner reserves the right to have the pavement markings tested in accordance with standard SDDOT testing methods for retro-reflectivity.

### PRODUCTS

#### 32.17.23.06 TRAFFIC CONTROL DEVICES

- A. All traffic control devices shall conform to the requirements of the MUTCD, SDDOT design guidelines and specifications, City of Box Elder design requirements, and as directed by the Engineer.

#### 32.17.23.07 PAVEMENT MARKING TAPE

- A. Pavement marking tape shall conform to SDDOT specification section 983 - Cold-Applied Thermoplastic Pavement Marking and Legends. Pavement marking tape shall be 3M™ Type 380/381 ES WR grade for all longitudinal and diagonal lines. All transverse lines and pavement messages shall be 3M™ type 420. Other cold plastic tape material may be used, only if preapproved by the Traffic Engineer and are equal to the types specified.

#### 32.17.23.08 PAINT

- A. The markings shall be made with a waterborne pavement marking paint with high grade polymer.
  - 1. The material shall consist of a durable high build, low VOC, fast drying, waterborne traffic paint with 100% acrylic polymer (DOW DT-400 or DOW HD-21A or equivalent) and with any reflective media adhered to the paint.
  - 2. If the work requires reflective media, it shall meet the following requirements:
    - a. The reflective media shall consist of glass beads as well as bonded core reflective elements.
    - b. The bonded core reflective elements shall contain either clear or yellow tinted microcrystalline ceramic beads bonded to the outer surface.
    - c. All microcrystalline ceramic beads bonded to reflective elements shall have a minimum index of refraction of 1.8 when tested using the liquid oil immersion method.
    - d. Retro-reflectivity readings for white marking paint shall have a minimum value of 350 mcd/m squared/lux. Yellow paint shall have a minimum value of 275 mcd/m squared/lux.

### EXECUTION

#### 32.17.23.09 GENERAL

- A. The work areas shall be thoroughly cleaned and dry before any paint is applied. The Contractor shall provide all necessary flaggers and traffic control to insure the newly applied paint has time to dry before traffic is introduced. The dimensions of the new markings shall match those of the existing markings or as specified in the plans.
- B. The waterborne marking paint shall be installed at a rate of 27.8 gallons/mile for 4" solid lines with 5.3 pounds /gallon of glass beads and 2.1 pounds / gallon of composite reflective elements.

#### 32.17.23.10 PAVEMENT MARKING

- A. Permanent pavement marking tape installation shall conform to SDDOT specifications.
- B. Installation of painted pavement markings and beads, when specified, shall meet or exceed current SDDOT specifications.
- C. All pavement marking shall be applied in accordance with the manufacturer's recommendations.
- D. All pavement marking shall carry to the City all standard manufacturers' warranties.

- E. Permanent centerline marking and, on multi-lane sections, permanent lane lines, and stop bars at traffic controls shall be placed prior to opening to traffic any newly paved, roto-milled surfaces, or asphalt surface treatments.
- F. Marking of edge lines are not required prior to opening to traffic.
- G. Permanent markings shall be of the design, size and color specified on the plans or as directed by the Engineer.
- H. Location, color and number shall be as shown on the plans, or, as directed by the Engineer.
- I. The specific type of markings used shall be approved by the Engineer prior to use.
- J. When weather, time-of-year, or the Contractor's operation does not allow the installation of permanent pavement markings, the Contractor shall install temporary markings and remain responsible for the maintenance of temporary pavement markings until such time as the permanent pavement markings are installed.

#### 32.17.23.11 REMOVAL OF PAVEMENT MARKINGS

- A. Traffic stripes and pavement markings not matching current traffic flows, or as designated by the Engineer, shall be completely removed and obliterated.
- B. Existing and temporary markings, which the Engineer determines to be no longer applicable shall be completely removed and obliterated at no expense to the City.
- C. Removal of all conflicting existing and temporary markings shall be completed prior to opening the road to traffic.
- D. Temporary markings shall be removed prior to the installation of replacement permanent pavement markings.
- E. Pavement markings shall be removed by any method that does not damage the surface or texture of the pavement.
- F. Sand or other material deposited on the pavement as a result of removing markings shall be removed as work progresses.
- G. Accumulations of blast media or other material, which might interfere with drainage or might constitute a hazard to traffic, will not be permitted.
- H. Covering the markings is not acceptable.
- I. Where blast cleaning is used for the removal of pavement markings or for removal of objectionable material, and such removal operation is being performed within 10 feet of a lane occupied by the traveling public, the residue, including dust, shall be removed immediately after contact between the blast media and the surface being treated.
- J. Removal shall be by a vacuum attachment operating concurrently with the blast cleaning operation or by other methods approved by the Engineer.

- K. Contractor shall take all necessary precautions to protect the traveling public during the removal operation.
- L. Damage to the pavement or surfacing caused by pavement marking removal shall be repaired at the Contractor's expense by methods acceptable to the Engineer.

## **PRICE AND PAYMENT**

### **32.17.23.12 METHOD OF MEASUREMENT**

- A. Measurement for permanent pavement markings shall be as follows:
  - 1. All line markings (longitudinal or transverse) shall be measured to the nearest linear foot.
  - 2. All messages will be measured on a per each message basis.

### **32.17.23.13 BASIS OF PAYMENT**

- A. Payment will be for the actual quantities furnished and/or installed.
- B. It shall remain the option of the City to determine which combination of furnish/install is used for each item.
- C. Payment for permanent pavement markings will be made at the contract unit price as per the basis of measurement and shall be considered as full compensation for costs incidental thereto.
- D. Payment will be made following acceptance by the City. Prior to acceptance the Contractor shall supply to the City all necessary warranty certifications.
- E. Payment will be full compensation for all labor, equipment, and material for a complete installation as specified.

**END OF SECTION**

## SECTION 32.91.19 – TOPSOILING

### GENERAL

#### 32.91.19.01 SUMMARY

- A. This section covers topsoiling of areas disturbed by construction activities.

#### 32.91.19.02 RELATED WORK

- A. Section 31.11.10 – Site Clearing
- B. Section 31.14.13 – Earthwork
- C. Section 31.23.16 – Excavation, Trenching and Backfill
- D. Section 32.91.21 – Fertilizing
- E. Section 32.92.19 – Seeding
- F. Section 32.92.21 – Mulching

#### 32.91.19.03 REFERENCES

- A. AASHTO (PAR) Soil Classification System
- B. Unified Soil Classification System (USCS)

#### 32.91.19.04 SUBMITTALS

- A. Soil Sample (1 quart – 1 gallon).
- B. Soil Classification (AASHTO for road/street work, USCS for everything else).

#### 32.91.19.05 QUALITY ASSURANCE

- A. The materials and construction methods specified herein are minimum requirements. Where the appropriate state/local codes require more stringent materials or execution methods, they shall apply.
- B. Notify the Engineer of any planned deviation from these specifications before proceeding so any price changes, or quantity adjustments may be made.

## **PRODUCTS**

### 32.91.19.06 TOPSOIL

- A. Topsoil shall be native topsoil from approved source(s).

## **EXECUTION**

### 32.91.19.07 GENERAL

- A. Topsoiling, fertilizing, seeding, and mulching will only be permitted when soil and weather conditions are favorable.
  - 1. Satisfactory periods for planting are between April 1 and June 1, and between August 10 and September 1.
  - 2. Dormant late fall seeding may be completed with approval from the Project Engineer.

### 32.91.19.08 TOPSOILING

- A. After rough grading is complete spread topsoil to a minimum depth of 6 inches over all disturbed areas to receive seeding.
- B. Remove foreign matter including weeds, grubbed material, wood, metal, or stones over 1 inch in any dimension.
- C. Till soil to a depth of approximately 2 inches, but do not exceed 3 inches.
- D. Remove surface irregularities within the area to be seeded by blading or by other suitable method.
- E. The final surface of the prepared seedbed shall be smooth.

## **PRICE AND PAYMENT**

### 32.91.19.09 METHOD OF MEASUREMENT

- A. Topsoiling
  - 1. If listed on the bid schedule, topsoiling shall be measured to the nearest one-tenth (0.1) cubic yard.

### 32.91.19.10 BASIS OF PAYMENT

- A. General
  - 1. If listed on the bid schedule, payment for topsoiling will be made at the contract unit price as per the basis of measurement and shall be considered as full compensation for costs incidental thereto.
  - 2. If not listed on the bid schedule, topsoiling shall be considered incidental to the project.

**END OF SECTION**



## SECTION 32.91.21 – FERTILIZING

### GENERAL

#### 32.91.21.01 SUMMARY

- A. This section covers furnishing and applying fertilizer to areas disturbed by construction activities which are to be seeded or sodded.

#### 32.91.21.02 RELATED WORK

- A. Section 31.11.10 – Site Clearing
- B. Section 31.14.13 – Earthwork
- C. Section 31.23.16 – Excavation, Trenching and Backfill
- D. Section 32.91.19 – Topsoiling
- E. Section 32.92.19 – Seeding
- F. Section 32.92.21 – Mulching
- G. Section 32.92.23 – Sodding

#### 32.91.21.03 REFERENCES

- A. SDCL 38-19 – South Dakota Commercial Fertilizer Law
- B. ARSD 12:44:05 – South Dakota Bulk Commercial Fertilizer Storage Rules

#### 32.91.21.04 SUBMITTALS

- A. A certified statement from the fertilizer manufacturer stating that the fertilizer is registered for sale in South Dakota and complies with the South Dakota Fertilizer Law.
- B. Fertilizer Data:
  1. The net weight of each fertilizer container.
  2. The name and address of the manufacturer.
  3. The brand and grade.
  4. The guaranteed analysis of the contents (percentage by weight of total nitrogen, available phosphate, and water-soluble potash).

#### 32.91.21.05 QUALITY ASSURANCE

- A. The materials and construction methods specified herein are minimum requirements. Where the appropriate state/local codes require more stringent materials or execution methods, they shall apply.

- B. Notify the Engineer of any planned deviation from these specifications before proceeding so any price changes, or quantity adjustments may be made.

## **PRODUCTS**

### **32.91.21.06 FERTILIZER**

- A. All fertilizers shall
  - 1. conform to applicable State and Federal laws,
  - 2. be packaged in suitable containers,
  - 3. be in a condition, which will permit proper distribution,
  - 4. be labeled with manufacturer's guaranteed analysis,
  - 5. be dry and free from lumps, and
  - 6. contain nutrients in the following proportions:
    - a. Plant available nitrogen: 18 pounds per acre
    - b. Plant available phosphate: 46 pounds per acre
    - c. Plant available potash: 0 pounds per acre

## **EXECUTION**

### **32.91.21.07 GENERAL**

- A. Fertilizer and fertilizer application and storage shall all be in accordance with South Dakota codified laws and administrative rules (see REFERENCES above).
- B. Fertilizing, seeding, and mulching will only be permitted when soil and weather conditions are favorable.
  - 1. Satisfactory periods for planting are between April 1 and June 1, and between August 10 and September 1.
  - 2. Dormant late fall seeding may be completed with approval from the Project Engineer.

### **32.91.21.08 FERTILIZING**

- A. Apply fertilizer uniformly at a rate of 200 pounds/acre using mechanical spreading equipment.
- B. Fertilizer shall be applied not more than forty-eight (48) hours prior to seeding or sodding, unless otherwise approved by the Engineer.
- C. Fertilizer shall be applied by one of the following methods:
  - 1. With a fertilizer attachment on the drill, which will place the fertilizer in a band on or near the drill row behind the openers during the drilling operations (preferred method)?
  - 2. By drilling in with an approved drill prior to seeding.
  - 3. By spreading the fertilizer uniformly over the areas to be seeded prior to or during seedbed preparation (before final pass). This method will not be acceptable when seedbed preparation is not required.

4. Where the seed is sown by a hydraulic seeder, the required amount of fertilizer may be placed in the tank, mixed together with the water and the seed, and applied in the seeding operation.
  5. Incorporate fertilizer into the seedbed by harrowing.
  6. Where required on areas to be sodded, thoroughly mix fertilizer into the top 1 to 2 inches of soil prior to laying sod.
  7. On slopes steeper than 3:1, where fertilizer cannot be incorporated into the soil effectively by mechanized equipment, fertilizer may be applied by any approved method and raked into a depth of approximately 1 inch.
- D. Clods and stones having a vertical projection of 2 inches or more above the soil surface and other foreign materials brought to the surface shall be removed.
- E. The Contractor shall, prior to acceptance of the project, re-fertilize any area on which the original fertilizer has been lost or displaced, as determined by the Engineer.

## **PRICE AND PAYMENT**

### **32.91.21.09 METHOD OF MEASUREMENT**

- A. Fertilizing, seeding, and mulching will be measured to the nearest square yard.

### **32.91.21.10 BASIS OF PAYMENT**

- A. Payment for fertilizing, seeding, and mulching will all be included under the same bid item.
- B. Fertilizing, seeding, and mulching will be paid for at the contract unit price per square yard. This price shall be full compensation for furnishing, hauling, placing, incorporating fertilizer into the work, labor, equipment, materials, tools, and incidentals necessary.

**END OF SECTION**

## SECTION 32.92.19 – SEEDING

### GENERAL

#### 32.92.19.01 SUMMARY

- C. This section covers seeding of areas disturbed by construction activities.

#### 32.92.19.02 RELATED WORK

- A. Section 31.11.10 – Site Clearing
- B. Section 31.14.13 – Earthwork
- C. Section 31.23.16 – Excavation, Trenching and Backfill
- D. Section 32.91.19 – Topsoiling
- E. Section 32.91.21 – Fertilizing
- F. Section 32.92.21 – Mulching

#### 32.92.19.03 REFERENCES

- A. SDCL 38-12A – South Dakota Seed Law

#### 32.92.19.04 SUBMITTALS

- D. Seed mixture:
  - 1. Seed mixes for seeding areas over two acres shall be designed to meet site specific requirements, such as soil type, orientation, slope, irrigation/no-irrigation, soil nutrients, and other. The Contractor shall submit a seed mix listing the specific varieties of seed in the mix intended for use.

#### 32.92.19.05 QUALITY ASSURANCE

- A. The materials and construction methods specified herein are minimum requirements. Where the appropriate state/local codes require more stringent materials or execution methods, they shall apply.
- B. Notify the Engineer of any planned deviation from these specifications before proceeding so any price changes, or quantity adjustments may be made.

## PRODUCTS

### 32.92.19.06 SEED

#### A. General:

1. The seed furnished shall be the best quality seed available for the kind and variety specified.
2. The seed shall comply with the requirements of the South Dakota Seed Law and shall be "Blue Tag" certified governed by Federal Regulations.

#### B. Origin Limitations:

1. Seed furnished shall have been grown in South Dakota or an area comparable to South Dakota's growing conditions.

#### C. Seed Testing:

1. Seed shall be tested within 18 months prior to the planting date.
2. Testing shall be performed by a commercial seed testing lab or a registered member of the Society of Commercial Seed Analysts (Registered Seed Technologist).
3. The Contractor shall furnish the Engineer with a certified test report prior to the start of seeding operations.
4. Seed not planted within the 18-month period shall be retested for dormant seed, hard seed, and germination and a new certified test report shall be furnished.
5. Testing shall be the sole responsibility of the Contractor.

#### D. Labeling:

1. Before seeding begins, the Engineer shall verify that each bag of seed delivered to the project bears a tag, which shows the following information:
  - Name and address of supplier.
  - Project number for which the seed is to be used.
  - Suppliers lot number for each kind of seed in the mixture.
  - Origin (where grown) for each kind of seed.
  - Purity, germination, and other information required by South Dakota Seed Law for each kind of seed.
  - Pounds of bulk seed of each kind of seed in each bag.
  - Total pounds of bulk seed mixture in each bag.
  - Pounds of pure live seed (PLS) of each kind of seed in each bag.
  - Total pounds of pure live seed (PLS) mixture in each bag.
  - Dormant seed and hard seed.
2. When bulk seed is referred to, it is defined as total seed, including pure live seed (PLS), inert matter, crop seed, and weed seed.

#### E. Seed Mixes:

1. Seed mixes for small applications, under two acres, may be the following:
  - a. Irrigated Lawn mix:
    - i. 80% of at least 3 varieties of Kentucky Bluegrass
    - ii. 20% Perennial Ryegrass
    - iii. Rate of application – 175# per acre
  - b. Non-irrigated Lawn mix:
    - i. 20% Blue Fescue
    - ii. 20% Chewings Fescue

- iii. 20% Creeping Red Fescue
- iv. 20% Hard Fescue
- v. 10% Perennial Ryegrass
- vi. 10% NuBlue Kentucky Bluegrass
- vii. Rate of application – 200# per acre
- viii.
- c. Road Ditch mix:
  - i. 40% Crested Wheatgrass
  - ii. 30% Perennial Ryegrass
  - iii. 20% Hard Fescue
  - iv. 10% Annual Ryegrass
  - v. Rate of application – 100# per acre

## EXECUTION

### 32.92.19.07 GENERAL

- A. Within seasonal limitations, seeding shall be done as soon as finish grading and topsoiling have been completed.
- B. The topsoil to be used in the areas to be seeded or hydroseeded shall have a minimum depth of 6 inches.
- C. Seeding will only be permitted when soil and weather conditions are favorable.
  - 1. Satisfactory periods for planting are between April 1 and June 1, and between August 10 and September 1.
  - 2. Dormant late fall seeding may be completed with approval from the Project Engineer.
  - 3. The condition of the soil shall permit preparation of a satisfactory seedbed.
  - 4. Seeding shall not be done when the ground is frozen.
  - 5. Seed shall not be sown on areas under water.
  - 6. Seed shall not be sown when the wind is strong enough to interfere with uniform seed application.
  - 7. Slopes shall be worked longitudinally, on contour, during the preparation of areas, drilling, and after seeding.
- D. The Contractor shall calibrate the drill or hydro seeder on each project. Calibration runs may be performed on areas to be seeded.
- E. Seeding shall not be done without authorization from the Engineer.
  - 1. The Engineer may approve necessary adjustment in the requirements outlined to obtain the most satisfactory results under varying conditions.

### 32.92.19.08 SEEDING

- A. Seedbed Preparation:
  - 1. Initial preparation of newly graded areas for seeding shall be worked to a minimum depth of 6 inches.
  - 2. Every effort shall be made to obtain the 6-inch depth on the first pass with tillage equipment.

3. The implement used shall be a tool carrier with rigid shanks and sweeps or chisels or a heavy-duty disk as appropriate to the conditions.
  4. The implement shall have positive means of controlling depth of penetration.
  5. Lumps or clods exposed by the initial pass of tillage equipment over 3 inches in diameter shall be broken up.
  6. The number of additional passes required breaking up lumps or clods shall be kept to a minimum.
  7. Working the soil to a fine, pulverized condition shall be avoided.
  8. After seedbed preparation has been completed, the Contractor shall pick up and dispose of all loose stones or boulders having a vertical projection of 2 inches or more above the soil surface.
  9. Logs, stumps, brush, weeds, cables, or other foreign material, which might interfere with the proper operation of drills, mowers, or other implements, shall be disposed of by the Contractor.
- B. Sow seed within 48 hours of completion of seedbed preparation.
- C. Sow with mechanical seeding equipment that will provide uniform distribution at the specified rate of 18 pounds per acre.
- i. Seeders shall have agitators to provide continuous mixing of seed.
  - ii. Grain drills may be used only if equipped with seed attachments.
  - iii. Operate all mechanical equipment to eliminate the effect of distinct rows of seeding.
- D. Seed shall be covered with topsoil to a depth of ¼ inch.
- E. Compact soil by rolling.
- i. Seed shall be firmly embedded.
  - ii. Rolling shall be done along the contours, at right angles to existing slopes.
- F. Reseeding of Previously Seeded Areas:
1. Existing weeds and cover crop shall be preserved for its mulch value.
  2. The seed shall be drilled directly into existing cover, if possible, or mowing and disking shall be provided to permit penetration of drill openers and placement of seed to the specified depth.

### 32.92.19.09 DRILLING

- A. Process:
1. The specified seed mixture shall be drilled in uniformly, using a press drill equipped with individually mounted, adjustable, spring-loaded, double-disk furrow openers, fitting with depth control bands or drums.
  2. The depth control bands or drums shall provide a loose planting depth of 1 - 1 ½ inches (distance from band to edge of opener disk) before compaction by the press wheel and a final planting depth of ¾ – 1 inch behind the press wheel.
  3. The press drill shall be mounted on rear press wheels, which carry a major portion of the weight of the drill and having no weight carrying wheels at the ends of the seed box.
  4. The press wheels shall be mounted independently of the furrow openers.
  5. A press wheel shall follow directly behind each opener to compact the soil over the drill row.

6. The seed box shall be equipped with positive feed mechanisms, which will accurately meter the seed to be planted, and agitators which will prevent bridging in the seed box and keep seeds uniformly mixed during drilling.
7. The drill shall conform to the following:
  - a. Drill Width Maximums:
    - i. Single Units.....10 feet
    - ii. Flex coupled side-by-side units .....16 feet  
(max. two 8-foot members)
8. Each drill shall be equipped with a meter, which will measure the area covered by the drill.
9. Each drill shall be equipped with fabricated baffles or partitions mounted a maximum of 2 feet on centers and flush with the top of the seed box and extending downward to within 4 inches of the bottom of the seed box.
10. On areas where a press drill cannot be operated satisfactorily, hydraulic, cyclone, knapsack hand-operated, or other broadcast type seeders may be used, when approved by the Engineer.

### 32.92.19.10 HYDROSEEDING

#### A. General:

1. Drilling is the preferred method of seeding.
2. If the Contractor desires to use hydroseeding a submittal shall be provided to the engineer for approval.
3. The submittal shall include the name of the subcontractor intended to perform the work, details on the required site preparation, proposed slurry mix, and the recommended environmental conditions for application.

#### B. Process:

1. The specified seed mixture shall be hydro seeded uniformly, using a hydro seeder.
2. The hydro seeder shall be equipped with a gear-driven pump and a paddle agitator.
3. Agitation by re-circulation from the pump will not be allowed.
4. Agitation shall be sufficient to produce homogeneous slurry of seed and fertilizer in the designated proportions.
5. Fertilizer of the specified formulation shall be included at the specified rate.
6. Specified seed mixtures shall be included at the specified rate.
7. No seed shall be added to the slurry until immediately prior to beginning the seeding operation.
8. Legume seed shall be pellet inoculated with the appropriate bacteria.
9. Inoculation rates shall be four times that required for dry seeding.
10. The time allowed between placement of seed in the hydro seeder and emptying of the hydro seeder tank shall not exceed 30 minutes.
11. Wood cellulose fiber mulch shall be degradable, wood cellulose fiber or 100% recycled long-fiber pulp, free from weeds or other foreign matter toxic to seed germination and suitable for hydro mulching.

### 32.92.19.11 COMPLETION REQUIREMENTS

#### A. Care During Construction and Final Inspection:

1. The Contractor is responsible for smoothing dirt ridges, which result from his operations or from traffic.
2. Such ridges shall be smoothed so they will not interfere with future mowing.



3. Following completion of seeding operations, foot, vehicular, or equipment traffic over the seeded area shall be kept to a minimum.
4. Areas damaged from such traffic shall be reworked and reseeded as determined by the Engineer.
5. The Contractor shall, prior to acceptance of the project, reseed any area on which the original seed has been lost or displaced.

**B. Watering:**

1. After seed, fertilizer and mulch have been placed, it shall be watered to provide a moist condition through the mulch as well as into the underlying soil bed.
2. For a period of three weeks after seeding and initial watering, the Contractor shall apply adequate water to insure proper germination of the seed and growth of the grass.
3. The Engineer may waive watering requirements if adequate natural moisture has been present.
4. At the end of the 3-week watering period, the Engineer will make an inspection to determine if the grass is alive and growing.
5. If seed has not satisfactorily rooted into the soil and is not alive and growing, the Engineer will determine if new seed and/or additional watering, at the Contractors expense, are required.
6. Replaced seed shall be watered as required for the original.
7. After the Engineer's acceptance of the newly seeded areas, the Contractor shall notify all affected property owners, with notification of watering requirements provided by the Owner, that they will be responsible for watering the newly seeded areas.
8. The Contractor shall provide written verification that affected property owners have both been notified and have accepted the condition of the newly seeded areas.
9. The growing season is defined as May through September.

## **PRICE AND PAYMENT**

### **32.92.19.12 METHOD OF MEASUREMENT**

- A. Fertilizing, seeding, and mulching will be measured to the nearest square yard.
- B. Documentation of the application rate and amount shall be furnished to the Engineer to verify the area.

### **32.92.19.13 BASIS OF PAYMENT**

- A. Fertilizing, seeding, and mulching will be paid for at the contract unit price per square yard. This price will be full compensation for the preparation of the seed and for labor, tools, equipment, and incidentals necessary.
- B. Payment for fertilizing, seeding, and mulching will all be included under the same bid item.
- C. Water for seeding shall be considered incidental and shall be included in the unit price bid for seeding.

**END OF SECTION**

## SECTION 32.92.21 – MULCHING

### GENERAL

#### 32.92.21.01 SUMMARY

- A. This section covers placement of mulch cover on designated areas following seeding operations.

#### 32.92.21.02 RELATED WORK

- A. Section 31.11.10 – Site Clearing
- B. Section 31.14.13 – Earthwork
- C. Section 31.23.16 – Excavation, Trenching and Backfill
- D. Section 32.91.19 – Topsoiling
- E. Section 32.91.21 – Fertilizing
- F. Section 32.92.19 – Seeding

#### 32.92.21.03 REFERENCES

- A. SDCL 38-19A – South Dakota Soil Amendment Law

#### 32.92.21.04 SUBMITTALS

- A. A certified statement from the fertilizer manufacturer stating that the fertilizer is registered for sale in South Dakota and complies with the South Dakota Fertilizer Law.
- B. Mulch Data.

#### 32.92.21.05 QUALITY ASSURANCE

- A. The materials and construction methods specified herein are minimum requirements. Where the appropriate state/local codes require more stringent materials or execution methods, they shall apply.
- B. Notify the Engineer of any planned deviation from these specifications before proceeding so any price changes, or quantity adjustments may be made.

### PRODUCTS

#### 32.92.21.06 GENERAL

- A. Grass Hay or Straw Mulch:
1. Grass hay or straw mulching shall be substantially free of noxious weed seeds and objectionable foreign matter.
  2. The mulch shall have been baled dry, in bales of approximately equal weight and shall be relatively dry when applied.
  3. The Engineer can reject materials having characteristics which, in the opinion of the Engineer, makes them unsuitable for the purpose intended.
  4. Bromegrass is not an acceptable mulch.
- B. Fiber Mulch:
1. Fiber Mulching shall contain no germination or growth inhibiting factors and shall have the property of becoming evenly dispersed and suspended when agitated in water.
  2. When sprayed uniformly on the surface of the soil, the fibers shall form a blotter-like ground cover, which will readily absorb water and allow infiltration to the underlying soil without restricting emergence of seedlings.
  3. Weight specification from suppliers, and for all applications, shall refer only to air dry weight of the fiber, considered to be 10 percent moisture.
  4. The fiber mulch material shall be supplied in packages marked by the manufacturer to show the air-dry weight content.
  5. Suppliers shall certify that laboratory and field testing of their product has been accomplished and that it meets all of the foregoing requirements.
- C. Compost and Wood Chip Mulch:
1. Compost shall be  $\frac{3}{4}$  inch minus and  $\frac{3}{8}$  inch minus screened material.
  2. Wood Chip Mulch shall be material passing the  $\frac{3}{4}$  inch screen.
  3. No chemical additives shall be added during the composting process.
  4. The process shall be completely natural utilizing the organic feedstock, water and air.
  5. The material shall be composted to a ratio of 30 parts carbon to 1 part nitrogen before screening the material.
  6. The compost shall be registered through the South Dakota Department of Agriculture as a soil amendment.
- D. Hydroseeding Tackifier Amendment:
1. Hydro seeding tackifier amendment shall be a safe, non-toxic polymer that can be used with any paper or fiber mulch products.
  2. The anionic high molecular weight polymer binds the hydroseeding media to the soil particles.
  3. The tackifier shall be hydrophobic and allow water into the mulch matrix.
  4. The tackifier shall be a synthetic material that is free of weed seed and any organic containments.
  5. It shall be compatible with biostimulants, fertilizers and surfactants.
  6. It shall not clump in the tank and clog the spray nozzle.
  7. The tackifier lubricates the slurry mix and tightens the slurry stream and will increase the shooting distance.
  8. The tackifier will break down from UV light in 5-6 weeks.
  9. The tackifier can be used as a temporary dust abatement in non-traffic areas.
  10. The tackifier can be applied as a temporary soil stabilizer to protect against erosion.
  11. The tackifier can be applied through hydraulic equipment for clarifying sediment/holding ponds.

## EXECUTION

### 32.92.21.07 GENERAL

- A. Mulch shall be in accordance with South Dakota codified laws and administrative rules (see REFERENCES above).
- B. Fertilizing, seeding, and mulching will only be permitted when soil and weather conditions are favorable.
  - 1. Satisfactory periods for planting are between April 1 and June 1, and between August 10 and September 1.
  - 2. Dormant late fall seeding may be completed with approval from the Project Engineer.

### 32.92.21.08 MULCHING

- A. Grass Hay or Straw Mulch:
  - 1. Place mulch within 48 hours of seeding.
  - 2. Mulch all seeded areas including the top surfaces of embankments, ditches, and all cut and fill slopes 6:1 or steeper.
  - 3. The Engineer may vary application rates to provide a more stable mulch cover, to prevent erosion, and/or to encourage turf establishment.
  - 4. Blow mulch uniformly at a rate of 4000 pounds of mulch per acre.
    - a. Use a mulch blower designed for the purpose.
    - b. Break straw bales before feeding into blower.
    - c. Mulch containing excessive moisture, which prevents uniform feeding through the machine, shall not be used.
    - d. Mulch shall be placed uniformly over the seeded areas.
  - 5. Mulching operations shall not be performed during periods of high winds, which preclude the proper placing of the mulch.
  - 6. The placing of mulch shall begin on the windward side of the areas to be covered.
  - 7. Allow approximately 10% of the soil surface to be visible through the mulch blanket.
  - 8. Mulch blanket following placement should be approximately 1-inch thick.
  - 9. Avoid excessive mulch cover which will smother seedlings.
  - 10. The Engineer may order the placement of mulch on any area where protection is considered necessary to forestall erosion or encourage turf establishment.
- B. Punching:
  - 1. Punch mulch into soil immediately after application using a mulch tiller having:
    - a. A series of dull flat disks with notched or cutout edges.
    - b. Disks 20 inches in diameter and ¼-inch thick.
    - c. Disks spaced approximately 8 inches apart and fitted with scrapers.
    - d. The total working width of the tiller shall not exceed 10 feet (unless provided with flexible sections that will follow the ground contour).
    - e. Ballast tiller members as necessary to push straw into the soil approximately 3 inches with the ends of the straw exposed above the soil surface.
  - 2. The mulch tiller shall follow as closely as possible behind the mulch blower.
  - 3. Operate the mulch tiller along the contour.
  - 4. The Engineer may require diagonal operation on slopes of 3:1 or greater, and if necessary, the use of dual drive wheels or crawler treads to minimize damage to the slope.

5. Multiple or diagonal mulch tiller passes may be required to ensure adequate anchoring of the mulch.
6. Prohibit unnecessary foot, equipment, and vehicular traffic over the seeded and mulched areas.

C. Fiber Mulch:

1. Rate of application shall be 2000 lbs. per acre unless otherwise specified by the Engineer.
2. Excessive thickness of mulch, which will smother grass seedlings, shall be avoided.
3. Mulch shall be placed on a given area as soon as possible, or within 48 hours after seeding.

D. Compost:

1. Apply a ¼ inch layer of compost over the seeded area, then water to protect against hot, dry weather or drying winds.

E. Hydroseeding Tackifier Amendment:

1. Hydro seeding:
  - a. When using as a tackifier with paper or fiber mulch, add three pounds per acre.
  - b. Slowly pour the tackifier into the water and thoroughly mix in the tank.
  - c. Add mulch, seed, fertilizer and any other components in the tank and thoroughly mix.
2. Straw Tacking:
  - a. Apply three pounds per acre with 750 pounds of wood or paper mulch.
3. Temporary Dust Control:
  - a. Apply to non-traffic areas at a rate of three pounds per acre with 1000 gallons of water. On slopes of 4:1 to 2:1 apply at a rate of 6-12 pounds per acre.
4. Clarifying Sediment/Holding Ponds:
  - a. Slowly pour two-three pounds of tackifier into 1000 gallons of water while the tank is agitating.
  - b. Thoroughly mix for 15 minutes and spray to one surface acre of water.

F. Care During Construction and Final Acceptance:

1. Traffic – either foot, equipment, or vehicular – shall be kept to a minimum over the seeded and mulched areas.

- G. The Contractor shall, prior to acceptance of the project, re-mulch any area on which the original mulch has been displaced as a result of excessive wind, water, or other causes.

## **PRICE AND PAYMENT**

### **32.92.21.09 METHOD OF MEASUREMENT**

- A. Fertilizing, seeding, and mulching will be measured to the nearest square yard.

### **32.92.21.10 BASIS OF PAYMENT**

- A. Payment for fertilizing, seeding, and mulching will all be included under the same bid item.

- B. Fertilizing, seeding, and mulching will be paid for at the contract unit price per square yard. This price shall be full compensation for furnishing, hauling, placing, incorporating fertilizer into the work, labor, equipment, materials, tools, and incidentals necessary.
- C. Compost and Wood Chip Mulch will be paid for at the contract unit price per ton, which will be full compensation for furnishing, hauling, and placing, and for materials, equipment, labor, tools, and incidentals necessary.
- D. When Hydroseeding Tackifier Amendment is being used for temporary dust control or clarifying sediment/holding ponds the Hydroseeding Tackifier Amendment will be paid for at the contract unit price per acre which will be full compensation for furnishing, hauling, and placing, and for materials, equipment, labor, tools, and incidentals necessary.

**END OF SECTION**

## SECTION 33.05.23 – BORING, JACKING, AND DIRECTIONAL DRILLING

### GENERAL

#### 33.05.23.01 SUMMARY

- A. This section covers boring, jacking, and directional drilling primarily associated with pipeline road and stream crossings. Non-cased directional drilling is included.

#### 33.05.23.02 RELATED WORK

- A. Section 31.23.16 – Excavation, Trenching, and Backfill

#### 33.05.23.03 REFERENCES

- A. ASTM D1785 – Standard Specification for Polyvinyl Chloride (PVC) Plastic Pipe, Schedules 40, 80, and 120
- B. ASTM D2241 – Standard Specification for PVC Pressure-Rated Pipe (SDR Series)
- C. ASTM A53 – Standard Specification for Pipe, Steel, Black and Hot-Dipped, Zinc-Coated, Welded and Seamless
- D. ASTM D3350 – Standard Specification for Polyethylene Plastics Pipe and Fittings Materials

#### 33.05.23.04 SUBMITTALS

- A. PVC casing.
- B. Yelomine casing.
- C. HDPE casing (include maximum allowable bend radius).
- D. Steel pipe casing.
- E. Casing spacers.

#### 33.05.23.05 QUALITY ASSURANCE

- A. The materials and construction methods specified herein are minimum requirements. Where the appropriate state/local codes require more stringent materials or execution methods, they shall apply.
- B. Notify the Project Engineer of any planned deviation from these specifications before proceeding so any price changes, or quantity adjustments may be made.



## PRODUCTS

### 33.05.23.06 PVC CASING

- A. Comply with ASTM D1785.
- B. Minimum wall thickness of Schedule 80 pipe.

### 33.05.23.07 YELOMINE CASING

- A. Comply with ASTM D2241.
- B. Minimum wall thickness of SDR-21 pipe.

### 33.05.23.08 HIGH DENSITY POLYETHYLENE CASING (HDPE)

- A. Manufactured from very high molecular weight pipe resin, designated as PE3408.
- B. Minimum pressure rating of 100 psi.

### 33.05.23.09 STEEL PIPE CASING

- A. Conform to ASTM A53.
- B. Casing 2 inches to 6 inches in diameter:
  - A. Standard weight galvanized steel.
- C. Casing 8 inches in diameter or larger:
  - A. Minimum wall thickness of ¼ inch.
  - B. Grade A.

### 33.05.23.10 CASING SPACERS

- A. Non-metallic, projection type equal to RACI type spacer.

### 33.05.23.11 PIPE END SEALS

- A. Rubber wrap around end seal.
- B. Stainless steel clamps.
- C. Equal to Model W, as manufactured by Pipeline Seal and Insulator, Inc.

## EXECUTION

### 33.05.23.12 GENERAL

- A. No portion of the drill rig shall be within 15 feet of the roadway.
- B. Traffic signage shall comply with the requirements of the highway authority.
- C. When drilling operations are conducted for a stream crossing, protection for the free and safe flow of the waterway is required.
- D. Comply with Storm Water Pollution Prevention Plan.

### 33.05.23.13 BORING AND JACKING

- A. Install casing by boring where indicated on the plans.
  - 1. Comply with the local governing authority for the circular annulus size allowed for the size casing installed.
- A. Maintain depth of cover as indicated on plans.
- B. Use suitable guide rails in the approach pit.
- C. When unstable soil conditions are found to exist, conduct boring operations in a manner that will not be detrimental to facility being crossed.
  
- B. Install the size casing indicated on the plans.
  
- C. Deviation from line and grade of carrier pipe shall not exceed the following limits:
  - 1. Water main, water service lines, and effluent force main:
    - a. Horizontal: 1 foot per 100 feet of main or service line, maximum.
    - b. Vertical: 0.4 feet per 100 feet of main or service line, maximum.
    - c. Maintain a minimum 10-foot bury depth under roadways.
  - 2. Sewer main and sewer service lines.
    - a. 0.2 foot per 100 feet of main or service line.
    - b. Minimum grade as indicated on the plans must be maintained.
  - 3. A means of steering the casing must be provided to ensure allowable tolerance can be achieved.
  - 4. As the boring proceeds, the steel casing pipe must be jacked into place.
  - 5. If the tolerances noted above are not met, the contractor will bear the expenses for any fittings or pipeline corrections to bring the water line back to designed line and grade.
  
- D. Install casing for sewer service lines prior to the installation of any portion of the sewer service line.
  
- E. Install casing for sewer mains prior to the installation of any portion of the main between the manholes to which the pipe will be connected.
  
- F. Install casings for water mains, water service lines, and effluent force mains prior to the installation of pipe within 100 feet of the crossing for the main or service line under construction.

- G. Casing connections shall be as follows:
  - 1. PVC casing.
    - a. Pipe manufacturer restrained joint system approved by the engineer.
  - 2. Yelomine casing.
    - a. Restraint joint couplings utilizing the precision machine grooves on the pipe and a spline.
  - 3. Steel pipe casing.
    - a. Connections shall be full depth circumference welds.
    - b. Welding shall be performed by operator(s) qualified in accordance with the American Welding Society standard procedures.
    - c. All welds shall be continuous, complete joint penetration butt joint welds resulting in rigid and watertight connections.
    - d. The strength of all welds shall be equal to that of the pipe being welded.
- H. Install end seals on casing in accordance with manufacturer's recommendations.
- I. Install casing spacers on the carrier pipe in accordance with the manufacturer's recommendations.
  - 1. Space casing spacers at a span of 6 ½ feet to 10 feet.
    - a. Maximum span length for sewer pipe is 7 feet.
  - 2. Carrier pipe bells shall not contact the casing.

#### 33.05.23.14 DIRECTIONAL DRILLING

- A. Install the size casing indicated on the plans or as necessary for the carrier pipe.
- B. Maintain a drilling log book with the following information:
  - 1. Dates.
  - 2. Times.
  - 3. Locations.
  - 4. Soil conditions.
  - 5. Drilling data.
    - a. Depth.
    - b. Angle.
    - c. Rate of penetration.
  - 6. Utility Crossings.
- C. Utilize a walkover system or wireline steering tool to drill the pilot hole.
  - 1. Record the readings a minimum of every 25 feet.
  - 2. Keep grade alignment within ½ foot of grade indicated on plan.
  - 3. Re-bore sections not meeting this requirement.
  - 4. The exit point shall be accurate within 2 percent of the length of the drill hole.
- D. Ream pilot hole to the smaller of either:
  - 1. 4 inches larger than the outside diameter of the casing pipe being installed or,
  - 2. 1 ½ times the outside diameter of the casing pipe being installed.
- E. Drill mud shall be left in the hole to fill all voids around the pipe.

- F. Install end seals on casing in accordance to manufacturer's recommendations.
- G. The pipe pullback operation shall be carried out as soon as possible following the reaming.
  - 1. When pulling pipe through the hole, steps should be taken to prevent rotational torque from spinning the pipe.
- H. Casing connections.
  - 1. Heat fusion connections in accordance to manufacturer's recommendations.
- I. Provide a drilling log book of drilling operations to the Engineer.
  - 1. The entries shall be typed, with data neatly organized.

#### 33.05.23.15 NON-CASED DIRECTIONAL DRILLING

- A. Install at location and depth as indicated on the plans.
- B. Utilize surface locators during the drilling operation.
- C. The location of the exit point shall be accurate within 2 percent of the length of the drill hole.
- D. Final diameter of the drill hole shall be no greater than 2 inches larger than the pipe installed.
- E. Complete the pipe pullback operation as soon as possible, following the completion of the drill hole.

### PRICE AND PAYMENT

#### 33.05.23.16 BORING AND JACKING

- A. Measurement: By lineal foot of casing installed and material used.
- B. Basis of Payment: Includes all materials, labor, and equipment used for installing the casing, casing spacers, end seals, and other appurtenances required to complete the work as specified.

#### 33.05.23.17 DIRECTIONAL DRILLING

- A. Measurement: By lineal foot of casing installed.
- B. Basis of Payment: Includes all materials, labor, and equipment used for installing the casing, end seals, casing spacers, and other appurtenances required to complete the work as specified.

33.05.23.18 NON-CASED DIRECTIONAL DRILLING

- A. Measurement: By lineal foot of drill hole.
- B. Basis of Payment: Includes all materials, labor, and equipment used for drilling and other appurtenances required to complete the work as specified. The carrier pipe will be paid for separately, as listed on the bid schedule.

**END OF SECTION**

## SECTION 33.05.25 – STATIC PIPE BURSING / SPLITTING

### GENERAL

#### 33.05.25.01 SUMMARY

- A. This section addresses the procedures to be employed for replacement of existing water or sewer pipelines identified on the drawings via pipe bursting or splitting.
- B. Work may include replacement of connections to service lines and piping appurtenances (e.g., valves, manholes, etc.).

#### 33.05.25.02 RELATED WORK

- A. Section 33.11.13 – Potable Water Distribution
- B. Section 33.31.13 – Sanitary Sewer Main
- C. Section 33.31.20 – Sanitary Sewer Main Cleaning and Inspection

#### 33.05.25.03 REFERENCES

- A. ASTM D3350 – Standard Specification for Polyethylene Plastics Pipe and Fittings Materials
- B. ASTM F2619 – Standard Specification for High-Density Polyethylene (PE) Pipe
- C. ASTM F412 – Standard Terminology Relating to Plastic Piping Systems
- D. ASTM F714 – Standard Specification for Polyethylene (PE) Plastic Pipe (DR-PR) Based on Outside Diameter

#### 33.05.25.04 SUBMITTALS

- A. PE Pipe
- B. Proposed process including at minimum:
  - 1. Description of process to be used.
  - 2. Replacement pipe and fitting selection and composition.
  - 3. Recommended manufacturer's installation procedures.
  - 4. ASTM references for process and materials.
  - 5. Layout, storage, and pipe handling area requirements for maintenance of pedestrian and vehicle traffic for each project site.
  - 6. Plan for locating, exposing, and re-connecting service lines, valves, manholes, etc., including any water stops and restraints, as pertinent to the contract.
  - 7. Proposed point repair method to remove or manage sags, offset joints, constrictions, obstructions, and/or other piping issues prior to replacement activities.

8. Bypass pumping plan, if applicable.
9. Emergency plan. A copy of the approved plan shall be maintained on site for the duration of project.
10. Backup equipment plan, if applicable. If working on piping which is in service and will have to be taken out of service, a plan shall be developed which will detail where backup equipment is available and how long it would take to be delivered to project sites.
11. Training certificates for all personnel performing processes requiring training, including joint fusion, if applicable. Include individual's name, date(s) of training, and process(es) for which certified.
12. Design calculations resulting in wall thickness for appropriately sized SDR for each installation section as follows:
  - a. Use soil depth at deepest installation.
  - b. Assume ground water table height of four feet below grade unless ground water monitoring data indicates different height.
  - c. List values of key parameters used in calculations, including but not limited to; density of soil, depth of burial, live loads, safety factors, pipe modulus of elasticity, soil modulus and total calculated pressure on the pipe.
  - d. Documentation of source of equations and methodologies used in calculations.
  - e. Allowable tensile stress during pulling of pipe.
  - f. Calculated pipe deflection versus allowable pipe deflection for selected pipe.
  - g. Critical buckling pressure.
  - h. Slip trench or entry pit dimensions for pipe insertion (as applicable).
13. Post-replacement video inspection report.
14. Complete post-bursting inspection after bursting process, reconnection of laterals and renewals are completed.
15. Pulling log to include Allowable Tensile Load (ATL) and duration of pull of the replacement pipe.
16. All field testing results.

### 33.05.25.05 DEFINITIONS

- A. **Static Pipe Bursting:** Process of fracturing the host main via constant tensile pressure on the bursting head forcing the fragments into the surrounding soil for the purpose of inserting a replacement pipe of equal or larger diameter. Note that a dynamic pipe bursting process will not be allowed.
- B. **Pipe Splitting:** Process of splitting (with blades either mounted on the bursting head or as a separate accessory in front of the bursting head) via constant tensile pressure on the bursting head fracturing the host main via constant tensile pressure on the bursting head forcing the fragments into the surrounding soil for the purpose of inserting a replacement pipe of equal or larger diameter. Note that a dynamic pipe splitting process will not be allowed.
- C. **Host Main:** Existing pipeline which is subject to the pipe bursting process. Pipeline can be manufactured of asbestos cement, polyvinyl chloride (PVC), cast iron, concrete, steel, or lined pipe.
- D. **Replacement Pipe:** Pipe inserted into host sewer main by pipe bursting system.

- E. Continuous Pipe: Pipe, such as high-density polyethylene (HDPE) pipe, with welded joints, assembled and inserted to form continuous sections between access pits.
- F. Sectional Pipe: Pipe, such as HDPE pipe, vitrified clay pipe (VCP), polymer pipe, or PVC pipe assembled using leak proof joints and inserted into host sewer main in sections.
- G. Renew Lateral: Service line in public space or easement to be replaced by pipe bursting or, if necessary, by excavation and replacement.

#### 33.05.25.06 QUALITY ASSURANCE

- A. The materials and construction methods specified herein are minimum requirements. Where the appropriate state/local codes require more stringent materials or execution methods, they shall apply.
- B. The Contractor shall get approval by the Project Engineer of any planned deviation from these specifications before proceeding.
- C. The pipe bursting system shall be commercially proven with a minimum of 500,000 linear feet of successful main line replacement.
- D. The personnel performing pipe bursting shall be certified by the manufacturer of the pipe bursting system and have successfully completed training in:
  - 1. operating the bursting head,
  - 2. installing proposed replacement pipe, and
  - 3. operation and maintenance of all equipment to be used.
- E. The personnel performing fusing of HDPE pipe and fittings shall be certified by the manufacturer of the fusing equipment and have successfully completed training in:
  - 1. handling replacement pipe materials,
  - 2. butt fusion of pipe joints,
  - 3. saddle fusion of fittings for service lines, and
  - 4. operation and maintenance of all equipment to be used.
- F. In addition to the required testing and monitoring activities, the Contractor shall visually inspect the entire setup prior to work commencing on any replacement section as well as all post-replacement work.
- G. Delivery and Storage:
  - 1. Transport, handle, and store pipes and fittings as recommended by manufacturer.
  - 2. Replace pipe or fittings damaged before or during installation at no additional cost to the Commission.

## PRODUCTS

#### 33.05.25.07 HIGH DENSITY POLYETHYLENE (HDPE)

- A. Manufactured from very high molecular weight pipe resin, designated as PE3408 according to ASTM F412 and sized and marked according to ASTM F714.



- B. Polyethylene: Virgin material with a minimum cell classification of PE 345464C for black and PE 345464E for colors following ASTM D3350.
- C. The pipe shall be homogenous throughout and shall be free of visible cracks, holes, foreign material, blisters, or other deleterious faults.
- D. Minimum nominal pressure rating of 160 psi.
- E. Hydrostatic Design Basis at 73.4 degrees F: 1,600 psi following ASTM D2837.
- F. Minimum wall thickness: SDR 13.5.
- G. Sectional lengths to provide continuous, homogeneous pipe along entire replacement section with enough extra length to allow relaxing and finishing off at manholes.
- H. Interior pipe color shall be a fully bonded light-colored interior liner meeting with the approval of the engineer.
- I. Pipe Markings:
  - 1. Mark following ASTM F714.
  - 2. Legibly marked in green to identify as sewer pipe.
- J. Molded fittings shall be manufactured, sized, and marked following ASTM D3261.
  - 1. Pressure rated and classified same as adjoining pipe.
  - 2. Inside diameter to match inside diameter of adjoining pipe.
- K. Field fabricated fittings shall be stock manufactured, sized, and marked following ASTM F714.
- L. Joint connection minimum requirements:
  - 1. Continuous pipe:
    - a. Assemble pipe lengths in field with butt-fused joints following ASTM D2657 and approved submittals or with electrofused joints following approved submittals.
    - b. In case of conflicts between ASTM D2657 and approved submittals or if the ASTM reference is nonspecific, follow approved submittals.
    - c. Joint strength shall be equal to or greater than pipe strength.
  - 2. Continuous pipe end and mid-section connections:
    - a. Joint pipe ends using butt-fused joints or electrofusion coupling.
    - b. With Engineer's approval, use full circle seal clamps or seal and restraint type mechanical couplings.
  - 3. Service line reconnections:
    - a. Heat fusion or electrofusion saddles.
    - b. Nominal inside diameter of existing service.
    - c. Made of polyethylene pipe compound following ASTM D3350 and suitable for fusion welding to polyethylene pipe.
    - d. Branch saddle style or approved equal.
  - 4. Appurtenances:
    - a. Use full circle elastomeric seal clamps for joining plain ends of pipe.
    - b. Rubber sleeve coupling with stainless steel shear ring.
    - c. Conform to ASTM C1173.

### 33.05.25.08 CASING SPACERS

- A. Non-metallic, projection type equal to RACI type spacer.

## EXECUTION

### 33.05.25.09 PUBLIC NOTIFICATION

- A. The Contractor shall be responsible for notifying all affected homeowners of any service outages realized by virtue of the work performed, whether planned or accidental.

### 33.05.25.10 SAFETY

- A. The contractor shall carry out operations in strict accordance with all applicable OSHA Standards. Particular attention is drawn to those safety requirements involving work entry into confined spaces. It shall be the contractor's responsibility to familiarize and its employees with OSHA Standards and regulations pertaining to all aspects of the work.
- B. Insertion and receiving excavations:
  1. The location and number of insertion and receiving excavations shall be planned by the contractor and submitted in writing for approval by the Engineer 14 days (or as determined by the Engineer) prior to excavation.
  2. Before excavation is begun, it will be the responsibility of the contractor to check with the various utility companies and determine the location of existing utilities in the vicinity of the work area. The contractor, at no cost to the City, if required, will arrange temporary construction easement and/or right-of-way areas.
  3. Damage to utilities and the resulting repair, temporary service cost, etc., shall be borne by the contractor. Access pits shall be backfilled in accordance with the appropriate specifications.
  4. All excavations shall be properly sheeted/shored in accordance with relevant specifications for trench safety systems. Any damage resulting from improperly shored excavations shall be corrected to the satisfaction of the Engineer with no compensation due to the contractor.
  5. All open excavations shall be kept secure at all times by the use of barricades with appropriate lights and signs, construction tape, covering with steel plates, etc., or as directed by the Engineer.
  6. One or more receiving pits shall be excavated at the end(s) of the pipe to be replaced or at appropriate points within the length of the existing pipe. Pits shall be centered over the existing pipe.
  7. The number of pits for machine and pipe insertion shall be the minimum necessary to most efficiently accomplish the work. The contractor shall give consideration to the use of excavation required for other purposes such as for service line reconnections and manhole replacement.
  8. Where manholes are used as machine or new pipe insertion pits, the contractor shall identify such manholes and replace them at no additional cost to the City if damaged. Any manhole modification or replacement required shall be considered incidental to the installation of the new pipe.

### 33.05.25.11 GENERAL

#### A. Bypass Pumping

1. Bypass pumping shall be accomplished when and where necessary.
2. The Contractor shall provide flow diversion with pumps adequate in size and capacity to handle all flows generated during the pipe replacement process.
3. All costs for bypass pumping shall be incidental unless specific pay items for this work are included on the bid schedule.

#### B. Preparation

1. Excavation of insertion pits shall be at locations determined by the Contractor and approved by the Engineer.
2. Insertion pits shall be of sufficient length to allow the bursting head and new HDPE pipe to enter the host pipe at an angle that will allow maintenance of the grade of the existing pipe to be replaced.
3. All service line connections shall be located prior to initiating the pipe replacement work.
4. It is recommended that the Contractor perform a pre-work video inspection to verify the pipe to be replaced does not have any obstructions or other anomalies which would preclude the planned work.
  - a. If a pre-work video inspection reveals obstructions or pipe materials that will prevent the existing pipe from being pipe burst / split properly and cannot be removed by conventional cleaning equipment, a point repair will be made by the Contractor.
  - b. Unless a separate item is included on the bid schedule, no separate payment for this work will be made as it will be considered incidental to the pipe replacement process.
  - c. If there is no separate item on the bid schedule and the Contractor opts not to perform a pre-work video inspection it will be at his risk and all costs associated with same shall be borne by the Contractor.
5. Before any excavation is done for any purposes, the Contractor shall contact the appropriate One-Call agency for determining field locations of existing utilities.

### 33.05.25.12 INSTALLATION

#### A. Main Piping

1. Pipe bursting tool shall be static and hydraulically operated. The bursting action of the tool shall increase the external dimensions sufficiently, causing pitting and breakage of the pipe at the same time expanding the surrounding ground. This action shall not only break the pipe, but also create the temporary void into which the burster can be statically pulled which enables forward progress to be made. Simultaneously, the new polyethylene pipe, directly attached to the expander, shall also move forward.
2. The polyethylene pipe shall be assembled and joined at the site using the butt-fusion method to provide a leak proof joint.
3. Threaded or solvent-cement joints and connections are not permitted.
4. All equipment and procedures used shall be in compliance with the manufacturer's specification for pipe bursting/splitting.
5. Fusing shall be accomplished by personnel certified as fusion technicians by a manufacturer of HDPE pipe and/or fusing equipment.

6. The butt-fused joint shall be in true alignment and shall have uniform rollback beads resulting from the use of proper temperature and pressure.
7. The joint shall be allowed adequate cooling time before removal of pressure.
8. The fused joint shall be watertight and shall have tensile strength equal to that of the pipe.
9. All defective joints shall be cut out and replaced at the expense of the Contractor.
10. If concrete encasements are encountered, a point repair shall be performed to excavate and break out concrete prior to the bursting operation to allow the steady and free passage of the pipe bursting head, with approval from the Owner/Engineer.
11. The new HDPE pipe shall be inserted immediately behind the bursting head in accordance with the manufacturer's recommended procedures.
12. The bursting tool shall be specifically designed and manufactured for the type of insertion process being used. It shall be utilized to guide and assist the bursting head during the operation.
13. A pushing machine may be utilized to aid pipe insertion from the rear.
14. New HDPE pipe shall extend a minimum of 6" into manholes.
15. The annular space shall be sealed at each manhole with Oakum saturated with Avanti AV-202 or an approved water stop gasket and finished with a quick setting grout.

#### B. Pipe Connections

1. Service connections to the HDPE pipe shall be made with materials submitted and approved.
2. An appropriate relaxation period shall be allowed prior to making service connections and connecting to manholes.
3. The relaxation period shall be appropriate with and dependent upon site conditions, as determined by the Contractor.
4. Services shall be reconnected so as to minimize disruption of service.
5. After the new HDPE pipe has been installed and tested, the Contractor shall be responsible for reconnecting existing sewer or water services in the manner described in the bid form.
6. All new service lines shall be the size indicated in the plans and specifications. In the absence of better information, the replacement size shall be at least the same nominal size as the original service line size.

#### C. Testing and Acceptance

1. After the new HDPE pipe is installed and all services are reconnected, the line shall be inspected by CCTV.
2. An inspection video shall be submitted to the Engineer or Owner for approval and acceptance of the line.
3. New sewer main inspection shall be performed in accordance with Section 33.31.20 – Sewer Main Cleaning and Inspection, including cleaning, as appropriate.
4. New water main inspection shall be performed in a manner approved by the Engineer which generally conforms with Section 33.31.20.06 (which relates to sewer main inspection).
5. New water main shall be tested in accordance with the related provisions of Section 33.11.13 – Potable Water Distribution.
6. New sewer main shall be tested in accordance with the related provisions of Section 33.31.13 – Sanitary Sewer Main.

## **PRICE AND PAYMENT**

### **33.05.25.13 REPLACEMENT PIPE**

- A. Measurement: By linear foot of each host pipe listed on the bid schedule installed and accepted measured horizontally along the center line.
- B. Basis of Payment: Includes all materials, labor, and equipment used for all excavation, bypass pumping, testing, reporting, safety and traffic control requirements, connections, modifications required to achieve desired finished results (e.g., manhole inlets, outlets, channels, etc.) and all other appurtenances and incidentals required to complete the work as specified.

### **33.05.25.14 RECONNECTION OF SERVICE LINES**

- A. Measurement: By unit price for each service line reconnection listed on the bid schedule installed and accepted measured. If service line replacement is called out on the bid schedule it shall be paid in accordance with the replacement pipe section above.
- B. Basis of Payment: Includes all materials, labor, and equipment used for all excavation, bypass pumping, testing, reporting, safety and traffic control requirements, connections, modifications required to achieve desired finished results and all other appurtenances and incidentals required to complete the work as specified.

### **33.05.25.15 CONNECTION TO MAINS**

- A. Measurement: By unit price for each main connection listed on the bid schedule installed and accepted measured.
- B. Basis of Payment: Includes all materials, labor, and equipment used for all excavation, bypass pumping, testing, reporting, safety and traffic control requirements, connections, modifications required to achieve desired finished results and all other appurtenances and incidentals required to complete the work as specified.

**END OF SECTION**

## **SECTION 33.11.13 – POTABLE WATER DISTRIBUTION**

### **GENERAL**

#### **33.11.13.01 SUMMARY**

- A. This section includes the installation of water mains, valves, hydrants, and other appurtenant structures for community water systems.

#### **33.11.13.02 RELATED WORK**

- A. Section 03.05.13 – Concrete
- B. Section 31.23.16 – Excavation, Trenching and Backfill
- C. Section 33.05.23 – Boring, Jacking, and Directional Drilling
- D. Section 33.11.15 – Water Service Lines

#### **33.11.13.03 REFERENCES**

- A. ANSI/AWWA C104/A21.4 – Cement-Mortar Lining for Ductile Iron Pipe and Fittings for Water.
- B. ANSI/AWWA C110/A21.10 – Ductile Iron and Gray Iron Fittings, 3 Inch Through 48 Inch, for Water and Other Liquid.
- C. ANSI/AWWA C111/A21.11 – Rubber-Gasket Joints for Ductile Iron and Gray Iron Pressure Pipe and Fittings.
- D. ANSI/AWWA C150/A21.50 – Thickness Design of Ductile Iron Pipe.
- E. ANSI/AWWA C151/A21.51 – Ductile Iron Pipe, Centrifugally Cast, for Water or Other Liquids.
- F. ANSI/AWWA C153/A21.53 – Ductile Iron Compact Fittings, 3 Inch Through 16 Inch, for Water and Other Liquids.
- G. ANSI/AWWA C502 – Dry Barrel Fire Hydrants
- H. ANSI/AWWA C509 – Resilient Seat Gate Valves for Water and Sewerage Systems
- I. ANSI/AWWA C515 – Reduced Wall, Resilient Seated Gate Valve for Water Supply Service
- J. ANSI/AWWA C600 – Installation of Ductile Iron Water Main and Their Appurtenances
- K. ANSI/AWWA C605 – Underground Installation of Polyvinyl Chloride (PVC) Pressure Pipe and Fittings for Water

- L. ANSI/AWWA C651 – Disinfecting Water Mains
- M. ANSI/AWWA C900 – Polyvinyl Chloride (PVC) Pressure Pipe, 4 Inch Through 12 Inch, for Water Distribution
- N. ASTM D2241 – Standard Specification for Poly(Vinyl Chloride) (PVC) Pressure-Rated Pipe (SDR Series)
- O. ASTM D3139 – Standard Specification for Joints for Plastic Pressure Pipes Using Flexible Elastomeric Seals
- P. ASTM F477 – Standard Specification for Elastomeric Seals (Gaskets) for Joining Plastic Pipe
- Q. Plastics Pipe Institute, Incorporated – Handbook of Polyethylene Pipe
- R. Standard Methods for Examination of Water and Wastewater

#### 33.11.13.04 SUBMITTALS

- A. Water Main and Fittings
- B. PE Pipe: Pipe Butt Fusing Equipment, if applicable
- C. PE Pipe: Transmission Main Couplings, if applicable
- D. Special Anchoring Retainer Glands, if applicable
- E. Gate Valves and Boxes with adaptors, if applicable
- F. Fire Hydrants and Flush Hydrants, if applicable
- G. Combination Air Release Valve, if applicable
- H. Air release pit with cover and insulation, if applicable
- I. Detectable Warning Tape, if applicable
- J. Utility Markers
- K. Method of Disinfection
- L. Water Testing Lab, if applicable
- M. Method of Connection to Existing Distribution System

#### 33.11.13.05 ACCEPTANCE

- A. Work covered by this section will not be accepted until the backfilling and testing connected with the work has been completed satisfactorily.

- B. Any section of water main that is found defective in material, alignment, or joints before acceptance shall be corrected to the satisfaction of the Project Engineer.

## PRODUCTS

### 33.11.13.06 WATER DISTRIBUTION PIPE AND FITTINGS

- A. Pipe size, material, and pressure rating as indicated in the contract documents.
- B. Ductile Iron Pipe.
- C. Conform to AWWA C151 with a thickness in accordance with AWWA C150.
- D. Pipe ends to have welded copper straps or other approved method to maintain electrical continuity throughout the length of the installed sections.
- E. Cement mortar lining conforming to AWWA C104.
- F. Coal tar epoxy or fusion bonded epoxy coating for buried pipe.
- G. Polyvinyl Chloride Pipe.
  - 1. Pipe: Conform to AWWA C900 (pressure class).
  - 2. Joints: Conform to ASTM D 3139 with elastomeric seals (gaskets) conforming to ASTM F477.
- H. High Density Polyethylene greater than 2".
  - 1. Pipe: AWWA C901 or C906, IPS dimensions.
  - 2. Joints:
    - a. Butt fused.
    - b. Fusion process conforming to U.S. Department of Transportation, DOT Title 49, Part 192.
  - 3. Transitions to PVC Pipe:
    - a. Polyethylene mechanical joint adapter.
    - b. Butt fused or polyethylene electrofusion coupling.
    - c. Electrofusion couplings equal to Central Plastics Company.
- I. Fittings
  - 1. Ductile Iron and PVC pipe greater than 6 inches.
    - a. Conform to AWWA C110 and AWWA C111 for ductile and gray iron fittings.
    - b. Conform to AWWA C153 for ductile iron compact fittings.
    - c. Interior and exterior fusion bonded epoxy coating conforming to AWWA C116, equal to PERMAFUSE®.
    - d. 250 psi pressure rating.
    - e. Type 316 stainless steel hex head bolts and nuts.
    - f. Flange joint gaskets equal to Garlock No. 19.
  - 2. SDR 26:
    - a. IPS PVC gasketed fittings with a 200 psi minimum pressure rating.
    - b. Joints conforming to ASTM D 3139 and ASTM F477.
    - c. Equal to Harco PVC fittings.



#### J. Thrust/Mechanical Restraint.

1. Special Anchoring Retainer Glands:
  - a. Ductile iron: Equal to 2000PV Megalugs, EBAA Iron, Inc.
  - b. PVC: Equal to 2000PV Megalugs, EBAA Iron, Inc.
2. Joint Restraint Rodding:
  - a. 3/4 inch stainless steel threaded rods.
  - b. Stainless steel Tie bolts.
  - c. Duc lugs.
3. (Optional, Not Required) Concrete Thrust Blocks:
  - a. One part Portland cement, 2 1/2 parts of fine aggregate, 3 1/2 parts coarse aggregate and just enough water for a workable consistency.
  - b. #4 rebar.

#### 33.11.13.07 GATE VALVES

- A. Meet or exceed AWWA C509 or C515.
- B. Gate valves shall meet the following criteria:
  1. Valves 2"-66" shall be resilient wedge type rated for 250 psi cold water working pressure. All ferrous components shall be ductile iron. This includes but is not limited to Stuffing Box, Valve Body, Valve Bonnet and Wrench nut /Operating nut.
  2. Valves 3"-16" shall be in full compliance with AWWA C-515. The words "DI" or "Ductile Iron" shall be cast on the valve or stamped on a permanently attached corrosion resistant metal. All ferrous parts of the valve shall be made of ductile iron ASTM A536, minimum 65,000 psi tensile strength.
  3. Valves shall have a label or tag, exhibiting a barcode that when scanned by a Trimble mobile device or approved smartphone and necessary software application, the device associates high accuracy GPS coordinates, photos, product description and specifications with the valve or hydrant asset. The application shall provide interoperability with existing ESRI® ArcGIS, computerized maintenance management systems (CMMS), or enterprise resource planning databases.
  4. All connecting pipe bolt holes must have anti rotation lugs to aid in installation
  5. Valves stems shall be full diameter from thrust collar to wrench nut, without any reduced area that allows premature failure or O-rings. O-rings shall be located in stuffing box. Stems with fracture grooves will not be accepted.
  6. Wedge nut shall be held in place on three sides. Valves with wedge nuts held in place by less than three side will not be accepted.
  7. The wedge shall be symmetrical and seal equally well with the flow in both direction and have wedge covers on both wedge guides made of Delrin.
  8. Seal between bonnet and body shall be a flat gasket with integral O-ring. Allowing bolting to pass through and hold the gasket in place. Standard O-rings or standard flat gaskets without integral O-rings will not be accepted.
  9. Valves 2"-66" shall be NSF Standard 61 certified.
  10. Valve shall have factory installed 304 stainless steel exterior bolting. All bolting on valves 4" and larger must be at least 5/8" diameter. Metric bolts, Allen head, and socket head cap screws will not be accepted.
  11. Operating nut shall be made of ductile iron and shall have four flats at stem connection to assure even torque input to the stem. All gaskets shall be pressure-energized O-rings.

12. Stem shall be a non-rising stem (NRS) sealed by three O-rings.
  13. Valve shall have thrust washers located with one above and one below the thrust collar to assure trouble-free operation of the valve.
  14. All internal and external surfaces of the valve body and bonnet shall be epoxy coated, complying with ANSI/AWWA C550.
  15. Connection shall be MJ or ALPHA valve inlet shall be restrained for use with ductile iron, cast iron, HDPE (without the use of a stiffener) and PVC materials. Inlet shall incorporate a stab-fit design using a single Type 304 stainless steel fastener and heat-treated ductile iron grippers. A full circumferential one piece end ring shall be used insuring even distribution of thrust restraint. SPLIT RINGS shall not be accepted. The assembly of the mechanical joint restrainers using multiple fasteners of wedge bolts that point load the pipe are not permitted. The joint shall work with pressure to achieve joint restraint. 4"-12" valves connections shall require a max torque of 30-45lbs. All hydrant inlets shall be the Romac ALPHA design, as furnished by AMERICAN Flow Control.
- C. Gate valves shall be equal to American Flow Control Series 2500.
- D. Stainless steel valve stem extensions with centering device shall be included.

#### 33.11.13.08 VALVE BOXES

- A. 2-piece, screw type, adjustable cast iron valve boxes equal to Tyler/Union model 6850.
- B. Locking cover with:
  1. ~~Brass cotter pin or brass rod as a keeper.~~
  2. "WATER" plainly marked.
- C. Valve box adaptor for connection of valve box to the valve, equal to Valve Box Adaptor II as manufactured by Adaptor Inc.
- D. Size valve box length to match bury depth of pipe.
- E. Valve stem extensions are not required if valve is less than 7 feet deep.

#### 33.11.13.09 FIRE HYDRANTS

- A. Conform to AWWA C502.
- B. Rated working pressure shall be 250 psi.
- C. Fire hydrants shall meet the following criteria:
  1. The nozzle section, caps, upper/lower standpipes and hydrant base shall be ductile iron.
  2. Nozzle shall be mechanically attached by collars. Pinned, threaded-in, screwed in or nozzles using set screws will not be allowed.
  3. Nozzles shall be two 2 ½ NST size and 4 ½ NST pumper.
  4. Nozzle section will be designed for easy 360-degree rotation by the loosening of no more than four bolts.

5. All external bolting must be Standard American English size nut and bolt design. Metric, hex-head (Allen) bolts, or threaded castings in place of nuts will not be accepted.
6. Hydrant shall measure 24 inches from ground line to center of nozzle. (16" upper barrel).
7. External bolting below grade shall be stainless steel bolting that meets the requirements of ASTM F 593, Standard Specification for Stainless Steel Bolts, Type 304, Alloy Group 1, CW condition and ASTM F 594, Standard Specification for Stainless Steel Nuts, Type 304, Alloy Group 1, CW condition.
8. Hydrant shall be open left.
9. External surfaces above grade shall be coated with two-part epoxy primer and a two-part high-gloss urethane red topcoat.
10. Valve or hydrant shall be supplied with a label or tag from the manufacture exhibiting a barcode that when scanned by a Trimble mobile device or approved smartphone and necessary software application, the device associates high accuracy GPS coordinates, photos, product description and specifications with the valve or hydrant asset. The application shall provide interoperability with existing ESRI® ArcGIS, computerized maintenance management systems (CMMS), or enterprise resource planning databases.
11. Hydrant must have an internal travel stop nut located in the top-housing hydrant. Hydrant must have a double oil reservoir so that operating threads are oil lubricated and will be O-ring sealed from water, moisture and foreign matter.
12. Hydrant must have a traffic flange design allowing for quick and economical repair of damage resulting from a vehicle's impact. The rod coupling must be two pieces bolted on by two stainless steel studs and four brass lock nuts. Pins, standard nuts, and bolts not allowed.
13. The seat diameter shall be 5 1/4", opening against the pressure and closing with the pressure. Hydrant must be designed so that removal of all working parts can be accomplished without excavating. The lower valve washer must be fusion-bonded epoxy coated. The bronze seat must be threaded into mating threads of bronze for easy field repair.
14. The draining system of the hydrant will be bronze and be positively activated by the main operating rod. Hydrant to be furnished with a sliding bronze drain valve, sliding drain valves made of *rubber, plastic or leather* will not be allowed.
15. Connection shall be MJ or ALPHA valve inlet shall be restrained for use with ductile iron, cast iron, HDPE (without the use of a stiffener) and PVC materials. Inlet shall incorporate a stab-fit design using a single Type 304 stainless steel fastener and heat-treated ductile iron grippers. A full circumferential one-piece end ring shall be used insuring even distribution of thrust restraint. SPLIT RINGS shall not be accepted. The assembly of the mechanical joint restrainers using multiple fasteners of wedge bolts that point load the pipe are not permitted. The joint shall work with pressure to achieve joint restraint. 4"-12" valves connections shall require a max torque of 30-45lbs. All hydrant inlets shall be the Romac ALPHA design, as furnished by American Flow Control.
16. Hydrant must have been in service for a minimum of 50 years and has maintained complete interchangeability of internal parts.
17. An arrow cast on the hydrant showing the direction of opening as counterclockwise.
18. Nozzle caps attached to upper barrel with individual chains.
19. Weep holes to allow the hydrant to drain.
20. Minimum 4 1/4-inch hydrant valve opening capable of opening against water pressure.

- 21. Minimum hydrant length of 7 feet, as measured from the ground line to the bottom of the trench carrying the connection pipe.
- 22. Hydrants must not be wrapped in such a way that would prevent the hydrant from properly draining.
- D. Coating system performance requirements for all exterior ferrous metal parts and surfaces above grade shall be coated to meet the minimum requirements of Section 4.2, *Painting*, in American Water Works Association Standard ANSI/AWWA C502-94 as follows:
  - 1. Primer: Primer shall be used on all surfaces and shall be cross-linked two-part liquid epoxy. Epoxy primer shall be applied using an electrostatic spray process.
  - 2. Topcoat: Surfaces shall be top coated with high-gloss two-part liquid urethane that uses an aliphatic isocyanate catalyst to produce a cross-linked cure. Topcoat shall be applied using an electrostatic spray process.
  - 3. Hydrant Base: The hydrant base shall be coated with fusion-bonded epoxy on interior and exterior surfaces using materials and coating application procedures that meet or exceed the requirements of AWWA C550-01 *Standard for Protective Epoxy Interior Coatings for Valves and Hydrants*.
- E. When a hydrant manufacturer and model is specified in the bid schedule, that exact unit must be supplied in order to maintain compatibility with the existing hydrants on the system.
- F. Provide *Waterous Pacer WB-67* hydrants.

### 33.11.13.10 FLUSH HYDRANTS

- ~~A. Supply 4-inch flush hydrants with:
 
  - 1. Traffic flange.
  - 2. 4 ½ - inch main valve opening.
  - 3. Equal to Mueller A 420.~~
- B. 2-inch post flush hydrants.
  - 1. Equal to Aquarius GP Post Hydrant as manufactured by GIL Industries.
  - 2. Ball valve curb stop equal to (Ford B44-777M-NL-Q)
  - 3. Curb stop box equal to A.Y. McDonald 5615.
  - 4. Corporation stop equal to FB1000-7-Q-NL
  - 5. 2" CTS 250psi Poly Service line with inserts
  - 6. Concrete slab conforming to Section 03.05.13.
    - a. 6 inch x 6 inch x 10 x 10 wire mesh reinforcement.

### 33.11.13.11 AIR/VACUUM RELEASE VALVES AND PITS

- A. Air Release Valve.
  - 1. Unless otherwise specified, the valve shall have a 1-inch air release air/vacuum breaker assembly.
  - 2. Equal to Val-Matic VM-200C-S.
- B. Air Release Pit.
  - 1. Pit constructed of 18-inch diameter PVC pipe section.

2. Extruded polystyrene insulation for 18-inch diameter pipe section, as manufactured by MacArthur Company.
  3. Locking cast iron lid with center locking nut.
  4. 4-inch foam insulation pad.
  5. Coiled polybutylene pipe.
  6. Equal to Mueller Thermal Coil
    - a. Model 330AR1878 for 6 to 6 ½ foot water main depth.
    - b. Model 330AR1884 for 7 to 7 ½ foot water main depth.
    - c. Model 330AR1890 for water main depths exceeding 8 feet.
- C. 1-inch brass gooseneck vent, end covered with 16 mesh type 304 stainless steel screen.
- D. 1-inch CTS polyethylene service line from the water main to the air release valve pit.
- E. Corp stop equal to Ford FB1000-4-Q-NL with inserts for HDPE compression fittings.
- F. Curb stop equal to Ford B44-444M-NL-Q \*with inserts for HDPE compression fittings.
- G. Corporation stop, curb stop box, and service line shall conform to Section 33.11.15.

#### 33.11.13.12 WARNING TAPE

- A. Supply detectable warning tape that is a minimum of 3 inches wide, blue or striped blue.
- B. Printed with “Caution Buried Waterline Below.”

#### 33.11.13.13 TRACER WIRE AND BOX

- A. Wire: Provide #10 AWG jacketed solid copper wire, type THHN/THWN.
- B. Box: Provide adjustable tracer wire access box manufactured by C.P. Test Services - Valvco, Inc or equal.
- C. Splice Kit: Provide underground waterproof splice materials.

#### 33.11.13.14 UTILITY MARKERS

- A. Supply blue utility markers, 62 inches in length.
- B. Standard decal printed with “Caution Buried Water Pipe Line.”

#### 33.11.13.15 POLYETHYLENE ENCASEMENT

- A. 8-mil polyethylene encasement.

#### 33.11.13.16 WATER TESTING LAB

- A. State certified lab.

### 33.11.13.17 ACCESSORIES

- A. Provide any accessory items required to operate an installed appurtenance to the owner when required by the Project Engineer.

## EXECUTION

### 33.11.13.18 WATER MAIN INSTALLATION

- A. Engineer to provide stakes in accordance with Section 01.71.23.
- B. Install water mains and appurtenances in the locations and of the sizes and materials shown on the plans and bid schedule.
- C. Refer to Section 31.23.16 for excavation, trenching, bedding, and backfill requirements and for minimum separation distances.
- D. Remove all dirt or foreign material from within the pipe prior to installing.
- E. Ensure pipe spigot and bell are clean before joining pipes.
- F. Install pipe with a minimum cover of 6 feet, measured from top of the pipe to finished grade.
- G. Installation depth may exceed minimum bury depth to eliminate high points in the main, except at locations of air release mechanisms shown on the plans.
- H. Coat all flange bolts with anti-seize lubricant.
- I. Coat all threaded connections and fittings with PVC thread sealant.
- J. Install trench "check dams" as per plans or per Owner directions.
- K. Once in place, the pipe shall have its open end plugged to prevent soil, water, or other matter from entering the pipe.
- L. Pipe Deflection:
  - 1. Deflection or bending of the pipe or deflection of the pipe joint (bell and spigot) shall not be permitted except as approved by the Engineer.
  - 2. Changes in horizontal and vertical direction shall be achieved using standard fittings, fabricated fittings, couplings, and/or high deflection pipe couplings specifically designed and approved for use in joint deflection.
  - 3. The Engineer may approve deflection of 12-inch diameter or smaller pipe or pipe joints if the "Engineer of Record" specifically designed for the deflection and the deflection is approved in writing by the pipe manufacturer specifically for the project.
  - 4. A condition of approval is the City of Box Elder receiving a letter from the pipe manufacturer stating they have reviewed the proposed pipe or pipe joint deflections for (*state the project name and City tracking number*) and they approve and warranty the pipe for the proposed deflections.

5. Deflection of pipe or pipe joints for diameters greater than 12-inch is strictly prohibited.
6. Certa-Lok C900/RJ pipe and couplings may be deflected in accordance with the manufacturer's written recommendations.
7. The Engineer shall specifically indicate the use of Certa-Lok C900/RJ pipe and indicate the designed deflections on the drawings.

M. Fittings:

1. Bends and tees shall be placed on a stable foundation, which may require the use of concrete pads of equal size or larger than specified for valves.
2. Fittings shall be provided with thrust blocks, joint restraining devices, and polyethylene encasement (where fittings which are not epoxy coated) as specified herein.

N. Couplings:

1. Couplings shall be placed on a stable foundation and shall be wrapped in polyethylene encasement as specified herein.
2. Couplings shall be approved by the pipe manufacturer for the use with the pipe and shall be installed according to the coupling manufacturer's recommendations.

O. Ductile Iron Pipe and fitting Installation.

1. Encase buried ductile iron pipe and fittings with 8 mil polyethylene encasements.

P. PE Pipe Installation.

1. HDPE Pipe Cold Bending:
  - a. 50-feet if not near a fitting or joint.
  - b. 100-feet if near a fitting or joint.
  - c. Make necessary provisions to ensure that localized curvature is within the tolerances over the length of curve.
  - d. For tighter curve requirements, use prefabricated HDPE fittings of the same DR and OD as the pipe.
2. Butt Fused Joints: Butt-fuse all HDPE joints, except as otherwise indicated
  - a. Strictly follow manufacturer's recommendations.
  - b. Ensure that HDPE pipes are of the same grade and dimensions.
  - c. Do not remove bead unless determined necessary. If bead is removed do not remove below pipe outside diameter.

Q. Thrust Blocking / Joint Restraints:

1. Install joint restraining devices on all fittings and appurtenances including in-line valves and hydrant tees.
2. Concrete Thrust Blocks: **(Optional)**
  - a. Concrete thrust blocks shall be provided at tees, crosses, horizontal bends, plugs, caps, fire hydrants, and similar locations whether specifically indicated on the drawings or not.
  - b. Concrete thrust blocks shall have a thickness at the fitting equal to at least half the diameter of the pipe being installed but shall not be less than six (6) inches thick under any circumstances.
  - c. They shall extend from the fitting to the undisturbed wall of the excavation.
  - d. The Contractor shall insure that the concrete does not cover or render inoperable nuts or bolts on the fittings.

- e. Place concrete thrust blocks so that the pipe and joints will be accessible for repair.
  - f. All metal fittings, valves, or appurtenances shall be wrapped in polyethylene prior to pouring thrust blocks.
  - g. Concrete thrust blocks shall be allowed to cure for 48 hours prior to activating the water main.
  - h. If the water main needs to be activated prior to the concrete curing (48 hours) then the water main shall be restrained using joint restraining devices.
  - i. Prior to backfilling, thrust blocks shall cure for a minimum of four hours.
  - j. Thrust blocks shall be installed as shown on the drawings and shall meet or exceed the minimum volume or bearing area requirements as specified on the drawings or specifications for the water pressures and soil conditions.
  - k. In muck, peat, or similar weak soils, thrust loads shall be resisted by using joint restraining devices or by removal of the soil and replacement with a material of sufficient stability to resist thrust loads as determined by the Engineer.
  - l. The use of thrust blocks, as specified above, is required when using Certa-Lok C900/RJ pipe and couplings.
  - m. Where prior approval of the Engineer is obtained, the Contractor may be able to substitute acceptable joint restraining devices for concrete thrust blocking.
3. Joint Restraining Device Installations:
- a. Install in accordance with manufacturer's recommendations.
  - b. Joint Restraining Devices are required for the following installations:
    - i. All pipe joints less than 20 feet from fittings with joint restraining devices.
    - ii. All valves 12 inches and larger and pipe joints within the minimum pipe lengths (see table below) for "CAP/VALVE."
    - iii. All high-pressure valves (working pressures greater than 110 psi) and pipe joints within their corresponding minimum pipe lengths (see table below).
    - iv. Valves 10 inches and smaller placed on dead-end mains with less than the minimum pipe length (see table below) downstream of the valve. Both the upstream and downstream pipe joints within their corresponding minimum pipe lengths (see table below) shall be restrained along with a thrust blocking at the dead-end.
    - v. All reducers/increasers and their corresponding minimum pipe lengths (see table below).
    - vi. All vertical bends and pipe joints within their corresponding minimum pipe length (see table below).
    - vii. All water main lowering and pipe joints shall be restrained. Water main lowering restraint shall include restraining all joints within the fitting's corresponding minimum pipe length (see table below) plus restraining all pipe joints which lie between the start of the lowering and the end of the lowering, regardless whether or not the pipe joint is located within the fitting's minimum pipe length.
    - viii. All joint restraint devices shall be double poly wrapped and taped (with each wrap taped separately) with approved polyethylene encasement. The polyethylene encasement ends shall be taped around the entire pipe diameter.
  - c. Engineer may specify additional restraint be used for pipe sections near critical fittings.



### MINIMUM PIPE LENGTHS TO BE RESTRAINED (FEET)

	6" PVC	8" PVC	10" PVC	12" PVC	14" PVC	16" PVC
BEND-HOR-11¼° *	3	4	5	6	7	7
BEND-HOR-22½° *	6	8	9	11	13	14
BEND-HOR-45° *	12	16	19	22	26	29
BEND-HOR-90° *	28	37	44	53	62	68
BEND-VER-11¼° *	8	11	13	15	17	19
BEND-VER-22½° *	16	21	25	30	35	39
BEND-VER-45° *	32	43	52	61	72	80
CAP/VALVE**	57	76	92	109	129	143
REDUCER X 6" ***	NA	32	57	80	103	121
REDUCER X 8" ***	NA	NA	31	58	84	104
REDUCER X 10" ***	NA	NA	NA	32	61	85
REDUCER X 12" ***	NA	NA	NA	NA	33	61
REDUCER X 14" ***	NA	NA	NA	NA	NA	33
REDUCER X 16" ***	NA	NA	NA	NA	NA	NA
TEE X 6" BRANCH****	42	37	32	27	22	16
TEE X 8" BRANCH****	64	60	56	52	49	44
TEE X 10" BRANCH****	82	79	76	73	70	66
TEE X 12" BRANCH****	101	99	96	93	91	88
TEE X 14" BRANCH****	121	119	117	114	112	110
TEE X 16" BRANCH****	137	135	133	131	129	127

\* Lengths shown are on either side of bend.

\*\* Lengths shown are for caps or valves on dead-end lines (except for valves >10").

\*\*\* Lengths shown are for branch (opposite thrust block). Main line restrained at tee.

\*\*\*\*Lengths shown are upstream of the reducer (along the larger pipe size).

R. Polyethylene Encasement:

1. All buried metallic items including fittings, valves, valve boxes, fire hydrants, pipe, and accessories, shall be encased in 8-mil thickness sheet polyethylene per AWWA Standard C105.
2. The polyethylene sheet shall be installed per AWWA C105 and taped.
3. The polyethylene shall fully encase the fitting and appurtenances.
4. Excess material shall be neatly trimmed away, and all seams shall be taped.

5. Any transition between the polyethylene sheet and PVC pipe or the DI poly tube shall be accomplished by sealing the ends of the sheet and taping the material fully around the circumference of the pipe.
6. Cost of the encasement shall be incidental to the bid price of the fitting.

S. Insulation:

1. Insulation shall be placed where noted on the plans.
2. Insulation board shall be placed on a smooth and level cushion, minimum of 2 inches, of fine concrete aggregate (sand) and shall be covered with a minimum of 2 inches of the same material before placing bedding or backfill material on the insulation.
3. The build-up of insulation sheeting shall be done by staggering the joints. An acceptable adhesive may be used to retain the individual sheets in the final specified dimensions.
4. Either the Engineer or Contractor may request to use insulation.
5. Use of insulation shall be approved by the Engineer.

T. Dewatering:

1. Refer to Section 31.23.19.

### 33.11.13.19 GATE VALVE INSTALLATION

- A. Refer to Section 31.23.16 for excavation and backfill requirements.
- B. Install valves at locations indicated on the plans.
- C. Install suitable thrust restraints on all valves.
- D. Support gate valves on a poured concrete block as shown on the plans.
- E. Set valves plumb and provide with a valve box.
- F. Install stainless steel valve stem extension with a centering device to the gate valves to within 2 feet of the finished grade.
- G. Secure valve stem extension to the valve stem with a set screw.
- H. Wrap valves with 8 mil polyethylene encasement.
- I. Install valve box on valve using a valve adaptor.
- J. Center the valve box over the valve with the box cover:
  1. Flush with finished grade elevation.
  2. Flush with the surfaced street.
  3. 3 inches below the level of an unimproved street.

~~K. Provide one gate valve key and valve box cover key per job requiring valve installation.~~

### 33.11.13.20 HYDRANT INSTALLATION

- A. Refer to Section 31.23.16 for excavation and backfill requirements.

- B. Install hydrant and auxiliary gate valve at the location indicated on the plans.
- C. Connect auxiliary gate valve to tee using a *Minimum* 3-foot section of water main pipe unless alternative installation is approved by City Engineer.
- D. Connect hydrant to auxiliary gate valve using a *minimum* 3-foot section of water main pipe unless alternative installation is approved by City Engineer.
- E. Install suitable thrust restraint on tee, valve, and hydrant.
- F. Set hydrant on a poured concrete block and restrain as shown on the plans.
- G. Set hydrant with the traffic flange at an elevation of 1 to 3 inches above finished grade.
- H. Stand hydrant plumb with the pumper nozzle toward the street.
- I. Install suitable thrust restraint at the base of each hydrant as shown on the plans or detailed in these specifications.
  - 1. Do not obstruct proper operation of weep hole(s).
- J. Place aggregate, a minimum of 18 cubic feet per hydrant, from 18 inches below to 6 inches above the weep hole opening.
  - 1. Cover aggregate in geotextile.
  - 2. Aggregate specifications shall be approved by the Engineer prior to installation.
- ~~K. Provide one hydrant wrench per each job requiring a hydrant installation.~~

#### 33.11.13.21 FLUSH RISER INSTALLATION

- A. Refer to Section 31.23.16 for excavation and backfill requirements.
- B. Install riser and auxiliary curb stop at the location indicated on the plans.
- C. Connect to main using 2-inch CTS 250psi poly service line with compression connections.

#### 33.11.13.22 AIR/VACUUM RELEASE VALVE AND PIT INSTALLATION

- A. Install combination air/vacuum release valve and pit at locations indicated on the plans.
- B. Install pit on a minimum of 6 inches of clean, crushed rock.
- C. Install insulation around the pit from the ground surface to the water main.
- D. Install screened outlet vent on the valve exhaust port.
- E. Outlet vent screening shall be heavy gauge stainless steel.
- F. Connect to the water main in accordance with Section 33.11.15.

- G. Install the 1-inch polyethylene service line to the air release valve with slope upward from the main to the air release pit. This may require the water main to be buried at an additional depth.
- H. Install curb stop and connect to the air release valve pit with the threaded brass nipple stubbed out from the pit.
- I. Place curb stop on a concrete block.
- J. Refer to Section 31.23.16 for insulating, excavation, backfill requirements.
- ~~K. Provide one shut off key and pentagon wrench per each job requiring a combination air/vacuum valve installation.~~
- L. Fabricate and provide one lifting tool for air release valve, as shown in the plan details.

#### 33.11.13.23 WARNING TAPE INSTALLATION

- A. Install warning tape in water main trench 2 feet below finished grade.

#### 33.11.13.24 TRACER WIRE AND BOX INSTALLATION

- A. Wire:
  - 1. The tracer wire shall be extended along with the water main.
  - 2. The wire shall be installed along the top of the pipe and shall be securely anchored to the pipe every 4 feet horizontally with an adhesive tape.
  - 3. The tracer wire shall be extended along all water main branches and hydrant leads as well.
  - 4. At fire hydrant leads two (2) tracer wires (the upstream tracer wire and the downstream tracer wire) shall be brought along the lead and brought to the surface at the fire hydrant.
  - ~~5. The upstream and downstream tracer wire at fire hydrants shall not be tied together as this is intended to allow independent tracing of the downstream and upstream main.~~
- B. Tracer Wire Access Box:
  - 1. A Tracer Wire Access Box shall be installed at fire hydrants in all cases and when specified on the drawings at valve boxes or other locations.
  - 2. The tracer wire access box shall be centered 6 inches to 12 inches behind the fire hydrant.
  - 3. Both the upstream and downstream tracer wires shall be installed in the tracer wire access box.
  - 4. The tracer wires shall be taped to the fire hydrant barrel in at least five locations below the ground surface.
  - 5. The tracer wire shall be extended at least three (3) feet above the top of the access box, the wires connected to the access box lid, the wires folded, and inserted back into the Access Box for storage.
  - 6. The wire shall be easily retrievable for connection to and subsequent tracing.

C. Splice Kit:

1. All tracer wire connections shall be accomplished through the use of “pigtails”.
2. All splices and “pig-tails” shall be accomplished by stripping the wires to be connected, twisting the wires together, securing the connection by using an appropriately sized wire nut, and then preserving the splice or “pig-tail by using a direct bury splice kit.
3. The main line tracer wire shall run continuous along the main(s) from fire hydrant to fire hydrant but shall not be continuous at fire hydrants.
4. At fire hydrants two tracer wires shall be installed, one wire is the main line wire from downstream of the fire hydrant and the second wire is the main line wire going upstream of the fire hydrant.
5. ~~The main line tracer wire shall not be interconnected at the fire hydrant or at the main.~~

33.11.13.25 UTILITY MARKER INSTALLATION

- A. Install two (2) plastic utility markers at each gate valve, air release pit and manhole. **(As required by the project engineer)**
- B. Place markers at the fence line or as designated by the Project Engineer.

33.11.13.26 PRESSURE AND LEAKAGE TESTING – PVC

- A. Whenever practical, before backfilling is fully placed or joints fully covered, test pipe for leaks in the presence of a *City of Box Elder* representative.
- B. Furnish necessary material, equipment, and labor for testing including, but not limited to: water, pump, water storage vessel, piping, pressure gauge, valve, hydrant, and corporation stop.
  1. Pressure gauge shall be liquid filled with 5 psi or less increments.
- C. Test duration: 2 hours minimum.
- D. Testing Procedure – Test in accordance with the Hydrostatic Testing Method outlined in ANSI/AWWA C605.
  1. Slowly fill test section with water and expel air from mains.
  2. Install corporation stops at high points to facilitate removal of air, if necessary.
    - a. Remove corporation stops and plug prior to pressure testing.
  3. Verify all hydrant lead valves and main valves within the test section are open.
  4. Place test section under constant pressure as shown in the table below, as measured at the lowest point of the section.

<b>Classification of PVC Pipe</b>	<b>Test Pressure</b>
SDR-26	150 psi
SDR-21	175 psi
SDR-17	200 psi

5. If pressure drops more than 5 psi during the test, immediately re-pressurize the line to the original test pressure and continue test.
  - a. Record amount of water required to re-pressurize the line.
6. At the end of the test, re-pressurize the line to the original test pressure.

- a. Record amount of water required to re-pressurize the line.
- 7. Add total amount of water required to re-pressurize the line during and at the end of the test and compare with the allowable leakage as calculated below.
  - a. If leakage is greater than allowable leakage, the test fails.
- 8. Allowable Leakage Determination:

$$L = (N * D * P^{1/2}) / 7400$$

- Where:
- L = Allowable Leakage (gph)
  - N = Total Length Tested Divided by The Standard Pipe Length
  - D = Nominal Diameter of Pipe (inches)
  - P = Test Pressure (psi)

**Example Allowable Leakage Chart Using Formula Above  
PVC Pipe with 20-foot Sections**

Pipe Diameter, D	Allowable Leakage/ 1000 feet (gph)				
	P = 100 psi	P = 150 psi	P = 175 psi	P = 200 psi	P = 250 psi
1 ½-inch	0.10	0.12	0.13	0.14	0.16
2-inch	0.14	0.17	0.18	0.19	0.22
4-inch	0.27	0.33	0.36	0.38	0.43
6-inch	0.41	0.50	0.54	0.57	0.64
8-inch	0.54	0.66	0.72	0.76	0.85
10-inch	0.68	0.83	0.89	0.96	1.07
12-inch	0.81	0.99	1.07	1.15	1.28

- 9. Repair, at no cost to Owner, any section of the line that fails this test.
- 10. Retest all repaired sections of line, at no cost to Owner, until pressure test is successfully completed.

**33.11.13.27 PRESSURE AND LEAKAGE TESTING – DUCTILE IRON**

- A. Whenever practical, before backfilling is fully placed or joints fully covered, test pipe for leaks in the presence of a City of Box Elder representative.
- B. Furnish necessary material, equipment, and labor for testing including, but not limited to: water, pump, water storage vessel, piping, pressure gauge, valve, hydrant, and corporation stop.
  - 1. Pressure gauge shall be liquid filled with 5 psi or less increments.
  - 2. Test duration: 2 hours minimum.
  - 3. Testing Procedure – Test in accordance with the Hydrostatic Testing Method outlined in ANSI/AWWA C600.
    - a. Slowly fill test section with water and expel air from mains.
    - b. Install corporation stops at high points to facilitate removal of air, if necessary.
      - i. Remove corporation stops and plug once test completed.
    - c. Verify all hydrant lead valves and main valves within the test section are open.
    - d. Place test section under constant pressure.
      - i. 1.5 times working pressure or 150 psi, whichever is greater.
      - ii. Do not exceed 115% of pipe pressure rating at the lowest point in the test section.

- e. If pressure drops more than 5 psi during the test, immediately re-pressurize the line to the original test pressure and continue test.
    - i. Record amount of water required to re-pressurize the line.
  - f. At the end of the test, re-pressurize the line to the original test pressure.
    - i. Record amount of water required to re-pressurize the line.
  - g. Add total amount of water required to re-pressurize the line during and at the end of the test and compare with the allowable leakage as calculated below.
    - i. If leakage is greater than allowable leakage, the test fails.
4. Allowable Leakage Determination:
- $$L = (S \cdot D \cdot P^{1/2}) / 133,200$$
- Where:
- L = Allowable Leakage (gph)
  - S = Total Length of Pipe Tested (feet)
  - D = Nominal Diameter of Pipe (inches)
  - P = Test Pressure (psi)

**Example Allowable Leakage Chart Using Formula Above  
Ductile Iron Pipe per 1,000 feet of pipe**

Pipe Diameter, D	Allowable Leakage/ 1000 feet (gph)			
	P = 100 psi	P = 150 psi	P = 200 psi	P = 250 psi
4-inch	0.30	0.37	0.43	0.47
6-inch	0.45	0.55	0.64	0.71
8-inch	0.60	0.74	0.85	0.95
10-inch	0.75	0.92	1.06	1.19
12-inch	0.90	1.10	1.28	1.42

- 5. Repair, at no cost to Owner, any section of the line that fails this test.
  - a. Retest all repaired sections of line, at no cost to Owner, until pressure test is successfully completed.

**33.11.13.28 PRESSURE AND LEAKAGE TESTING – PE**

- A. Whenever practical, before backfilling is fully placed or joints fully covered, test pipe for leaks in the presence of a City of Box Elder representative.
- B. Furnish necessary material, equipment, and labor for testing including, but not limited to: water, pump, water storage vessel, piping, pressure gauge, valve, hydrant, and corporation stop.
  - 1. Pressure gauge shall be liquid filled with 5 psi or less increments.
  - 2. Test duration: 1 hours minimum.
  - 3. Testing Procedure – Test in accordance with the recommendations from the Plastic Pipe Institute:
    - a. Slowly fill test section with water and expel air from mains.
    - b. Install corporation stops at high points to facilitate removal of air, if necessary.
    - c. Remove corporation stops and plug once test completed.
    - d. Verify all hydrant lead valves and main valves within the test section are open.
    - e. Place test section under constant pressure.
      - i. 1.5 times working pressure or 150 psi, whichever is greater.
      - ii. Do not exceed 115% of pipe pressure rating at the lowest point in the test section.

- f. To allow for pipe expansion, add water as required to maintain test pressure for four (4) hours.
- g. To test, reduce pressure by 10 psi.
  - i. If pressure remains within 5% of target test value, test passes.

#### 33.11.13.29 DISINFECTION OF WATER MAIN AND FITTINGS

- A. Disinfection shall conform to AWWA C651.
- B. Obtain water at the site for disinfection.
- C. Flushing chlorinated water in accordance with AWWA C651.
  - 1. Waste flushed disinfection water in an environmentally safe manner. The method used is subject to the approval of the Project Engineer.
- D. After disinfecting and flushing but before the water main is placed in service, collect and test water samples for bacteriological quality.
  - 1. Sample in accordance with the Standard Methods for Examination of Water and Wastewater.
  - 2. Take two consecutive tests, 24 hours apart.
  - 3. Collect one sample from the new water main and one from end of each branch line.
    - a. Additional samples may be required on extremely long mains.
  - 4. Take samples to an EPA certified testing lab.
  - 5. Permanent sampling taps may be required at the direction of the Engineer.
- E. If initial disinfection fails to produce satisfactory bacteriological results, re-chlorinate the mains and branch lines, flush and take new samples until satisfactory results are obtained.
  - 1. Do not place main in service until the Project Engineer has received safe bacteriological results.

#### 33.11.13.30 CONNECTIONS TO EXISTING DISTRIBUTION SYSTEMS

- A. Shutoff of mains will not be permitted overnight, over weekends, or on federal holidays.
- B. Coordinate system tie-in with the Owner and/or operator of the existing utility a minimum of **five** working days before any connection is made.
- C. Notify residents affected by the water shutoff of the time and day of shutoff a minimum of two working days in advance.
- D. Connect using stainless steel tapping sleeve with an **MJ valve**.
- E. Start work when all the materials, equipment and labor are on site.
- F. Clean all connection components with a chlorine solution prior to installation.
- G. Once work on the connection has commenced, it shall proceed continuously without interruption, and as rapidly as possible until completed.



- H. Visually inspect any joints not pressure tested for leakage.
  - 1. Test under system pressure prior to backfilling.
  - 2. Test in the presence of the City representative.
  - 3. Repair and retest any joint with leakage until no leakage is visible at no cost to the Owner.
  
- I. Health Hazards.
  - 1. Whenever, in the opinion of the Engineer, a health hazard exists because of actions or inactions of the Contractor, the Contractor shall immediately correct the situation to the satisfaction of the Engineer.
  
  - 2. If not corrected in a timely manner, the City may cause to take any actions necessary to remove the health hazard and charge the Contractor one and a half (1.5) times the cost incurred.
  
- J. Damages to Property
  - 1. Any damage to private or public property due to negligence, flooding, overflows, or interruption in services resulting from work under this section shall be the responsibility of the Contractor and shall be corrected as soon as practical and at no cost to the City.
  
  - 2. If not corrected in a timely manner, the City will take the necessary action and charge the Contractor one and half (1.5) times the cost incurred.

## **PRICE AND PAYMENT**

### **33.11.13.31 WATER MAIN**

- A. Measurement shall be by the linear feet measured over the centerline of the pipe.
  
- B. Basis of payment shall include all pipe, fittings, encasement, insulation, warning tape, tracer wire, flushing, disinfection, and testing as specified.

### **33.11.13.32 WATER MAIN APPURTENANCES**

- A. Measurement shall be by each installed and includes any and all boxes, pits, valves, markers, risers, drainage, etc. indicated in the pertinent specification and/or shown in the detail to make the appurtenance functional.
  
- B. Basis of payment shall include all labor, equipment, and materials for all valves, fire hydrants, flush hydrants, air/vacuum release valves, and all other appurtenances required to complete the work as specified.

**END OF SECTION**

## SECTION 33.11.15 – WATER SERVICE LINE

### GENERAL

#### 33.11.15.01 SUMMARY

- A. Work covered by this section includes installation of water service piping (line) and curb stops with boxes. Any other appurtenances installed will be at the discretion of the developer or homeowner.
- B. The water service line and appurtenant structures shall be constructed at the locations and of sizes and materials shown on the drawings and bid schedule.

#### 33.11.15.02 RELATED WORK

- A. Section 03320 – Potable Water Distribution

#### 33.11.15.03 REFERENCES

- A. ASTM B88 – Standard Specification for Seamless Copper Water Tube.
- B. AWWA C901 – Polyethylene (PE) Pressure Pipe and Tubing, 3/4 in. through 3 in. for Water Service.
- C. AWWA C904 – Cross-Linked Polyethylene (PEX) Pressure Pipe, 1/2 in. through 3 in. for Water Service.
- D. ASTM F2023 – Standard Test Method for Evaluating the Oxidative Resistance of Crosslinked Polyethylene (PEX) Pipe, Tubing and Systems to Hot Chlorinated Water.

#### 33.11.15.04 SUBMITTALS

- A. The following shall be submitted for approval in accordance with this section:
  - 1. Water Service Line
  - 2. Fittings
  - 3. Saddles, Tees or Tapped Couplings
  - 4. Curb Stops and Boxes
  - 5. Water Testing Lab
  - 6. Water Service Meter Pit

#### 33.11.15.05 PRODUCT DELIVERY, STORAGE, AND HANDLING

- A. Deliver products on manufacturer's original skids or in original unopened protective packaging.
- B. Store material to prevent physical damage.
- C. Protect materials during transportation and installation to avoid physical damage.

## PRODUCTS

### 33.11.15.06 PIPE

#### A. Copper:

1. Copper water service line shall be type "K" copper tubing manufactured in accordance with ASTM B88.

#### B. Polyethylene (PE):

1. Polyethylene water service line shall be PE4710 250psi and meet the requirements of AWWA C901:
  - a. CTS size shall be DR 9

#### C. Cross-Linked Polyethylene (PEX):

1. Cross-Linked Polyethylene water service line shall be PEX-a and meet the requirements of AWWA C904 and a minimum mean life expectancy of 50 years using ASTM F2023.
2. CTS size shall be DR 9.

### 33.11.15.07 VALVES

#### A. Corporation Stops:

1. Corp stops shall be ball valves and be rated for 300-psig working pressure. They shall be constructed of lead-free brass or bronze and have AWWA iron pipe threads and be Ford FB1000-X-Q-NL, or equal. Corporation stops that are used to connect copper water services to metallic water mains shall be the isolator style or insulated corporation ball valve.

#### B. Curb Stops:

1. Curb stops shall be ball valves with a 90-degree valve operation and be rated for 300-psig working pressure. They shall be constructed of lead-free brass or bronze and have AWWA iron pipe threads and be Ford B44-444M-NL-Q with Minneapolis top thread, or equal.

#### C. Curb Stop Boxes:

1. Boxes shall be adjustable to the depth of the installed curb stops to which they will connect and have a Minneapolis pattern base to mate with installed curb stops and shall be Mueller H-103 series, or equal.
2. Boxes shall be capable of telescoping, at a minimum, from five (5) feet to a length of six (6) feet.
3. Box lids shall be marked "water."
4. Risers shall be a minimum of 1.25 (1-1/4) inches in diameter.

### 33.11.15.08 MISC.

#### A. Meter Pit Assemblies:

1. Residential single family meter pit assemblies shall be coil-type with a pit depth of 72", flat locking cover (cast iron or composite traffic rates lid required if to be installed in driveway), with integral backflow prevention (double check valve), lead-free meter connections, and insulation provided by the manufacturer for the meter pit assembly.

2. Residential single family meter pit assemblies shall be, Mueller 203CS1572FSBSN, or approved equal.
3. Multi-family residential and commercial water service meter installations shall be approved by the City prior to installation.
4. The City will not meter individual units of a multiple unit complex. Each complex/development will have a master meter, which the city will monitor and base billing upon.
5. Meters located in mechanical rooms must have external access or have meter placed on the outside of building in an approved meter pit.

B. Service Connections-General:

1. Service saddles for 1 inch through 2 inches copper service pipe shall utilize a wide band/strap with a minimum of two (2) bolts and nuts, per width of the band/strap, for securing the band/strap to the main. The saddle shall provide full support around the circumference of the pipe. Nuts and bolts shall be rolled thread stainless steel or silicon bronze. Gaskets shall be neoprene or NBR compounded for water service.
2. It shall be the Contractors responsibility to ensure that saddles and corporation stops are compatible with the pipe on which they are to be installed. If a compatibility question arises, the Contractor shall inform the Engineer and provide him with a recommended substitution.
3. Service line copper splicing couplings shall be flared or compression type such as Mueller 110 Conductive Compression, Hayes-Tite, or equal. Soldered joints shall not be used for service lines installed underground.
  - a. Service Saddles – 6-inch to 12-inch mains:

C. Saddles for 6-inch – 12-inch mains shall utilize a stainless steel, cast brass per ASTM B62, bronze, or a high strength ductile iron body with a minimum 12 mils of fusion applied epoxy or Nylon 11 coating and a stainless-steel band.

1. Saddles shall be pre-sized if required or recommended by the saddle or pipe manufacturer. Pre-sized saddles will conform to the pipe O.D. without placing undue stress on the PVC pipe. Not all of the following indicated saddles are pre-sized and it is the responsibility of the Contractor and supplier to ensure that the saddle is pre-sized if required or recommended by the saddle or pipe supplier.
2. 1-inch Service Taps:
  - a. Provide a minimum total band/strap width of 2 inches along the axis of the pipe.
  - b. Shall be Ford Style FS303 or FC202, Romac Style 306, Style 202N and 202BS with SS straps, A. Y. McDonald Model 3845, Mueller DR2S series with double studs, or approved equal.
3. 1½-inch & 2-inch Service Taps:
  - a. Provide a minimum total band/strap width of 3¼ inches along the axis of the pipe.
  - b. Shall be Ford Style FS303 or FC202, Romac Style 306, Style 202N and 202BS with SS straps, A. Y. McDonald Model 3845, Mueller DR2S series with double studs, or approved equal.

D. Service Saddles – 14-inch and larger mains:

1. Saddles for 14 inches and larger mains shall utilize a stainless steel, cast brass per ASTM B62, bronze, or a high strength ductile iron body with a minimum 12 mils of fusion applied epoxy or Nylon 11 coating and a stainless-steel band.

2. Saddles shall be pre-sized if required or recommended by the saddle or pipe manufacturer. Pre-sized saddles will conform to the pipe O.D. without placing undue stress on the PVC pipe. Not all of the following indicated saddles are pre-sized and it is the responsibility of the Contractor and manufacturer to ensure that the saddle is pre-sized if required or recommended by the saddle or pipe supplier.
  3. 1-inch Service Taps:
    - a. Provide a minimum total band/strap width of 2 inches along the axis of the pipe.
    - b. Shall be Ford Style FC202, Romac Style 202N and 202BS, and Mueller DR2S, with SS straps, or approved equal.
  4. 1½ inches & 2 inches Service Taps:
    - a. Provide a minimum total band/strap width of 3 inches along the axis of the pipe.
    - b. Shall be Ford Style FC202, Romac Style 202N and 202BS, and Mueller DR2S with SS straps, or approved equal.
- E. Service Lines – greater than 2-inch:
1. Tapping sleeves and valves shall be used for service lines larger than 2 inches.
- F. Fittings:
1. All fittings shall be brass or bronze with compression couplings in accordance with AWWA C901.
- G. Joint Restraining Devices:
1. In general, solid ring restraints shall be used whenever possible.
  2. Split restraints may be used when connecting to existing systems, for special cases, and when a solid ring restraint is not available for the application.
  3. All joint restraint devices shall be epoxy coated (min. 6 mils), utilize the “E Coat” coating system as specified by the Ford Meter Box Co., Inc., or utilize the “Mega-Bond” coating system as specified by EBBA Iron, Inc.
  4. All bolts, rods, etc. shall be COR-Blue, epoxy coated, stainless steel, or fluoropolymer coated per EBBA Iron, Inc. and the Ford Meter Box Co., Inc. specifications.
  5. DI pipe to DI push-on fittings:
    - a. Fitting joint restraints shall be EBAA Series 1100HD, or equal.
  6. DI pipe to DI MJ fittings:
    - a. Fitting joint restraints shall be EBAA MEGALUG Series 1100, Series 1100SD, or equal.
  7. PVC pipe to DI push-on fittings:
    - a. Fitting joint restraints shall be EBAA Series 15PF00, or equal.
  8. PVC pipe to DI MJ fittings:
    - a. Fitting joint restraints shall be EBAA Series 2000PV, Series 2000SV, Series 15PF00, or equal.
  9. PVC pipe to PVC push-on fittings:
    - a. Fitting joint restraints shall be EBAA Series 2500, or equal.
  10. Joint Restraint Devices at pipe bells shall meet the following requirements:
    - a. DI pipe:
      - i. The bell restraint shall be EBAA Series 1700, or equal.
      - ii. In lieu of bell restraint devices, push on joints with the American Fastite Joint system with Fast Grip Gasket, or equal may be used when approved by the Engineer.
    - b. PVC C-900 pipe:

- i. The bell restraint shall be EBAA Series 1600, or equal.
  - c. PVC C-905 pipe:
    - i. The bell restraint shall be EBAA Series 2800, or equal.
- H. Tracer Wire System:
  - 1. Tracer wire shall be a direct bury wire system that meets or exceeds the following requirements:
    - a. Conductor:
      - i. Wire: Provide #10 AWG jacketed solid copper wire, Type THHN/THWN.
    - b. Tracer Wire Access Box:
      - i. Provide adjustable tracer wire access box manufactured by C.P. Test Services – Valvco, Inc. or equal.
    - c. Splice Kit:
      - i. Splice Kit/Connectors -3M epoxy type compounds, fusible heat-shrink tubing, 3M DBY connectors, or Snaploc LV 9000 direct bury wire connectors, or equal.
- I. Polyethylene Encasement:
  - 1. Polyethylene Encasement (poly-wrap) shall meet AWWA C-105.
  - 2. For ductile iron pipe, the encasement shall be 8-mil thickness, seamless tube, black ASTM D-1248, Type 1, Class C, Grade G-1. Joint tape for encasement shall be 3M Scotch wrap 50, or equal.
  - 3. For fittings and joint restraining devices, which are not epoxy coated, the encasement shall be 8-mil thickness sheet polyethylene meeting AWWA C-105.
  - 4. Joint tape for encasement shall be 3M Scotch wrap 50, or equal.
- J. Concrete Thrust Blocks (Optional):
  - 1. Thrust blocks shall be 4000 psi concrete as specified in Sections 03.05.13 and 33.11.13 of these specifications.
- K. Pipeline Insulation:
  - 1. Pipeline insulation shall be extruded-polystyrene Board Insulation formed from polystyrene base resin by an extrusion process using hydrochlorofluorocarbons as blowing agent to comply with ASTM C578, type IV, with 1.60 lb./cu. ft. minimum density and a compressive strength of 25 psi as specified in ASTM D1622 and ASTM D1621 respectively.
  - 2. The maximum thermal conductivity of the insulation shall conform to ASTM C518, C177, and C578.
  - 3. The maximum water absorption percentage by volume shall be 1% in accordance with ASTM D2842. The range of water vapor permeance shall be 0.4 to 1.0 perm in accordance with ASTM E96.
  - 4. Pipeline insulation shall be Type IV Styrofoam Brand “Square Edge” or “Score Edge” as manufactured by Dow Chemical Company or approved equal shall be used for insulating water pipes where required.
  - 5. The total thickness and dimensions shall be specified on the drawings or in the specifications. However, the minimum insulation thickness shall be 2 inches.

## EXECUTION

### 33.11.15.09 EXCAVATION, TRENCHING, AND BACKFILLING

A. Excavation, trenching, and backfilling shall be in accordance with section 31.23.16.

### 33.11.15.10 PIPE AND FITTINGS

A. Pipe Installation:

1. Water service line shall be laid by placing the pipe on the trench bottom with sufficient slack to prevent pulling apart of the joints when the backfill is placed, or from contraction of the pipe length due to temperature changes. No splices allowed with the approval of the project engineer.

B. Installing Fittings, Stops and Boxes:

1. Corporation stops shall be tapped into the main with an approved tapping machine, inserted into heavy duty tapped couplings, or inserted in approved service clamps. All compression couplings made with IDR 9 or DR 9 PE or PEX must have stainless steel stiffeners.
2. They shall be set as indicated on the drawings. Curb stops shall be set on a solid concrete block 4" thick by 8" x 16" (min.) placed on undisturbed earth. The top of the service box shall be set flush with the ground or adjacent sidewalk or curb. The service box shall be set vertical and supported during the backfilling operation to prevent movement.

C. Water Service New Connections:

1. Where new service lines are to be installed for undeveloped property or future buildings or additional services added to an existing building, the Contractor shall furnish all materials necessary for connection of new service lines to the water main, as specified herein and shall obtain and pay permits and tapping fees as established by Ordinance.
2. Where the new service line is terminated, the service line shall be capped and plugged watertight to prevent leakage if the curb stop is inadvertently opened.
3. New service connections shall have curb stops left turned off at the time of installation and the termination point shall be marked with a minimum three (3) foot long steel fence post.
4. The steel post shall be buried below the surface eight (8) inches. The post needs to be steel to facilitate location by magnetic locators.
5. City personnel shall inspect all city water main taps, the Contractor shall schedule all service taps inspections between 7:30 AM to 3:00 PM, Monday through Friday.

D. Water Service Reconnections:

1. The Contractor shall furnish all materials necessary for reconnecting service lines existing prior to reconstruction of a water main, as specified herein.

E. Inspection:

1. All water service installations, regardless of whether or not the service is located on private property or in public ROW, shall be inspected by the City Public Works Department prior to the Contractor backfilling the trench.
2. The Contractor shall notify the City Public Works Department a minimum of 24 hours prior to the time he needs the inspection.

3. Any trench backfilled without being inspected and approved by authorized City personnel shall be re-excavated by the Contractor to expose the work for the required inspection.
4. Discrepancies shall be corrected by the Contractor and re-inspected by City personnel.
5. Acceptance of Curb Stops and Main Valves:
  - a. As a condition for project acceptance, all curb stops and water main valves within the project boundaries shall be in proper operating condition.
  - b. City personnel will inspect and operate each curb stop and water main valve as part of the final inspection.
  - c. The Contractor shall correct any deficiencies discovered during the inspection.

#### 33.11.15.11 TESTING AND DISINFECTION

- A. Water service line joints shall be tested by turning on the corporation stop and applying main pressure to the service line before backfilling. Alternatively, the water service lines can be tested at the same time and at the same pressure as the water main.
- B. Disinfection of service lines shall be conducted in conformance with Section 03320 for water mains and at the same time the main line is disinfected unless otherwise approved by the Engineer. Testing for total coliform bacteria shall be performed by a State certified lab and performed in accordance with State requirements (at the time of testing).

### PRICE AND PAYMENT

#### 33.11.15.12 WATER SERVICE CONNECTION (if applicable)

- A. Measurement shall be by each installed.
- B. Basis of payment shall include tapping saddle, corporation stop, flushing, disinfection, testing, and all other appurtenances and tasks required to complete the work as specified.

#### 33.11.15.13 WATER SERVICE LINE

- A. Measurement shall be by the linear feet measured over the centerline of the pipe.
- B. Basis of payment shall include all pipe, fittings, flushing, disinfection, testing, and all other appurtenances required to complete the work as specified.

#### 33.11.15.14 WATER SERVICE CURB STOP

- A. Measurement shall be by each installed.
- B. Basis of payment shall include all pipe, fittings, flushing, disinfection, testing, and all other appurtenances required to complete the work as specified.
- ~~C. Basis of payment shall include all the meter pit assembly (meter pit, meter setter, backflow preventer, insulation, cover, and all necessary fittings), installation, elevation~~



~~and grade adjustments, cleanup, disinfection, testing, and all other appurtenances and work required to complete the work as specified.~~

#### 33.11.15.15 WATER SERVICE METER PIT

- A. Measurement shall be by each installed.
- B. Basis of payment shall include all the meter pit assembly (meter pit, meter setter, backflow prevention, insulation, cover, and all necessary fittings), installation, elevation and grade adjustments, cleanup, disinfection, testing, and all other appurtenances and work required to complete the work as specified.

**END OF SECTION**

## SECTION 33.11.50 – POTABLE WATER METER MANHOLE

### GENERAL

#### 33.11.50.01 SUMMARY

- A. Work covered by this section includes standard and shallow concrete manholes, for community water systems.
- B. Meter manhole(s) shall be constructed in accordance with the detailed drawings and unless specified otherwise on the Drawings or Specifications, the manhole(s) shall be constructed in accordance with precast concrete manholes as specified in Section 33.49.13.
- C. Meter manhole(s) shall be provided with steps.
- D. Flat cover slabs, when required, shall be designed for HS-20 loading and shall have an offset access hole in line with the manhole steps.
- E. Cones shall have an offset access hole in line with the manhole steps.

#### 33.11.50.02 RELATED WORK

- A. Section 03.05.13 – Concrete
- B. Section 31.23.16 – Excavation, Trenching and Backfill
- C. Section 33.11.13 – Potable Water Distribution
- D. Section 33.49.13 – Sanitary Sewer Manholes

#### 33.11.50.03 REFERENCES

- A. ASTM A48 – Standard Specification for Gray Iron Castings
- B. ASTM C443 – Standard Specification for Joints for Concrete Pipe and Manholes, Using Rubber Gaskets
- C. ASTM C478 – Standard Specification for Precast Reinforced Concrete Manhole Sections
- D. ASTM C923 – Standard Specification for Resilient Connectors Between Reinforced Concrete Manhole Structures, Pipes, and Laterals
- E. ASTM C990 – Standard Specification for Joints for Concrete Pipe, Manholes, and Precast Box Sections Using Preformed Flexible Joint Sealants
- F. ASTM C1244 – Standard Test Method for Concrete Sewer Manholes by the Negative Air Pressure (Vacuum) Test

#### 33.11.50.04 SUBMITTALS

- A. Manhole frames and covers w/Sensus SmartPoint installation
- B. Manhole steps
- C. Precast manhole sections & base section
- D. Joint sealing material
- E. Pipe to manhole connections
- F. Meters
- G. Meter supports
- H. Spools

#### 33.11.50.05 DEFINITIONS

- A. Shallow Manhole: Manholes with a depth from rim to outlet pipe invert equal to 7-feet or less, and with a flat top.
- B. Standard Manhole: Manholes with a depth from rim to outlet pipe invert greater than 7-feet but less than 8 -feet, and with a conical top section.

### PRODUCTS

#### 33.11.50.06 MANHOLES

- A. Design and fabricate reinforced concrete manholes to conform with Section 33.49.13, except as noted below.

#### 33.11.50.07 FRAMES AND COVERS

- A. Fabricate from cast iron.
  - 1. Clean and smooth.
  - 2. Free from distortion, shrinkage or other defects.
- B. Combined Weight (Frame, Lid, Inner Lid, and Lock Bar): 540 pounds, minimum.
- C. Conform to detail drawings.
- D. Frame (Frost Proof):
  - 1. Designed for use with covers without open pickholes.
  - 2. Machined, horizontal bearing surfaces.
  - 3. Equal to Neenah R-1755-E.
- E. Cover (Lid):
  - 1. Machined horizontal bearing surfaces.
  - 2. Neoprene ring gasket.
  - 3. Solid cover with concealed pickhole.
  - 4. Cast with lettering "WATER".

5. Cover shall be fitted with a 1.75" hole to accommodate a Sensus SmartPoint 520M radio transmitter. The hole location shall be included in the submittal.
6. Equal to Neenah R-1642.

#### 33.11.50.08 WATER METER

- A. The water meter shall be a Sensus OMNI Turbo (T<sup>2</sup>) in the size indicated in Drawings outfitted with a Sensus SmartPoint 520M radio transmitter mounted in the manhole cover.

#### 33.11.50.09 WATER METER SUPPORTS

- A. The water meters shall be supported by 4-inch min. galvanized steel pipes (2 per meter) fitted with a threaded steel flange on the bottom and a pipe saddle or clamp capable of securing the 8-inch meter housing at the support locations on the top.
- B. Each water meter support base flange shall be threaded forged steel and have four bolt holes. The bolt holes shall be ¾-inch and each flange shall be anchored, in an approved manner to the concrete floor with four 5/8-inch bolts with a 3-inch penetration into the concrete floor
- C. The pipe saddle or clamp shall be approved by the Engineer prior to installation.

#### 33.11.50.10 SPOOLS

- A. Each water meter vault manhole shall be provided with one fabricated pipe spool designed to exactly replace the installed meter in length and flange bolt pattern.
- B. The pipe rating shall be at least that of the highest rated piping used for connecting the new installation to the existing main.

### EXECUTION

#### 33.11.50.11 INSTALLATION

- A. Install reinforced concrete manholes to conform with Section 33.49.13, except as noted below.
- B. Joint Sealants:
  1. Install flexible joint gaskets around entire circumference of each manhole joint.
  2. Grout interior joints with non-shrink cement mortar grout or plastic cement putty.
  3. Ensure that a watertight seal is provided at the joint.
  4. Install exterior joint collars on all manhole joints, in accordance with manufacturer's recommendations.
- C. Frame and Cover:
  1. If a road finish grade exists, match manhole frames/covers to road finish grade.
  2. Set manhole frames and covers to the elevation indicated on the plans.
- D. Drain:

1. Install 4" cast iron drain, along with any necessary bends and w/floor grate.
2. If there is no convenient location to which to daylight drain then install a drainage pocket as follows (and route drain pipe to same):
  - a. Place a minimum of 1 cubic yard of crushed rock inside a wire cage at a location at least 6 inches below the bottom of the manhole gravel base and at least 2 feet outside the manhole footprint. The location is to be approved by the Project Engineer.
  - b. Install geotextile above the rock. The Project Engineer shall first approve the material to be used.

#### 33.11.50.12 PRESSURE AND LEAKAGE TESTING

- A. Test all manholes in accordance with Section 33.49.13.

### **PRICE AND PAYMENT**

#### 33.11.50.13 WATER METER VAULT MANHOLE

- A. Measurement: By each installed.
- B. Basis of Payment: For manholes up to 8 feet in depth, measured from the floor drainage invert to the top of the cover. Includes base, manhole sections, frame, cover, drainage forming, bedding, connections to existing main, outside gate valves, and all other appurtenances required to complete the work as specified.

#### 33.11.50.14 ADDITIONAL FEET OF MANHOLE

- A. Measurement: By the additional vertical foot of depth installed beyond 8 feet of depth, as measured from the floor drainage invert to the top of the cover.
- B. Basis of Payment: Includes manhole sections and all other appurtenances required to complete the work as specified.

### **END OF SECTION**

## **SECTION 33.31.13 – SANITARY SEWER MAIN**

### **GENERAL**

#### **33.31.13.01 SUMMARY**

- A. This section includes the construction of sanitary sewer mains, sewer main cleanouts, sewer line testing, and connection to existing sewage collection systems.

#### **33.31.13.02 RELATED WORK**

- A. Section 03.05.13 – Concrete
- B. Section 31.23.16 – Excavation, Trenching and Backfill
- C. Section 33.31.15 – Sanitary Sewer Service Lines
- D. Section 33.49.13 – Sanitary Sewer Manholes

#### **33.31.13.03 REFERENCES**

- ~~A. ANSI/AWWA C110 / A21.10 – Ductile Iron and Gray Iron Fittings, 3 Inch Through 48 Inch, for Water and Other Liquids~~
- ~~B. ANSI / AWWA C111 / A21.11 – Rubber Gasket Joints for Ductile Iron and Gray Iron Pressure Pipe Fittings~~
- ~~C. ANSI / AWWA C151 / A21.51 – Ductile Iron Pipe, Centrifugally Cast, for Water or Other Liquids~~
- D. ASTM D1248 – Polyethylene Plastics Molding and Extrusion Materials
- E. ASTM D2122 – Determining Dimensions of Thermoplastic Pipe and Fittings
- F. ASTM D3034 – Type PSM Polyvinyl Chloride (PVC) Sewer Pipe and Fittings
- G. ASTM D3212 – Joints for Drain and Sewer Plastic Pipes Using Flexible Elastomeric Seals
- H. ASTM F477 – Elastomeric Seals (Gaskets) for Joining Plastic Pipe
- I. ASTM F1417 – Installation Acceptance of Plastic Gravity Sewer Lines Using Low-Pressure Air

#### **33.31.13.04 SUBMITTALS**

- A. Sewer Main Pipe.
- B. Frame and Cover for Sewer Main Cleanouts.

### 33.31.13.05 ACCEPTANCE

- A. The work will not be accepted until satisfactory pipe backfilling, testing, and cleanup is complete.
- B. If the Work does not meet the specified requirements of this section and related sections, remove, replace, and retest at no additional cost.

## PRODUCTS

### 33.31.13.06 SEWER PIPE

#### A. Polyvinyl Chloride (PVC) Sewer Pipe

- 1. PVC pipe shall conform to ASTM D3034.
- 2. PVC pipe shall be class SDR-35.
- 3. Bell end joints shall conform to ASTM D3212.
- 4. Elastomeric gaskets shall conform to ASTM F477.
- 5. Each length of pipe shall be clearly marked with the following:
  - a. Manufacturer,
  - b. Nominal Pipe Size,
  - c. The PVC Cell Classification,
  - d. Type PSM PVC Sewer Pipe,
  - e. ASTM Designation, and
  - f. Pipe Class.

#### ~~B. Ductile Iron DI Sewer Pipe~~

- ~~1. DI pipe shall conform to AWWA C151.~~
- ~~2. DI pipe shall be thickness class 50.~~
- ~~3. Exterior coating shall be asphaltic, 1 mil thick, minimum.~~
- ~~4. Rubber-gasket, push-on joints shall conform to ASTM C111.~~
- ~~5. Interior lining shall be calcium aluminate mortar (minimum 125 mils thick) or ceramic epoxy (minimum 40 mils thick), fusion bonded.~~
- ~~6. Each length of pipe shall be clearly marked with the following:
  - ~~a. Manufacturer,~~
  - ~~b. Nominal Pipe Size,~~
  - ~~c. ASTM Designation, and~~
  - ~~d. Pipe Class.~~~~

#### C. Polypropylene (PP) Sewer

- 1. PP pipe shall conform to ASTM F2764.
- 2. PP pipe shall have a minimum pipe stiffness of 46 pii when tested in accordance with ASTM D2412.
- 3. The joint shall be watertight according to the requirements of ASTM D3212, with the addition of a 15 psi pressure requirement.
- 4. Two gaskets installed shall meet the requirements of ASTM F477.
- 5. Fittings shall conform to ASTM F2764.
- 6. Each length of pipe shall be clearly marked with the following:
  - a. Manufacturer,
  - b. Nominal Pipe Size,
  - c. ASTM Designation.

### 33.31.13.07 SEWER APPURTENANCES

- A. Manholes
  - 1. Refer to Section 33.49.13.
- B. Sewer Main Cleanouts
  - 1. Cleanout riser pipe shall conform to ASTM D3034.
  - 2. Cleanout pipe shall be class SDR-35.
  - 3. Elastomeric gasket joints shall conform to ASTM D3212.
  - 4. Cleanout piping shall be the same diameter as the main piping unless otherwise specified.
  - 5. The riser shall be fitted with a gasketed, air-tight plug of the same diameter.
  - 6. The upper terminus shall be provided with a concrete collar in accordance with the details. Refer to Section 03.05.13 for cast-in place concrete requirements.
  - 7. The cleanout shall be provided with a protective frame and cover as follows:
    - a. The frame and cover shall be the heavy-duty slab type.
    - b. The frame and cover shall have machined bearing surfaces.
    - c. The frame shall be fitted with a neoprene gasket seal.
    - d. The cover shall be lockable with stainless steel bolts.
    - e. The frame and cover shall be Neenah R-6461-CH, or equal.

## EXECUTION

### 33.31.13.08 CONTINUITY OF SERVICE

- A. The Contractor shall provide continuous, uninterrupted sanitary sewer service to all users in and upstream of the project area.
- B. Flow Handling Plan
  - 1. Prior to beginning work on any manhole or sewer main requiring flow modification the Contractor shall present a plan for handling wastewater flows to the Engineer for his approval.
  - 2. The plan shall describe the methods to be used and shall identify all materials and equipment that will be required for flow handling.
  - 3. The Contractor's plan shall also identify a contingency plan and procedures to be implemented in the event of an equipment failure or other emergency.
- C. Methods
  - 1. Bypass pumping is required during construction hours and temporary connections, between existing and new sewer mains are required during nonworking hours.
  - 2. Wastewater flows shall not be conveyed in open ditches nor in the trench excavation, and at no time shall wastewater be allowed on the ground surface, streets, gutters, storm sewers, or other places, which may constitute a health hazard.
- D. Health Hazards
  - 1. Whenever, in the opinion of the Engineer, a health hazard exists because of actions or inactions of the Contractor, the Contractor shall immediately correct the situation to the satisfaction of the Engineer.
  - 2. If not corrected in a timely manner, the City may cause to take any actions necessary to remove the health hazard and charge the Contractor one and a half (1 ½) times the cost incurred.



E. Damages to Property

1. Any damages to private or public property due to backups, overflows, or surcharging resulting from work under this section shall be the responsibility of the Contractor and shall be corrected as soon as practical and at no cost to the City.
2. If not corrected in a timely manner, the City will take the necessary action and charge the Contractor one and a half (1 ½) times the cost incurred.

33.31.13.09 EXAMINATION

- A. Verify that dimensions and elevations are as indicated on the plans.
- B. Verify that all products are in new condition.
- C. Inspect pipe and fittings for defects.
- D. Remove materials from the site that are defective, damaged, used, unsound, or that otherwise do not meet the specifications.

33.31.13.10 UTILITY CONFLICTS

- A. Refer to Section 31.23.16.

33.31.13.11 SEWER MAIN INSTALLATION

A. Pipe Installation

1. Adhere to the excavation, trenching and backfill requirements of Section 31.23.16.
2. Install pipe and fittings in accordance with these specifications and the manufacturer's recommendations.
3. Lay pipe of the size, and to the line and grade indicated on the drawings.
4. Ensure vertical alignment does not deviate more than ½ inch from the design grade as shown on the plans.
5. Ensure horizontal alignment does not deviate more than 1 inch from the design as shown on the plans.
6. Install pipe beginning at the lowest elevation and proceeding to the highest elevation.
7. Point the spigot end in the direction of flow.
8. Protect pipe interior from soil, trench water and foreign objects.
9. Temporarily plug the exposed end of pipes whenever the trench is left unattended or when trench conditions necessitate.

B. Connection to Existing Manholes

1. Make connection in conformance with Section 33.49.13.

C. Sewer Main Cleanouts

1. Install at the locations indicated on the plans.
2. Construct as shown on the standard detail drawing.

33.31.13.12 ABANDONMENT

A. Sewer Main Abandonment

1. Existing Sewer Mains to be abandoned between manholes shall be plugged at all open ends with concrete extending into the abandoned pipe one foot or one pipe diameter, whichever is greater.
2. Existing sewers to be abandoned at a manhole shall be cut flush with the inside of the manhole and plugged as specified above.
3. The pipe shall be grouted flush with the inside of the manhole and the manhole invert shall then be reconstructed.
4. The reconstructed manhole inverts shall provide for the new flow scheme and comply with the standards for manhole inverts, as specified.
5. The completed manhole shall be watertight, and the inverts shall be smooth and uniform.

B. Manhole Abandonment

1. Refer to Section 33.49.13.

33.31.13.13 SEWER MAIN TESTING

A. General

1. Furnish all materials, labor and equipment to perform the required tests.
2. Perform all tests in the presence of the Project Engineer or his/her representative.
3. Repair all sections not passing the tests, at no cost to the contract.
4. Retest sewer until tests pass the requirements, at no cost to the contract.

B. Pre-Cleaning

1. Prior to testing newly installed sewer pipe, the Contractor shall remove all accumulated construction debris, rock, gravel, sand, silt, and other foreign matter from the sewer with an appropriately sized cleaning ball.
2. The Contractor shall be responsible for all work necessary to make the sewer acceptable for usage including removal of all mud, silt, rocks, or blockages that make said sewer unacceptable for final acceptance and usage.
3. Also included is all work necessary in the manholes and all cleanup work required prior to final acceptance.

C. Deflection Test

1. Perform the deflection test on all new sewer main.
2. Testing Device:
  - a. Use a mandrel, or some other Project Engineer approved rigid, cylindrical object of proper dimensions.

Nominal Pipe Size I.D. (inches)	Length (A) (inches)
8	8
10	10
12	10
15	12

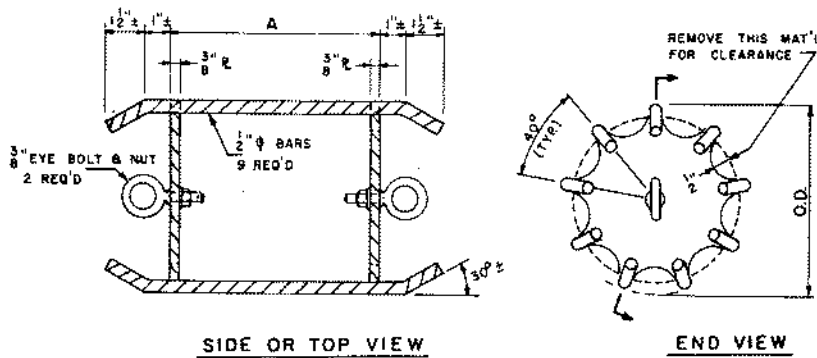

- b. Tests Within 30 Days of Installation: Mandrel outside diameter shall be equal to 95% of the sewer main inside diameter.
- c. Tests Beyond 30 Days of Installation: Mandrel outside diameter shall be equal to 92.5% of the sewer main inside diameter.
3. To be considered a successful test, the mandrel shall pass through the entire length of sewer main in one pass without mechanical force.

#### D. Air Test

1. All gravity sewers and appurtenances shall successfully pass a low-pressure air test prior to acceptance.
2. Preparation:
  - a. Clean all sewer pipe before the test.
  - b. Testing Equipment:
    - i. Plugs: mechanical or pneumatic type. One shall have an inlet tap for adding air to the sewer line.
    - ii. Air Compressor.
    - iii. Main Shutoff Valve.
    - iv. Pressure Relief Valve: 9 psig relief.

- v. Input Pressure Gauge.
  - vi. Continuous Monitoring Pressure Gauge: Minimum divisions of 0.10 psi with an accuracy of +/- 0.04 psi.
3. Testing Procedure:
- a. Test according to the Time-Pressure Drop Method outlined in ASTM F1417.
  - b. Plug all pipe outlets with test plugs capable of holding under the test pressures.
  - c. Install plugs and brace as necessary to ensure that the plugs will not blow out when the main is under pressure.
  - d. Inspect sewer main pipe integrity in the area that will not be tested due to the plug, and report any possible defects to the Project Engineer.
  - e. Ensure test apparatus and gauges are accessible to Owner's representative without entry into the manhole.
  - f. Pressurize Pipe:
    - i. Introduce air slowly until air pressure reaches 4.0 psig greater than any backpressure resulting from groundwater over the pipe, where the pressure equals 4.0 psi + (0.43 psi X Depth of Groundwater over Pipe Invert in Feet).
    - ii. Never exceed a pressure of 9.0 psig.
    - iii. Do not enter manhole once pipe is pressurized.
    - iv. Maintain pressure for at least two (2) minutes.
    - v. Disconnect air supply after the initial two (2) minutes have passed.
    - vi. Adjust pressure to test pressure.
    - vii. Decrease air pressure to 3.5 psig greater than any pressure resulting from groundwater over the pipe, where the test pressure equals 3.5 psi + (0.43 psi X Depth of Groundwater over Pipe Invert in Feet).
  - g. Determine elapsed time for the pressure to drop 1.0 psig and use Table 1, or determine the elapsed time for the pressure to drop 0.5 psig from the test pressure and use Table 2.
  - h. The time interval recorded in the field must be greater than the time listed for the pipe length and diameter being tested and the pressure drop recorded.
  - i. If the pressure drop time is less than that in the appropriate table, for the pipe diameter and the length being tested, the test shall be considered failed.
  - j. No variance in the time allowances shall be granted for the fact that sewer service lines have been installed.
  - k. Individual service lines need not be tested unless otherwise specified.
  - l. In lieu of low-pressure air testing of the sewer system, the Project Engineer may approve a hydrostatic exfiltration testing procedure to test the lines.
  - m. Approval of the procedure, equipment and basis of acceptance for this testing method will be sent in writing by the Engineer prior to the initiation of testing.

TABLE 1: Minimum Specified Time Required for a 1.0 psig Pressure Drop

Pipe Dia. (in.)	Min. Time (min:sec)	100 Feet	150 Feet	200 Feet	250 Feet	300 Feet	350 Feet	400 Feet	Time for Longer Pipe Lengths (Seconds)
4	3:46	3:46	3:46	3:46	3:46	3:46	3:46	3:46	.380*L
6	5:40	5:40	5:40	5:40	5:40	5:40	5:40	5:42	.854*L
8	7:34	7:34	7:34	7:34	7:34	7:36	8:52	10:08	1.520*L
10	9:26	9:26	9:26	9:26	9:53	11:52	13:51	15:49	2.374*L
12	11:20	11:20	11:20	11:24	14:15	17:05	19:56	22:47	3.418*L
15	14:10	14:10	14:10	17:48	22:15	26:42	31:09	35:36	5.342*L

18	17:00	17:00	19:13	25:38	32:03	38:27	44:52	51:16	7.692*L
----	-------	-------	-------	-------	-------	-------	-------	-------	---------

TABLE 2: Minimum Specified Time Required for a 0.5 psig Pressure Drop

Pipe Dia. (in.)	Min. Time (min:sec)	100 Feet	150 Feet	200 Feet	250 Feet	300 Feet	350 Feet	400 Feet	Time for Longer Pipe Lengths (Seconds)
4	1:53	1:53	1:53	1:53	1:53	1:53	1:53	1:53	.190*L
6	2:50	2:50	2:50	2:50	2:50	2:50	2:50	2:51	.427*L
8	3:47	3:47	3:47	3:47	3:47	3:48	4:26	5:04	.760*L
10	4:43	4:43	4:43	4:43	4:57	5:56	6:55	7:54	1.187*L
12	5:40	5:40	5:40	5:42	7:08	8:33	9:58	11:24	1.709*L
15	7:05	7:05	7:05	8:54	11:08	13:21	15:35	17:48	2.671*L
18	8:30	8:30	9:37	12:49	16:01	19:14	22:26	25:38	3.846*L

E. Ex-filtration Test

1. This test shall be used in those instances where further testing is required, at the discretion of the Engineer, and the air test is not feasible or practical or as a follow-up to another test method, and the minimum ground water level above the top of the highest test pipe section is less than 2 feet.
2. The infiltration test shall be made in a manner approved by and in the presence of the Engineer, or designee.
3. The test shall provide a minimum head of two (2) feet at the highest point in the test section, but no more than 10 feet of head at the lowest point, with head measured from top of pipe.
4. Unless otherwise specified, the pipe shall not allow ex-filtration of water of more than 50 gallons per inch diameter per mile of pipe (50 gal./in./mi.) in any 24-hour period in accordance with the table below.

Diameter of Sewer (inches)	Leakage Rate (gallons/ft/24 hr)
8	0.08 x L (ft)
10	0.09 x L (ft)
12	0.11 x L (ft)
15	0.14 x L (ft)
18	0.17 x L (ft)
21	0.20 x L (ft)
24	0.23 x L (ft)

5. The minimum test period shall be for two (2) hours and the values derived from Table 9–2 will need to be adjusted for the actual test time.
6. If the test section fails to meet these requirements, the Contractor shall, at his own expense, determine the source of leakage, repair or replace all deficiencies, and retest the installation, all in a manner approved by the Engineer.
7. The Contractor shall anticipate the need to conduct multiple tests in order to meet the above requirements and shall conduct testing in such a manner and sequence that the requirements indicated above are achieved.
8. Water used to test ex-filtration shall be clean potable water.

9. Upon completion of the test, if the Contractor desires to discharge the water to the sewer system and the Engineer has no objection, the Contractor shall contact the wastewater treatment plant manager and request permission for same. If such permission is granted the discharge shall be allowed.

F. Infiltration Test

1. This test shall be used in those instances where further testing is required, at the discretion of the Engineer, and the air test is not feasible or practical or as a follow-up to another test method, and the minimum ground water level above the top of the highest test pipe section is 2 feet.
2. The infiltration test shall be made in a manner approved by and in the presence of the Engineer, or designee.
3. Maximum allowable infiltration is 200 gallons per day per inch diameter per mile of sewer line **and** the infiltration between any two adjacent manholes shall not be greater than 250% of the allowable infiltration rate.

Diameter of Sewer (inches)	Infiltration per foot per hour (gallons)
4	0.0063
6	0.0095
8	0.0126
10	0.0158
12	0.0190
15	0.0237
18	0.0284
21	0.0331
24	0.0379

4. Infiltration allowance for manholes is computed using the total number of vertical feet of manhole expressed as the equivalent diameter sewer.

Diameter of Manhole (inches)	Infiltration per vertical foot per hour (gallons)
42	0.0663
48	0.0758

5. All gravity sewers and appurtenances shall be free of visible leakage and all such leaks shall be corrected.
6. Infiltration of groundwater in an amount greater than specified, following a successful air test shall be considered as evidence that the air test was in error or that subsequent failure of the pipelines has occurred.
7. Failures which occur within the warranty period shall be corrected at no additional expense to the project.

G. Video Inspection

1. A video inspection shall be performed on all new sewer main, including manholes.
2. The video inspection shall consist of viewing the inside of all sewer main pipe installed to determine proper alignment, joining, properly installed service connections, infiltration, etc.
3. The Contractor shall correct, at his own expense, any defects, including areas of infiltration, discovered during the video inspection.

4. The expense of the video inspection shall be borne entirely by the Contractor.
5. If defective workmanship of material or construction is noted, the Contractor, at no expense to the City, shall correct the deficiency and provide another video inspection to verify the work was satisfactorily corrected.
6. The Contractor shall be responsible for all related inspection and repair costs, including any necessary concrete or asphalt removal and/or resurfacing.

## **PRICE AND PAYMENT**

### **33.31.13.14 SEWER MAIN**

- A. Measurement shall be by the linear feet measured over the centerline of the pipe.
- B. Basis of payment shall include all pipe, fittings, flushing, testing, and all other appurtenances required to complete the work as specified.

### **33.31.13.15 SEWER MAIN CLEANOUT**

- A. Measurement shall be by each installed.
- B. Basis of payment shall include all sewer wye, riser pipe, fittings, concrete, frame, cover, and all other appurtenances required to complete the work as specified.

## **END OF SECTION**

## SECTION 33.31.15 – SANITARY SEWER SERVICE LINES

### GENERAL

#### 33.31.15.01 SUMMARY

- A. This section includes the construction of sanitary sewer service lines, sewer service cleanouts, sewer service line testing, and connection to existing sewage collection systems.
- B. Sanitary sewer service lines are the lines from the sewer main to within five (5) feet of the building and are owned and maintained by the owner of the property being served.

#### 33.31.15.02 RELATED WORK

- A. Section 03.01.13 – Concrete
- B. Section 31.23.16 – Excavation, Trenching and Backfill
- C. Section 33.31.13 – Sanitary Sewer Main
- D. Section 33.49.13 – Sanitary Sewer Manholes

#### 33.31.15.03 REFERENCES

- A. ANSI/AWWA C110 / A21.10 – Ductile-Iron and Gray-Iron Fittings, 3 Inch Through 48 Inch, for Water and Other Liquids
- B. ANSI / AWWA C111 / A21.11 – Rubber Gasket Joints for Ductile-Iron and Gray-Iron Pressure Pipe Fittings
- C. ANSI / AWWA C151 / A21.51 – Ductile Iron Pipe, Centrifugally Cast, for Water or Other Liquids
- D. ASTM D1248 – Polyethylene Plastics Molding and Extrusion Materials
- E. ASTM D2122 – Determining Dimensions of Thermoplastic Pipe and Fittings
- F. ASTM D3034 – Type PSM Polyvinyl Chloride (PVC) Sewer Pipe and Fittings
- G. ASTM D3212 – Joints for Drain and Sewer Plastic Pipes Using Flexible Elastomeric Seals
- H. ASTM F477 – Elastomeric Seals (Gaskets) for Joining Plastic Pipe

#### 33.31.15.04 SUBMITTALS

- A. Sewer Service Pipe
- B. Sewer Service Appurtenances



C. Tracer Wire and accessories

33.31.15.05 ACCEPTANCE

- A. The work will not be accepted until satisfactory pipe backfilling, testing, and clean-up is complete.
- B. If the Work does not meet the specified requirements of this section and related sections, remove, replace, and retest at no additional cost.

**PRODUCTS**

33.31.15.06 SEWER PIPE

A. Polyvinyl Chloride (PVC) Sewer Pipe:

- 1. PVC pipe shall conform to ASTM D3034.
- 2. PVC pipe shall be class SDR-35.
- 3. Bell end joints shall conform to ASTM D3212.
- 4. Elastomeric gaskets shall conform to ASTM F477.
- 5. Each length of pipe shall be clearly marked with the following:
  - a. Manufacturer,
  - b. Nominal Pipe Size,
  - c. The PVC Cell Classification,
  - d. Type PSM PVC Sewer Pipe,
  - e. ASTM Designation, and
  - f. Pipe Class.

~~B. Ductile Iron DI Sewer Pipe:~~

- ~~1. DI pipe shall conform to AWWA C151.~~
- ~~2. DI pipe shall be thickness class 50.~~
- ~~3. Exterior coating shall be asphaltic, 1 mil thick, minimum.~~
- ~~4. Rubber gasket, push-on joints shall conform to ASTM C111.~~
- ~~5. Interior lining shall be calcium aluminate mortar (minimum 125 mils thick) or ceramic epoxy (minimum 40 mils thick), fusion bonded.~~
- ~~6. Each length of pipe shall be clearly marked with the following:
  - ~~a. Manufacturer,~~
  - ~~b. Nominal Pipe Size,~~
  - ~~c. ASTM Designation, and~~
  - ~~d. Pipe Class.~~~~

C. Polypropylene (PP) Sewer Pipe

- 1. PP pipe shall conform to ASTM F2764.
- 2. PP pipe shall have a minimum pipe stiffness of 46 pii when tested in accordance with ASTM D2412.
- 3. The joint shall be watertight according to the requirements of ASTM D3212, with the addition of a 15 psi pressure requirement.
- 4. Two gaskets installed shall meet the requirements of ASTM F477.
- 5. Fittings shall conform to ASTM F2764.
- 6. Each length of pipe shall be clearly marked with the following:
  - a. Manufacturer,
  - b. Nominal Pipe Size,

- c. ASTM Designation.

#### 33.31.15.07 SEWER APPURTENANCES

##### A. Sewer Service Line Cleanouts:

1. Cleanout riser pipe shall conform to ASTM D3034.
2. Cleanout pipe shall be class SDR-35.
3. Elastomeric gasket joints shall conform to ASTM D3212.
4. Cleanout piping shall be the same diameter as the main piping unless otherwise specified.
5. The riser shall be fitted with a gasketed, air-tight plug of the same diameter.
6. The upper terminus shall be provided with a concrete collar in accordance with the details. Refer to Section 03.05.13 for cast-in place concrete requirements.

#### 33.31.15.08 TRACER WIRE

##### A. Wire:

1. Provide #10 AWG jacketed solid copper wire, type THHN/THWN.

##### B. Box:

1. Provide adjustable tracer wire access box manufactured by C.P. Test Services - Valvco, Inc or equal.

##### C. Splice Kit:

1. Provide underground waterproof splice materials.

### EXECUTION

#### 33.31.15.09 EXAMINATION

- A. Verify that dimensions and elevations are as indicated on the plans.
- B. Verify that all products are in new condition.
- C. Inspect pipe and fittings for defects.
- D. Remove materials from the site that are defective, damaged, used, unsound, or that otherwise do not meet the specifications.

#### 33.31.15.10 UTILITY CONFLICTS

- A. Refer to Section 31.23.16.
- B. Horizontal distance between sewer service and water service lines shall not be less than ten (10) feet.

#### 33.31.15.11 SEWER SERVICE LINE INSTALLATION

##### A. Pipe Installation:

1. Adhere to the excavation, trenching and backfill requirements of Section 31.23.16.
2. Install pipe and fittings in accordance with these specifications and the manufacturer's recommendations.

3. Lay pipe of the size, and to the line and grade indicated on the drawings.
4. Service pipe shall be laid at a minimum slope of 1/8 inch per foot or as per plans.
5. Minimum depth of cover over service lines shall be 3 1/2 feet.
6. Install pipe beginning at the lowest elevation and proceeding to the highest elevation.
7. Point the spigot end in the direction of flow.
8. Protect pipe interior from soil, trench water and foreign objects.
9. Temporarily plug the exposed end of pipes whenever the trench is left unattended or when trench conditions necessitate.
10. Cleanouts shall be installed at all changes in horizontal alignment of greater than 45° and at distances not to exceed 75 feet for 4-inch diameter pipe and 100 feet for 6-inch diameter pipe.
11. Cleanout location and installation shall meet the more stringent of the above requirements of those of the adopted plumbing code.
12. Insulation for sewer services, when shown on the drawings, shall be as specified for sewer mains.
13. Wrap ductile iron pipe with 8 mil polyethylene encasement, according to manufacturer's recommendations.

B. Sewer Service New Connections:

1. Where new service lines are to be installed for undeveloped property or future buildings, the Contractor shall furnish all materials necessary for connection of new service lines to the sewer main.
2. The Contractor shall obtain and pay permits and tapping fees as established by ordinance.
3. In-line tees may be used in lieu of saddles for 4-inch and 6-inch service lines. The use of an in-line service tee does not waive any tapping fees or the City inspection requirements.
4. In-line tees shall be furnished and installed by the Contractor as the sewer main is installed.
5. New service connections and lines shall be, at a minimum, extended to the property line and the service line capped.
6. The termination point shall be marked in one of two ways as follows:
  - a. If there is limited risk of the marker being damaged, destroyed, or removed:
    - i. A 2" x 4" treated wood stud long shall be utilized.
    - ii. The stud shall be long enough to extend from the depth of the service line connection to the main to 2 feet above finished grade.
    - iii. The stud shall be located no more than 12 inches from a line extended from the service connection stub.
  - b. If the marker needs to be buried:
    - i. A minimum 3-foot long steel fence post shall be utilized.
    - ii. The steel fence post shall be buried vertically plumb below the surface at least 8 inches and above the end of the service connection stub.
    - iii. The base of the post shall be at least 6" above the top of the stub piping.
    - iv. The post needs to be steel to facilitate location by magnetic locators.
7. City personnel shall inspect all taps of City sewer mains.
8. The Contractor shall schedule all service taps between 7:30 AM to 3:00 PM, Monday through Friday.

C. Sewer Service Reconnections:

1. The Contractor shall furnish all materials necessary for reconnecting service lines existing prior to reconstruction of a sewer main.
2. In-line tees may be used in lieu of saddles for 4-inch and 6-inch service lines.
3. The use of an in-line service tee does not waive any tapping fees or the City inspection requirements.
4. In-line tees shall be furnished and installed by the Contractor as the sewer main is installed.
5. The Contractor shall visually inspect the inside of each existing sewer service line to be connected to the new sewer main prior to making the reconnection.
6. When it is discovered that an existing sewer service line beyond the edge of the excavation is not in good physical condition or is plugged, full of roots, or is otherwise not operating properly, the Contractor shall notify the Engineer so he may document the condition and notify the property owner.
7. Connections between the new service line and existing service line shall be accomplished with a gasketed bell or reinforced Fernco-type coupling.
8. City personnel shall tap all City sewer mains inspect all sewer taps.
9. The Contractor shall schedule all service taps between 7:30 AM to 3:00 PM, Monday through Friday.
10. Abandoning of service lines shall be accomplished by cutting and plugging the line at the sewer main unless directed otherwise by the City Engineer. The service line shall be plugged in the same manner as specified for plugging sewer mains.

D. Connection to Existing Manholes:

1. Make connection in conformance with Section 33.49.13.

~~E. Sewer Main Cleanouts:~~

- ~~1. Install at the locations indicated on the plans.~~
- ~~2. Construct as shown on the standard detail drawing.~~

33.31.15.12 TRACER WIRE INSTALLATION

A. Tracer wire shall be installed along with all sewer lines as described below:

1. The tracer wire shall be extended with the service line.
2. The wire shall be installed along the top of the pipe and shall be securely anchored to the pipe every 4 feet horizontally with an adhesive tape.
3. The tracer wire shall be brought to the surface at each clean out and shall terminate at the service connection point on the main.
4. At locations where the service line is not being replaced entirely, the Contractor will splice the new tracer wire to the existing tracer wire at the point of reconnection.
5. In instances where a service line is not being replaced entirely and the existing tracer wire is not encountered, the Contractor shall coil approximately five feet of wire at the reconnection location(s) to facilitate a future splice.
6. All tracer wire connections shall be accomplished with "pig-tails."
7. All splices and "pig-tails" shall be accomplished by stripping the wires to be connected, twisting the wires together, securing the connections by using an appropriately sized wire nut, and preserving the splice or "pig-tail" by using a direct bury splice kit.

33.31.15.13 INSPECTION

- A. All sewer service installations and abandonments shall be inspected by the City Utility Maintenance Division, prior to backfilling.
- B. The Contractor shall notify the City a minimum of twenty-four (24) hours prior to the time of the inspection.
- C. Any trench backfilled without being inspected and approved by authorized City personnel shall be re-excavated by the Contractor to expose the work for the required inspection.
- D. Discrepancies shall be corrected by the Contractor and re-inspected by City personnel.

## **PRICE AND PAYMENT**

### **33.31.15.14 SEWER SERVICE LINE**

- A. Measurement shall be by the linear feet measured over the centerline of the pipe.
- B. Basis of payment shall include all pipe, fittings, flushing, testing, and all other appurtenances required to complete the work as specified.

### ~~33.31.15.15 SEWER MAIN CLEANOUT~~

- ~~A. Measurement shall be by each installed.~~
- ~~B. Basis of payment shall include all sewer wye, riser pipe, fittings, concrete, and all other appurtenances required to complete the work as specified.~~

**END OF SECTION**

## **SECTION 33.31.20 – SANITARY SEWER MAIN CLEANING AND INSPECTION**

### **GENERAL**

#### **33.31.20.01 SUMMARY**

- A. This section includes methods of inspecting sewers is to obtain information that will allow for the assessment of their conditions.
- B. Unless specified otherwise by the Engineer, the purpose of cleaning sewers is to facilitate the inspection of sewers as specified by the Engineer.
- C. Sewers shall be cleaned to the extent required within these specifications, using methods allowed in these Specifications and chosen by the Contractor.

#### **33.31.20.02 SCOPE**

- A. Sewer cleaning and inspection shall include, but not be limited to, the following:
  - 1. locating manholes,
  - 2. construction of access corridors for personnel and equipment including the removal of obstructions and the stabilization of surfaces,
  - 3. making manholes accessible,
  - 4. control of flows when needed to facilitate sewer cleaning and inspection operations,
  - 5. provision of water necessary for sewer and manhole cleaning operations,
  - 6. cleaning of sewers,
  - 7. cleaning of manholes adjoining sewers to be cleaned,
  - 8. disposal of materials collected as part of sewer cleaning operations,
  - 9. inspection of sewers, and the
  - 10. production of information resulting from sewer inspection operations, including the creation, management and distribution of files and reports.
- B. It shall be understood that all other tasks not explicitly listed above but required to complete sewer cleaning and inspection operations are included in the scope thereof.

#### **33.31.20.03 SUBMITTALS**

- A. Plan for completion of work, including method(s), equipment to be used, cleaning waste collection and disposal, starting point and progression plan.
- B. Schedule for completion of work (and any updates to same).
- C. Any materials planned for use in completion of the project.
- D. One hard copy of all printable material and one electronic copy of all cleaning and inspection video and note files.

## EXECUTION

### 33.31.20.04 GENERAL

- A. All sewer main to be inspected shall first be cleaned and then inspected by closed circuit television (CCTV).
- B. It will be the Contractor's responsibility to ensure all pipeline can be fully inspected.

### 33.31.20.05 SEWER AND MANHOLE CLEANING

#### A. General

- 1. Where specified by the Engineer, sewers and manholes shall be cleaned such that 95% of the combination of materials foreign to the collection system and those not attached to the same are removed from the sewer collection system.
- 2. Materials to be removed from sewers and manholes to be cleaned shall include, but not be limited to, sludge, mud, sand, rocks, stones, gravel, pebbles, bricks, solidified fats, solidified oils, solidified grease, pieces of broken pipe, root intrusions, hardened debris and deposits.
- 3. Only when directed by the Engineer, and in accordance with these Specifications, protruding service connections shall be removed.
- 4. Unless specified otherwise by the Engineer, the Contractor shall make arrangements for obtaining water for sewer cleaning.
- 5. If cleaning of an entire sewer, from manhole to manhole, cannot be successfully completed from either its upstream or downstream terminus, cleaning of the sewer shall be attempted from the opposite access structure, if accessible; however, if the Contractor believes that such a reverse set-up might result in the involuntary discharge of flows from the sewer collection system, then sewer cleaning from the opposite access location might be excused by the Engineer and continued cleaning efforts abandoned.

#### B. Cleaning Equipment

- 1. Sewers and manholes shall be cleaned both in accordance with these Specifications and using hydraulically-powered, mechanically-powered, or robotically-controlled equipment.
  - a. Hydraulically-powered Sewer Cleaning Equipment:
    - i. Hydraulically-powered sewer cleaning equipment shall be capable of producing a range of scouring velocities sufficient to clean sewers as specified without causing involuntary discharge of flows from the sewer collection system.
    - ii. When using hydraulic cleaning equipment, care shall be taken when accessing a sewer from an upstream manhole where it is known that connections are present. In such situations, the scouring velocity of the cleaning water shall be reduced to avoid causing damage to property upstream of connections.

- iii. When using hydraulic cleaning equipment from a downstream manhole, care shall be taken to avoid depositing solids in connections that might occur during the propelling of the cleaning head and hose upstream.
  - iv. The Contractor shall also have available a high-pressure, hand gun system to allow for washing and scouring all components of a manhole including corbels, walls, troughs, and inverts. The gun shall also be capable of producing a range of water pressures both sufficient enough to completely clean designated manholes to the level specified yet gentle enough not to displace existing manhole components.
  - v. Removal of foreign materials from sewers may be accomplished by physically impacting the materials with either hydraulically-driven chain cutters or hydraulically-driven, rotating saws. When using such an impact device, care shall be taken by the Contractor to avoid damage to sewers. To minimize the risk, and severity, of such damage the Contractor shall only use chain cutters in conjunction with inspection equipment so that the chain-cutting operations can be continuously monitored.
- b. Mechanically-powered Sewer Cleaning Equipment:
    - i. Sewer-cleaning equipment powered by mechanical devices such as winches shall be allowed. "Bucket" machines are one such example.
    - ii. When using cabled equipment such as winches, the Contractor shall exercise precautions to avoid damage to the sewer collection system.
  - c. Robotically-controlled Sewer Cleaning Equipment:
    - i. Robotically- (remotely-) controlled cleaning equipment (e.g., cutters and grinders) shall be normally be allowed, but is subject to the approval of the Engineer.

#### C. Material Removal

1. During, or immediately after completion of, sewer cleaning operations, all materials resulting from sewer cleaning operations shall be removed from the sewer being cleaned.
2. Neither passing material from one sewer to another nor accumulations of materials in structures shall be permitted. Both upstream and downstream manholes are to be cleaned as the respective sewer is cleaned.
3. All materials resulting from the cleaning operations shall be removed from the site and disposed of by the Contractor.
4. The Contractor shall not be allowed to accumulate and store materials overnight at the site(s) of work except in totally enclosed containers approved by the Engineer.
5. Normal domestic sewage collected by the Contractor as part of the completion of this project can be disposed of by the Contractor at a location approved by the Engineer.
6. The Contractor shall be responsible for all transport and disposal fees.

#### D. Root Removal

1. Only that equipment described above shall be allowed for the removal of the roots from sewers; no chemical removal methods may be used.
2. All sewers that require root removal will be both cleaned and inspected in their entirety after root removal is completed.



3. While root removal operations are being executed, inspection recordings may be paused and continued after root removal is complete such that the inspection recording of the whole of sewers is contained within one electronic file.

#### E. Protruding Service Connections

1. Removal of protruding service connections shall be performed by the Contractor when such connections either do not permit the passing of the inspection camera or, in the opinion of the Engineer, might be problematic in the performance of future sewer repairs.
2. Protruding service connections shall be removed using equipment referenced above to within ½ inch of the interior surface of the host sewer.
3. The removal of protruding service connections shall be completed without breaking protruding service connections, creating jagged edges on remaining service connections or removing service connections beyond the limits specified above.
4. Any sewer in which a protruding service connection is removed shall be subsequently cleaned and inspected in its entirety after the protruding service connection is removed.

#### F. Special Circumstances

1. It is recognized that situations will occur where further sewer cleaning, or a particular method of cleaning, is undesirable. Examples of such a situation might be:
  - a. the discovery of a sewer that is in advanced stages of deterioration and further deterioration is likely if sewer cleaning continues, or
  - b. when poor hydraulics within a sewer limits the methods able to be used to clean the system out of concern of involuntarily discharging flows from the collection system.
2. If the Contractor formally informs the Engineer of a discovered potential defect in a sewer that may prevent further sewer cleaning, the Contractor shall safely inspect as much of the sewer in question as possible then submit all recorded inspections to the Engineer. Upon review the Engineer will either instruct the Contractor to cease sewer cleaning or to continue cleaning of the sewer in question using methods detailed in these Specifications.
3. Should the Engineer or the Contractor identify such a special circumstance, the Contractor shall formally notify the Engineer in writing of the special circumstance, make any pertinent recommendations, and proceed according to the Engineer's directions.
4. If the Contractor claims all or any portion of a sewer to be inaccessible for cleaning, for any reason, the Engineer shall have the exclusive right to provide for alternative arrangements for obtaining sewer cleaning services for the portion of sewer in question. If cleaning of any portion of the declared inaccessible portion is obtained by services not provided by the Contractor, the Contractor shall be responsible for the costs of those services performed by a third party for the completion of work required in the Contract.

### 33.31.20.06 SEWER INSPECTION

#### A. General

1. As specified by the Engineer, sewer inspections are to be completed using closed-circuit television (CCTV) or via an approved alternate method.
2. Sewer inspections shall include not only sewer inspection operations but also documentation of CCTV sewer inspections.

#### B. Manholes

1. Inspection of all manholes included in the scope of work shall be performed via video documentation.
2. The inspection shall include a condition survey of all interior surfaces from the cover to the invert of the flow channel.
3. The inspection notes shall include general manhole details including:
  - a. manhole number,
  - b. manhole construction (e.g., cast-in-place concrete, precast concrete, brick, etc.),
  - c. manhole depths (from top of cover to bottom of elevation adjustment rings, and top of cover to the flow channel invert.
4. The inspection notes shall indicate the location and severity of:
  - a. infiltration,
  - b. exposed reinforcement steel,
  - c. corroded steps,
  - d. significant interior surface anomalies,
  - e. structural defects,
  - f. any other noticeable defect or issue affecting the manhole.

#### C. Ensuring Internal Pipe Visibility

1. General
  - a. Inspection of sewers using CCTV methods shall not proceed until 90% of the internal circumference of a sewer is visible above the surface of the flow.
2. Submerged Sewer Main
  - a. If there is significant infiltration within a given segment of main the Contractor shall take necessary action through a dewatering plan approved by the Engineer or perform the inspection using technology approved by the Engineer which will allow inspection within a submerged environment. There will be no additional allowance for such work.
3. Sewer Flow Control
  - a. Flow controls may be completed by either
    - i. inserting temporary sewer plugs into sewers upstream of those sewers to be inspected-only or cleaned and inspected, or
    - ii. using pumping equipment, bypassing flows around sewers.
  - b. Alternatively, if, throughout the entire length of a sewer in question, using hydraulically-powered sewer cleaning equipment, flow can be temporarily controlled to the extent required in these specifications, for the purpose of completing sewer inspection operations using CCTV methods, while flow is temporarily controlled, it will be permissible to couple sewer inspection operations with sewer cleaning operations.
4. Sewer Plugging

- a. When plugging a sewer, the plug assembly shall be designed such that all, or any, portion of the sewage, within the plugged sewer, can be released at varying rates.
  - b. When a sewer is plugged, flow shall not be discharged from the sewer collection system except to a container specifically for the purpose and intended for transport.
  - c. If approved by the Engineer, the Contractor may collect and transport flows impeded by constructed plugs to a downstream manhole where the sewage can flow unimpeded to the wastewater treatment plant (WWTP).
  - d. The Contractor shall be solely responsible for determining the capacity of equipment necessary to transport flows to the WWTP.
5. Bypass Pumping
- a. When diverting flows around sewers in which work is to be performed, the Contractor shall provide pumping equipment with sufficient capacity to bypass wet weather flows.
  - b. The Contractor shall understand that the Engineer does not have information regarding wet weather flows within specific sewers.
  - c. The Contractor will be responsible for construction, operation, and deconstruction of pumping equipment, including any measures needed to protect public health and public safety.
  - d. Engines shall be equipped to keep noise at a minimum.
  - e. When flow in a sewer is bypassed, flow shall not be discharged from the sewer collection system except for collection and transport, if necessary.
- D. Sewer Inspections Completed Using CCTV-General
- 1. The purpose of inspecting sewers using CCTV is to obtain high quality, recorded images of the entire interior condition of sewers, connecting sewers as viewable from the receiving, downstream, sewers without use of camera launching devices, and adjoining manholes.
  - 2. Recorded images may be produced by either inspection equipment that provides the field operator thereof with pan, tilt, and zoom capabilities or inspection equipment that produces inspection recordings that, when coupled with enabling software, allow off-site users the capability to pan, tilt, and zoom the entire lengths and circumferences of inspected sewers.
  - 3. Prior to the commencement of the Project, the Contractor shall provide the Engineer with the domain of feature descriptions made part of the inspection software.
    - a. The Engineer shall review the domain and, if any, provide the Contractor with modifications that are to be made to the domain to be used as part of this Project.
    - b. At minimum, domains shall include the following descriptions of features commonly witnessed in sanitary sewers: tee connection, plugged; wye connection, plugged; tap connection, plugged; tee connection; wye connection; tap connection; lamphole; manhole; and flush tank.
    - c. Additionally, the descriptions shall reference the orientation of features relative to the direction of camera travel; for example, left, right, crown and invert.
- E. Sewer Inspections Completed Using CCTV-Equipment

1. The basic functions of systems made part of the camera and transport assembly, include, but are not limited to, the following:
  - a. illumination of the interior of the sewers to be inspected,
  - b. transport of inspection camera(s) throughout the full length of the sewers to be inspected,
  - c. measurement of the relative location of the assembly,
  - d. clear, focused inspection of the whole of the sewers to be inspected,
  - e. and recording of images generated by the inspection of sewers.
2. Inspection camera(s) shall:
  - a. be capable of producing steady, clear, solid state, color video images of all aspects of the internal condition of sewers,
  - b. produce images which are not geometrically distorted,
  - c. provide field operators with pan, tilt, and zoom capabilities via remote control while moving forward, backward, or not moving,
  - d. shall have a total effective zoom ratio no less than 40:1,
  - e. produce a color image with a resolution of at least 379,392 elements (NTSC) or 720 x 576 pixels (digital),
  - f. include both an automatic white balance feature and an auto-centering feature, the latter shall be provided to allow auto-repositioning of the camera field of vision to the zero-degree X-Y axis position,
  - g. have integrated lighting which allows a clear picture of the entire circumference of sewers being inspected not only at the location of the camera(s) but also at least 20' in front of and beyond (lighting shall be sufficient to allow for the production of images that clearly show at least 10' of the interior of sewer service connections upstream of the connection to the public sewer assuming the absence of inhibitive fittings),
  - h. have an integrated transport assembly, which may be driven, floated, or winched\* through sewers to be inspected, capable of moving through sewers designated for inspection at rates that facilitate the acquisition of inspection recordings and shall,
  - i. be such that the position of the camera(s) and lighting systems is centered in the sewers being inspected,
  - j. not obstruct or interfere with inspections, and
  - k. be able to negotiate gradual bends and sweeps in sewers.
  - l. if the camera(s) does (do) not meet these Specifications, the inspection recordings shall be rejected.
  - Personnel shall not be allowed to manually transport inspection equipment through sewers. When floating a camera assembly, the rate of travel must be controlled.
3. Location measurements shall:
  - a. be provided at all times during sewer inspection operations,
  - b. include a footage counter that tracks the distances the camera and transport assemblies have traveled within sewers being inspected (note that an acceptable alternative for satisfying this requirement is the provision of distance measurements relative to inspection starting locations),
  - c. utilize a standard foot as the unit of measurement other than the standard foot will not be accepted,

- d. begin at the center of entry manholes and the corresponding counters are to begin at 0.0 feet.
- e. be represented in tenths of a foot,
- f. be accurate within, plus or minus, one foot\*\*,
- g. be visible in all recorded images (the distance of the transporter from the center of the entry manhole),

\*\* Accuracy of the distance meter shall be checked by use of a walking meter, steel tape, or other suitable device. The inspection of a sewer shall not be accepted in which the footage counter is found to be inaccurate. The following are intended to be examples, but not a complete listing, of situations that may invalidate a distance measurement:

- An inaccuracy in the footage displayed on the counter is discovered by use of a separate method to verify distances.
- The operator reverses the progress of the transport and introduces redundancy in the distance measurement by twice including the length of a section of sewer.
- The counter at the beginning of an inspection is in error.
- The starting position of the counter is other than the center of the entry manhole.
- Slack in the cable allows the transport to traverse through the line without the corresponding increase in the footage counter.

4. Sewer inspection deliverables shall:
  - a. be developed utilizing software that is capable of providing both inspection recording files and reports,
  - b. include digital video inspection files in either MP4 or AVI format (recordings provided in VHS format will not be accepted) that include images recorded throughout sewer inspections, and
  - c. include reports in Adobe PDF format (one for each sewer section inspection). Reports shall include the same information input into the log of the sewer inspection as detailed below.

#### F. Procedure

1. Sewer inspections completed using CCTV equipment shall be done one sewer at a time, from ending structure to ending structure.
2. The camera shall be moved through the sewer at a consistent, moderate speed that will allow for general viewing of the recording.
3. The preferred direction of camera travel is from the upstream structure to the downstream; travel from downstream to upstream shall only be attempted if access to the upstream structure is impossible or previous attempts from the upstream structure have been arrested prior to completion of inspection.
4. While traveling through the sewer, the camera shall at all times be oriented such that the flow is shown at the bottom of the image.
5. The Contractor must continue inspections until the camera is completely within or below adjoining structures including manholes, lamp-holes, flush tanks, etc.

6. The Contractor shall take care to both completely inspect the entire circumferences of all joints between structures and inspected sewers.
7. Each manhole shall also be inspected.
8. The camera shall be stopped to inspect all connections and defects including, but not limited to, tees, taps, wyes, risers, connecting sewers, lamp-holes, pipe disjunctions, holes, splits, leaks, etc.
  - a. The camera shall pause to inspect both upstream into connections and entire circumferences of joints between connections to sewers.
  - b. Additionally, the camera shall be stopped and the camera head swiveled to better view any actual, or suspected, pipe damage.
  - c. Once documentation of a problem is completed, the camera shall continue traveling through the sewer.
9. The Contractor shall input a description of the feature into an electronic record.
10. Meticulous logging of features encountered, coupled with input into the header of each file created, will be the basis for reports.
11. Inputted into the log of each sewer inspection shall be features encountered, their distance from the entry manhole and their orientation within the sewer.
12. If, during the CCTV inspection operation, the camera will not pass through the entire sewer, the Contractor shall set up his equipment so that the inspection can be performed from the opposite manhole, if one is available.
13. If the sewer has only one adjoining manhole and a reverse setup is not possible, the inspection of the sewer shall be considered complete.
14. If again, upon setup at the opposite manhole, the camera fails to pass through the entire sewer, the inspection shall be considered complete and no additional inspection work will be required.
15. Based upon the Contractor's footage counter, the Contractor shall report uninspected portions of sewers to the Engineer and the reason(s) that inspection was halted.
16. When performing an inspection from a reverse setup, the Contractor shall only be required to inspect that portion of the sewer that was not inspected on the previous setup.
17. If any portion of the sewer is not able to be inspected from either direction for reasons beyond the Contractor's control, the inspection of the sewer in question shall be considered incomplete.
18. If the Contractor claims all or any portion of a sewer to be inaccessible for inspection, for any reason, the Engineer shall have the exclusive right to provide for alternative arrangements for obtaining sewer inspection services for the portion of sewer in question. If inspection of any portion of the declared inaccessible portion is obtained by services not provided by the Contractor, the Contractor shall be responsible for the costs of those services performed by a third-party for the completion of work required in the Contract.

#### G. Documentation

1. General:
  - a. Proper and correct documentation of the sewer inspection is imperative.

- b. An inspection that is not properly and correctly documented, in accordance with these specifications, shall invalidate the recording of the images produced from the inspection and subject it to rejection by the Engineer.
  - c. A rejection, for any reason, of any inspection will require that the Contractor repeat the cleaning and inspection of the sewer in question.
2. Labeling:
- a. Header information shall be provided at the beginning of each inspection recording and shall include the following:
    - i. the name of the City of Box Elder which can be referred to as COBE,
    - ii. the project number,
    - iii. the Contractor's name,
    - iv. the starting time, ending time, and date of sewer inspection,
    - v. the identification of the entry and terminus manholes (the City's manhole identifications as provided by the Engineer),
    - vi. the direction of camera travel,
    - vii. the identification of the sewer being inspected,
    - viii. and characteristics of the pipe including the pipe diameter.
3. Files:
- a. For each sewer inspected and each attempt to inspect same, separate files shall be produced and provided to the Engineer.
  - b. Each file shall include the inspection recording, in whole or in part, of one and only one sewer, from the point of entry of the inspection equipment to the terminus of the sewer.
  - c. Files that contain the whole or partial inspection recordings of multiple sewers shall be rejected.
  - d. Files shall not be spliced, split, cut, or a collection of joined files.
  - e. Files shall be produced to meet the requirements of these specifications yet minimize file sizes.
  - f. Files shall be named in the following format:
    - i. 4-number designations for the year followed by 2-number month and 2-number date with nothing between them followed by
    - ii. a space and then the Project number and, finally
    - iii. another space and the identification of the sewer inspected (e.g., from manhole to manhole).
    - iv. For example, a file might be named "20190531 PWS 01-2019 A0026-A0025".
  - g. Files shall be provided to the Engineer on an external storage device or another media/method approved by the Engineer prior to the receipt of proposals.
  - h. If using an external storage device, it shall
    - i. have been purchased new by the Contractor specifically for this Project,
    - ii. be unused prior to this Project,
    - iii. become the property of the Engineer upon receipt from the Contractor,
    - iv. be formatted for use with a Windows based PC,
    - v. and verified to be virus free prior to presentation to the Engineer.
  - i. Inspection recordings shall only be considered complete once files are transferred to the Engineer, successfully accessed and reviewed for conformance with these Specifications.

- j. The Contractor is encouraged to duplicate and keep copies of all files transferred to the Engineer.
- H. Locating Manholes and Making Them Accessible
- 1. The Contractor shall coordinate with City sewer staff the location and access to all manholes which are not locatable at the time of cleaning and inspection activities.
  - 2. The Contractor shall be responsible for disposing of all excavated materials resulting from the location of manholes.

## **PRICE AND PAYMENT**

### **33.31.20.07 SEWER MAIN CLEANING AND INSPECTION**

- A. Sewer main cleaning and inspection work will be measured to the nearest linear foot and will be paid for at the contract unit price per linear foot.
- B. Payment for this item will also be full compensation for labor, equipment, tools, backfilling, furnishing, preparing, testing, and placing materials and incidentals necessary, including disposal of excavation and discarded materials. Such payment shall include cushion material.

### **33.31.20.08 SEWER MANHOLE CLEANING AND INSPECTION**

- A. Sewer manhole cleaning and inspection work will be considered incidental to the sewer main cleaning and inspection work. The flow channels through manholes are to be paid, once (i.e., should a sewer manhole have more than one inlet, channel length will be paid for only one of the inlets), based on the manhole interior diameter and the smallest pipe size associated with any of the inlets, or the closest pipe size bid schedule line item should there not be a pay item for the smallest inlet pipe size.

**END OF SECTION**



## SECTION 33.41.13 – STORM SEWER PIPING

### GENERAL

#### 33.41.13.01 SUMMARY

- A. This section includes furnishing and installing polyethylene, concrete, PVC, and metal storm sewer piping.

#### 33.41.13.02 RELATED WORK

- A. Section 03.05.13 – Concrete
- B. Section 31.23.16 – Excavation, Trenching and Backfill

#### 33.41.13.03 REFERENCES

- A. South Dakota Department of Transportation (SDDOT) Standard Specifications for Roads and Bridges, most recent edition. Applicable section(s) will include Pipe Culverts and Pipe Culverts and Drainage Tubing.
- B. AASHTO M 36 – Standard Specification for Corrugated Steel Pipe, Metallic-Coated for Sewers and Drains
- C. AASHTO M 167 – Standard Specification for Structural Plate for Pipe, Pipe-Arches, and Arches
- D. AASHTO M 170 – Standard Specification for Reinforced Concrete Culvert, Storm Drain, and Sewer Pipe
- E. AASHTO M 196 – Standard Specification for Corrugated Aluminum Pipe for Sewers and Drains
- F. AASHTO M 206 – Standard Specification for Reinforced Concrete Arch Culvert, Storm Drain, and Sewer Pipe
- G. AASHTO M 207 – Standard Specification for Reinforced Concrete Elliptical Culvert, Storm Drain, and Sewer Pipe
- H. AASHTO M 219 – Standard Specification for Corrugated Aluminum Alloy Structural Plate for Field-Bolted Pipe, Pipe-Arches, and Arches
- I. AASHTO M 252 – Standard Specification for Corrugated Polyethylene Drainage Pipe
- J. AASHTO M 294 – Standard Specification for Corrugated Polyethylene Pipe
- K. ASTM D2241 – Standard Specification for Poly Vinyl Chloride (PVC) Pressure-Rated Pipe (SDR Series)

- L. ASTM D3139 – Standard Specification for Joints for Plastic Pressure Pipes Using Flexible Elastomeric Seals
- M. ASTM F477 – Standard Specification for Elastomeric Seals (Gaskets) for Joining Plastic Pipe.

#### 33.41.13.04 SUBMITTALS

- A. Storm Sewer Pipe.
- B. Storm Sewer Pipe End Sections.
- C. Bedding Material.
- D. Schedule.

#### 33.41.13.05 ACCEPTANCE

- A. The work will not be accepted until satisfactory pipe backfilling, testing, and cleanup is complete.
- B. If the work does not meet the specified requirements of this section and related sections, remove, replace, and retest at no additional cost.

### PRODUCTS

#### 33.41.13.06 MATERIALS

- A. Reinforced Concrete Pipe (RCP)
  - 1. RCP shall conform to AASHTO M 170 and the Pipe Culverts and Drainage Tubing section of the most edition of the SDDOT Standard Specifications for Roads and Bridges.
- B. Corrugated Metal Pipe (CMP)
  - 1. CMP shall conform to AASHTO M 36 or M 196 and the Pipe Culverts and Drainage Tubing section of the most edition of the SDDOT Standard Specifications for Roads and Bridges.
- C. Corrugated Polyethylene Tubing
  - 1. Corrugated polyethylene tubing shall conform to AASHTO M 252 and the Pipe Culverts and Drainage Tubing section of the most edition of the SDDOT Standard Specifications for Roads and Bridges.
- D. High Density Polyethylene (HDPE) Pipe
  - 1. Corrugated polyethylene tubing shall conform to AASHTO M 294 and the Pipe Culverts and Drainage Tubing section of the most edition of the SDDOT Standard Specifications for Roads and Bridges.
- E. Poly Vinyl Chloride (PVC) Pipe
  - 1. PVC Pipe shall conform to ASTM D2241 – Standard Specification for Poly Vinyl Chloride (PVC) Pressure-Rated Pipe (SDR Series)

**F. Polypropylene (PP)**

1. Polypropylene shall have a smooth interior and annular exterior corrugations and shall be joined using a bell and spigot joint meeting the requirements of ASTM F2881. The joint shall be watertight according to the requirements of ASTM D3212. The spigot shall utilize two gaskets meeting the requirements of ASTM F477. Gaskets shall be installed by the pipe manufacturer and covered with a removable, protective wrap to ensure the gaskets are free from debris.

**EXECUTION**

**33.41.13.07 CONSTRUCTION REQUIREMENTS**

- A. Storm sewer piping shall conform to the most recent edition of the SDDOT Standard Specifications for Roads and Bridges.

**33.41.13.08 UTILITY CONFLICTS**

- A. Refer to Section 31.23.16.

**33.41.13.09 INSPECTION**

**A. General**

1. Verify that dimensions and elevations are as indicated on the plans.
2. Verify that all products are in new condition.
3. Inspect pipe and fittings for defects.
4. Remove materials from the site that are defective, damaged, used, unsound, or that otherwise do not meet the specifications.
5. The Contractor shall be responsible for all related inspection and repair costs, including any necessary concrete or asphalt removal and/or resurfacing.

**B. Video Inspection**

1. A video inspection shall be performed on all new storm sewer piping.
2. The video inspection shall consist of viewing the inside of all new piping installed to determine proper alignment, joining, infiltration, etc.
3. The Contractor shall correct, at his own expense, any defects, including areas of infiltration, discovered during the video inspection.
4. The expense of the video inspection shall be borne entirely by the Contractor.
5. If defective workmanship of material or construction is noted, the Contractor at no expense to the City, shall correct the deficiency and provide another video inspection to verify the work was satisfactorily corrected.

**C. Leakage Test**

1. Unless otherwise noted, or requested by the Engineer, there shall be no leakage test of new storm sewer piping.
2. If a leakage test is necessary:
  - a. The Contractor shall furnish all necessary equipment and be responsible for conducting the leakage test in the presence of the Engineer or designee.
  - b. The requirements shall be as outlined in section 33.31.13 for leakage testing of sanitary sewer main except:

- i. Pipeline segments between drop inlets or storm sewer manholes shall be tested separately.
- ii. Mechanical or pneumatic plugs shall be placed in the line at opposing drop inlets or storm sewer manholes and each plug braced as a safety precaution.

## PRICE AND PAYMENT

### 33.41.13.10 METHOD OF MEASUREMENT

#### A. Pipe Culverts

1. Furnishing and installing pipe culverts will be measured by the foot over the centerline of the pipe for the respective types, classes, and sizes.
2. The length will be obtained by multiplying the nominal length of the sections by the number of sections used.
3. When an installation requires that a section of pipe be cut, such as storm sewer installations, the length will be the actual length required, rounded up to the nearest even 2 feet.

#### B. End Sections

1. Furnishing and installing end sections for the respective type and sizes of pipe culverts will be measured by the number of complete end sections furnished and installed.

### 33.41.13.11 BASIS OF PAYMENT

#### A. General

1. Basis of payment shall include all storm sewer piping, fittings, special sections, gaskets, drainage fabric, construction adhesive, preformed mastic, connecting devices, coupling bands, bedding and backfill material and placement, site restoration (including replacing disturbed surfacing material), and all other appurtenances required to complete the work as specified.
2. Payment shall include all labor, equipment, and incidentals required to complete the work.

#### B. Pipe Culverts

1. Furnishing and installing pipe culverts will be paid for at the contract unit price per foot for the types, classes, and sizes furnished and accepted.
2. The Contractor may substitute a higher class of pipe than specified at their own expense.

#### C. End Sections

1. Furnishing and installing end sections will be paid for at the contract unit price per each for the type and size furnished and accepted.

## END OF SECTION

## **SECTION 33.44.13 – STORM SEWER INLETS**

### **GENERAL**

#### **33.44.13.01 SUMMARY**

- A. This work consists of furnishing materials and the construction of drop inlets.

#### **33.44.13.02 RELATED WORK**

- A. Section 03.05.13 – Concrete
- B. Section 31.23.16 – Excavation, Trenching and Backfill

#### **33.44.13.03 REFERENCES**

- A. AASHTO M 85 – Standard Specification for Portland Cement.
- B. AASHTO M 105 – Standard Specification for Gray Iron Castings.
- C. South Dakota Department of Transportation (SDDOT) Standard Specifications for Roads and Bridges, most recent edition. Applicable section(s) will include Pipe Culverts and Drop Inlets.

#### **33.44.13.04 SUBMITTALS**

- A. Inlet precast details (shop drawings).
- B. Castings.
- C. Mortar mix design.
- D. Inlet and drain piping installation plan.

### **PRODUCTS**

#### **33.44.13.05 INLETS**

- A. Unless otherwise noted, inlets shall be precast.
- B. Precast inlets will require details (shop drawings) and reinforcement inspections be submitted to and approved by the Engineer prior to ordering.
- C. Unless otherwise noted, cast-in-place inlets shall be constructed in accordance with the Drawings.
- D. All inlet/outlet piping penetration(s) through drop inlets shall be fabricated to accommodate any inlet/outlet piping installation angle noted on the plans.

#### 33.44.13.06 CONCRETE

- A. Portland cement concrete material shall meet the requirements of the Drop Inlets section of the most recent edition of the SDDOT Standard Specifications for Roads and Bridges as well as section 03.05.13.

#### 33.44.13.07 CASTINGS

- A. Frames and gratings shall consist of approved gray iron castings meeting the requirements of AASHTO M105, Class 30, for material and to the detailed plan drawings for dimensions and weights.
- B. Gratings shall fit the frames with which they are to be used.
- C. Inaccuracies of bearing shall be corrected by machining or grinding before use or replaced with new assemblies.

#### 33.44.13.08 STEEL REINFORCEMENT

- A. Steel reinforcement shall meet the requirements of Section 03.05.13. All reinforcing steel used in the construction of drop inlets shall be epoxy coated.

#### 33.44.13.09 MORTAR

- A. Mortar shall consist of one (1) part Portland Cement and two (2) parts mortar sand. Portland Cement shall conform to the requirements of AASHTO M 85, Type II or Type V. Mortar mix, including materials, shall be approved by the Engineer.

#### 33.44.13.10 CURING COMPOUND

- A. Any curing compound used shall conform to the requirements of AASHTO M148, Type 2.

#### 33.44.13.11 INLET AND OUTLET PIPING

- A. Inlet and outlet piping material shall meet the requirements of the Pipe Culverts and Drop Inlets sections of the most recent edition of the SDDOT Standard Specifications for Roads and Bridges.
- B. Inlet and outlet pipe connections shall be of the same size and kind and shall meet the same requirements as the pipe to which they connect.
- C. Unless otherwise permitted by the Engineer, pipe sections shall be flush on the inside of the structure wall and project outside sufficiently for proper connection with the next pipe section.
- D. Masonry shall fit neatly and tightly around the pipe.
- E. Inlet and outlet piping shall be tested in accordance with the provisions contained in section 33.41.13.

## EXECUTION

### 33.44.13.12 INSTALLATION

#### A. General

1. Install inlets of the type, at the locations and elevations shown on the plans.
2. Refer to Section 31.23.16 for excavation and backfill requirements.
3. The finished surface of the concrete shall present a neat and smooth appearance.
4. Install inlets so that the walls are vertically plumb.
5. Backfill shall be placed in layers not exceeding 6 inches thick and compacted to the same degree as specified for the adjacent embankment.
6. Installations shall be finished and left in a neat appearing condition satisfactory to the Engineer.

#### B. Cast-in-Place Installation

1. Normally, drop inlet installations are expected to utilize precast concrete boxes. Curb inlets are generally cast in place, but precast curb inlets will be considered. Cast-in place inlets shall require:
  - a. Engineered cast-in-place plans and specifications (sealed by a professional engineer) are submitted to and approved by the Engineer.
  - b. Concrete shall be protected and cured in accordance with Section 03.05.13, except the minimum curing time before removing forms may be reduced to seventy-two (72) hours. The other provisions regarding curing time shall be maintained.
  - c. Upon completion and curing of the unit, the sheeting, bracing, forms, and falsework shall be removed, and the excavation backfilled.
  - d. The unit shall not be backfilled until the completion of the 72-hour curing period, or until the concrete reaches a minimum compressive strength of 3000 psi.

#### C. Bases

1. When the foundation for an inlet is in new embankment, the embankment shall be constructed to an elevation at least 1 foot above the footing before the foundation for the drop inlet is prepared.
2. The foundation shall be compacted to the satisfaction of the Engineer.
3. The foundation excavated for inlets shall be thoroughly moistened immediately prior to the placing of any cast-in-place concrete.
4. Bed precast inlet bases in a minimum of 6 inches of compacted clean sand or crushed rock.

#### D. Inlet and Outlet Piping

1. Install inlet and outlet piping according to pipe and inlet manufacturer's recommendations.
2. Inlet and outlet piping shall be installed at the locations and grade indicated on the plans.

#### E. Joint Sealants

1. Install flexible joint gaskets around entire circumference of each inlet joint.

2. Grout interior joints, including piping penetrations, with non-shrink hydraulic cement mortar or plastic cement putty.
3. Ensure that a watertight seal is provided at the joint.
4. Install exterior pipe joint collars on all inlet pipe penetrations, in accordance with manufacturer's recommendations.

F. Frames and Gratings

1. Castings shall be set in full mortar beds or secured as shown on the plans.
2. Castings shall be set accurately to the correct elevation so subsequent adjustment will not be necessary.
3. If a road finish grade exists, match inlet frames/covers to road finish grade.
4. Set inlet frames and covers to the elevation indicated on the plans.

**PRICE AND PAYMENT**

33.44.13.13 METHOD OF MEASUREMENT

- A. As provided in the contract, inlets will be measured on a per each basis.

33.44.13.14 BASIS FOR PAYMENT

- A. Payment for inlets shall be full compensation for furnishing cast-iron frames and gratings, concrete, reinforcing steel, labor, equipment, and incidentals necessary.

**END OF SECTION**



## SECTION 33.49.13 – SANITARY SEWER MANHOLES

### GENERAL

#### 33.49.13.01 SUMMARY

- A. Work covered by this section includes standard and shallow concrete manholes, standard manholes, drop manholes, adjustment rings, frames and covers for community wastewater collection systems.

#### 33.49.13.02 RELATED WORK

- A. Section 03.05.13 – Concrete
- B. Section 31.14.13 – Earthwork
- C. Section 31.23.16 – Excavation, Trenching and Backfill
- D. Section 33.31.13 – Sanitary Sewer Mains

#### 33.49.13.03 REFERENCES

- A. ASTM A48 – Standard Specification for Gray Iron Castings
- B. ASTM C443 – Standard Specification for Joints for Concrete Pipe and Manholes, Using Rubber Gaskets
- C. ASTM C478 – Standard Specification for Precast Reinforced Concrete Manhole Sections
- D. ASTM C923 – Standard Specification for Resilient Connectors Between Reinforced Concrete Manhole Structures, Pipes, and Laterals
- E. ASTM C990 – Standard Specification for Joints for Concrete Pipe, Manholes, and Precast Box Sections Using Preformed Flexible Joint Sealants
- F. ASTM C1244 – Standard Test Method for Concrete Sewer Manholes by the Negative Air Pressure (Vacuum) Test

#### 33.49.13.04 SUBMITTALS

- A. Manhole frame and cover
- B. Manhole steps
- C. Precast manhole sections
- D. Precast manhole base section
- E. Joint sealing material

F. Pipe to manhole connections

33.49.13.05 DEFINITIONS

- A. Shallow Manhole: Manholes with a depth from rim to outlet pipe invert equal to 7 feet or less, and with a flat top.
- B. Standard Manhole: Manholes with a depth from rim to outlet pipe invert greater than 7 feet but less than 8 feet, and with a conical top section.

**PRODUCTS**

33.49.13.06 MANHOLES

- A. Design and fabricate reinforced concrete manholes to conform to ASTM C478.
- B. Base Section:
  - 1. Precast integral concrete bottom section and base.
  - 2. Precast bases with channels are acceptable with written approval by the Project Engineer.
  - 3. Channel (or invert) shape:
    - a. Smooth.
    - b. Semicircular.
    - c. Same diameter as adjoining sewer pipe.
    - d. Ogee shaped, so there is no free drop.
  - 4. Drop:
    - a. Minimum: 0.10 feet through manholes measured from any invert in to the invert out.
    - b. Maximum: 2 feet through manholes measured from any invert in to the invert out.
- B. Barrel Sections:
  - 1. 48-inch inside diameter, unless otherwise specified.
- C. Cone Sections:
  - 1. Eccentric cone sections.
- D. Top Slab Sections:
  - 1. Provide manhole opening eccentrically located to allow positioning over the outlet.
- ~~E. Manhole Steps:
  - 1. Conform to ASTM A48.
  - 2. Cast and anchor steps in concrete sections, aligned to form a continuous ladder.
  - 3. Install steps so they are horizontal, protruding 5 inches, minimum.
  - 4. Material: 1/2-inch steel steps encased in neoprene or polypropylene.
  - 5. Width: 12 inches, minimum.
  - 6. Space rungs 16 inches apart.
  - 7. Maximum spacing from the top of the cone to the first rung shall be 6 inches.
  - 8. Center steps over the manhole outlet.~~
- F. Manhole Adjustment Rings:

1. Concrete rings.

G. Sewer Pipe Connection:

1. Watertight gasket precast into the manhole wall conforming to ASTM C923.
2. PSX Positive Seal Gasket System, or approved equal.

H. Joints:

1. Conform to ASTM C443.
2. Flexible gasket equal to Ram-Nek (Henry Group, Houston, Texas).
- ~~3. Plastic cement putty.~~
4. Non-shrink hydraulic cement mortar.
5. Exterior joint collar equal to Cretex Exterior Joint Sealer.

### 33.49.13.07 FRAMES AND COVERS

A. Fabricated from cast iron.

1. Clean and smooth.
2. Free from distortion, shrinkage or other defects.

~~B. Combined Weight: 325 pounds, minimum.~~

C. Conform to detail drawings.

D. Frame:

1. Designed for use with covers without open pickholes.
2. Machined, horizontal bearing surfaces.
3. Minimum casting height of (4) inches.

E. Cover:

1. Machined horizontal bearing surfaces.
2. Neoprene ring gasket.
3. Solid cover with concealed pickhole.
4. Cast with lettering "SEWER".

F. Equal to Neenah 1733-1 or Deeter 1259.

## EXECUTION

### 33.49.13.08 INSTALLATION

A. General:

1. Construct manholes at the locations and elevations shown on the plans.
2. The Contractor shall organize all manhole barrel and cone sections (e.g., numbering them following inspection) to ensure that each furnished manhole component is correct for that location and that the finished manhole will be to the grade specified.
3. Refer to Section 31.23.16 for excavation and backfill requirements.
4. Install manholes so that the walls are vertically plumb.
5. Bed precast manhole bases in a minimum of 6 inches of compacted clean sand or crushed rock.
6. Manhole Depth:

- a. Manholes 5.5 foot and greater in depth, measured from invert to rim, shall have eccentric cone top sections.
- b. Manholes less than 5.5 foot in depth shall have flat concrete covers designed for AASHTO H-20 wheel loading.

**B. Construction of Invert:**

1. PVC or PP Pipe Invert Channel:

- a. These shall be allowed in manholes where there is only one inlet and the flow channel is straight through the manhole.
- b. Install a full length of pipe through the manhole.
- c. Form a concrete bench up to the spring-line of the pipe.
- d. Slope the concrete bench toward the channel at a 1-inch per foot, minimum.
- e. Cut the top hemisphere of the pipe off for the entire length of the pipe through the manhole.

2. Formed Concrete Channel:

- a. Ensure that the channel is smooth and free of rough patches.
- b. Changes in Pipe Size or Grade: Make changes in size and grade of channels gradually and evenly.
- c. Changes in Direction: Smooth curve of as large a radius as the size of the manhole will permit with the intersection of the lines occurring at the center of the manhole. In no case shall the invert width through the manhole be greater than that of the outlet pipe.
- d. Benches: Construct the manhole floor, outside of the channel, smooth and slope toward the channel not less than 1 inch per foot but not more than 2 inches per foot.

**C. Inverts for Existing Manholes:**

1. All sewer flows shall be removed by bypass pumping or other approved methods from the manhole to be reconstructed.
2. The existing invert and bench shall be demolished to the extent necessary to maintain a minimum new concrete invert thickness of 3 inches and side thickness of 8 inches throughout the manhole.
3. Acceptable methods for demolishing the existing invert include the use of concrete saws, jackhammers, chisels and other hand tools.
4. The existing concrete shall be rough and have an approved bonding agent applied to it prior to placing the new concrete.
5. The new invert shall be constructed using a concrete mix as specified with the exception that the concrete shall be low slump.
6. Sewer flows will not be permitted on the concrete until 4 hours after the initial set has occurred and the Engineer has inspected and approved the reconstructed invert.
7. Shelves/Benches shall be formed from the top of the channel to the manhole wall and shall slope up from the channel at a minimum rate of 1 inch per foot and a maximum rate of 2 inches per foot.

**D. Connection of Sewer Main Pipe to New Manholes:**

1. Manhole connections to the sewer main shall be accomplished with a rubber boot or a gasket seal that insures a watertight seal.
2. Install sanitary sewer main according to pipe and manhole gasket manufacturers' recommendations.

3. Ends of pipes, which enter manholes, shall be cut smooth, straight; and at right angles to the pipe axis.
  4. The annular space between the boot or gasket and the pipe shall be grouted flush with the inside of the manhole such that a smooth, continuous channel is formed through the manhole.
  5. The annular space above the flow channel on top of the pipe shall not be grouted.
- E. Connection of Sewer Main Pipe to Existing Manholes:
1. Manhole connections shall be made by coring the existing manhole and installing a boot-type flexible connector consisting of a rubber gasket or boot, metal expansion ring and a metal take-up clamp, as manufactured by Press Seal Gasket Corporation, or equal. Rubber boots and gasket material shall meet or exceed ASTM C-923.
  2. Unless pre-approved by the Engineer, new pipe connections to existing brick manholes shall not be allowed. Brick manholes shall be replaced.
  3. With Engineer's approval the Contractor may cut the necessary openings into the existing manhole and make the connection thereto in a neat and workmanlike manner.
  4. The connections shall be made to make the joints around the entering sewers watertight and an approved smooth channeled flow line shall be constructed as specified for inverts.
  5. The Contractor shall create a hole in the manhole wall using a chisel hammer or other approved method.
  6. The hole shall have a maximum dimension of 6 inches plus the O.D. of the pipe and a minimum dimension of 3 inches plus the O.D. of the pipe.
  7. Concrete saws are discouraged for cutting the hole as they leave cuts in the existing manhole wall and are difficult to grout shut.
  8. If a concrete saw is used, it shall be used in a manner such that there are no saw cuts left in the existing concrete.
  9. The pipe shall be grouted into the manhole wall with non-shrink grout and a water stop gasket.
  10. The grout shall extend outside the manhole wall such that it provides a 6-inch overlap around the full circumference of the hole.
  11. The Contractor shall place a water stop on the concrete manhole barrel around (full circumference) the breakout, and grout it into place.
  12. The water stop shall be ~~American Colloid~~ "Waterstop – RX", 1 in. x ¾ in. size or equal.
  13. The grout shall also extend out/away from the manhole (around the pipe) for a length equal to the diameter of the pipe.
  14. After completing the connection to the manhole, the Contractor shall test the existing manhole for water tightness.
  15. If the manhole does not pass the test it shall be the contractor's responsibility to correct the deficiencies and demonstrate a passing test.
  16. The Contractor is responsible for correcting deficiencies in the manhole even if said deficiencies preexisted or resulted from activities not directly related to the connection tie-in.

**F. Outside Drop Construction:**

1. Install an outside manhole drop where the invert of the inlet pipe is more than 24 inches higher than the invert of the outlet pipe.
2. Use the same material as was used for the sewer main pipe to construct the drop.

3. Drop shall have the lower connection and 45-degree fitting, outside the manhole, ~~totally encased in concrete~~ completely bedded in sand or crushed gravel.
4. The interior pipe connections shall have the annular space grouted as described above.
5. Construct according to the detail drawings.

**G. Manhole Steps:**

1. When specified/required, steps shall be inserted at least 1 inch into the manhole wall and shall be aligned straight and plumb over the outlet pipe in the manhole.
2. Steps shall not be installed in manholes unless indicated on the drawings or in the specifications and approved by the Engineer.

**H. Top Slab Section Installation:**

1. Install with the opening over the outlet of the manhole.
2. Use on shallow manholes only.

**I. Conical Section Installation:**

1. Install with the opening over the outlet of the manhole.
2. Install 4 feet of manhole section with cylindrical configuration before installing a conical section.
3. Use on standard manholes.

**J. Joint Sealants:**

1. Install flexible joint gaskets around entire circumference of each manhole joint.
2. ~~Grout interior joints with non-shrink hydraulic cement mortar or plastic cement putty.~~
3. Ensure that a watertight seal is provided at the joint.
4. Install exterior joint ~~collars~~ (wrap) on all manhole joints, in accordance with manufacturer's recommendations.

**K. Adjustment Rings:**

1. Group adjustment rings in place when the manhole is constructed.
2. Install at least one adjustment ring, and no more than 12-inches of adjustment rings.
3. Discard all cracked adjustment rings.
4. Install adjustment rings with butyl rubber sealant between mating surfaces.
5. ~~Grout manhole rings on outside and inside.~~
6. Install flexible joint wrap around the entire circumference of each adjustment ring.

**L. Frame and Cover:**

1. Grade and slope:
  - a. If a road finished grade exists, set manhole frames, and covers to match the finished grade of the road.
  - b. When placed in asphalt, concrete, or gravel surfaces, frames and covers shall match both the crown slope and profile slope of the street.
  - c. The cover shall be set at an elevation and slope that is not above the pavement surface and no more than 1/4 inch below the pavement surface at all points around the circumference of the cover.
  - d. Decreasing the surfacing thickness around the manhole frame and cover, as a method of achieving the above tolerances, is not permitted.
  - e. Frames and covers placed in turfed areas shall be set 1 inch above the finished grade.

- f. Frames shall be ~~blocked and shimmed~~ (grouted) to correct elevations and slopes prior to placing pavement.
  - g. The lid shall be adjusted to match both the cross slope of the street and the profile of the street.
  - h. Butyl rubber shall be installed between the frame and adjusting ring, additionally an exterior joint wrap shall be installed.
  - i. Following paving, the frame shall be checked for correct placement and adjusted as necessary.
  - ~~j. The joint between frame and adjusting ring shall then be grouted watertight with non-shrink grout.~~
  - ~~k. Blocks and shims shall be placed no closer than 2 inches from the inside edge of the adjusting ring.~~
  - ~~l. The internal frame seal shall be installed after the manhole frame and cover has been installed in its final position and is complete.~~
  - m. If a finished grade does not exist, set manhole frames and covers to the elevation indicated on the plans.
  - n. Refer to Section 31.14.13 for finish grading requirements.
2. Vertical Adjustment of Manhole Frames and Covers:
- a. Adjusting rings shall be installed per the Standard Details and as specified herein, adjustments greater than those shown on the details shall be accomplished by replacing or adding additional barrel sections rather than adjusting rings.
  - b. Plastic or rubber adjusting rings may be used in lieu of concrete adjusting rings with prior approval of the City Engineer.
  - c. The plastic or rubber adjusting rings shall be installed as recommended by the manufacturer.
  - d. No shims or other leveling devices, other than leveling rings provided by the manufacturer, will be permitted with use of the plastic or rubber adjusting rings.
  - e. The annular space between the adjusting rings shall be sealed using an approved butyl rubber sealant, water stop material will not be permitted as it does not fully fill the space and further settlement of the frame occurs after installation.
  - f. The first plastic adjusting ring on existing manholes may require leveling with concrete mortar and therefore the first plastic ring may be set in mortar.
  - g. The manhole frame and adjusting rings where concrete adjusting rings are used shall be set in a full bed of mortar to the grade and slope as specified.
  - h. The mortar shall be tuck pointed between rings and shall not be applied to the inside diameter surface of the adjusting rings.
  - i. Smearing mortar on the inside of the adjusting rings will cause for rejection of the work. When adjusting rings vary in thickness (2 in. & 4 in.) the largest ring (4 in.) shall be placed on top, directly under the frame.
  - j. New Manholes:
    - i. New Manhole barrels and cone sections shall be manufactured to a tolerance that provides from 2 to 8 inches of vertical adjustment between the top of the cone and the bottom of the frame. Vertical adjustments, between the top of the cone and the bottom of the frame, greater than 8 inches shall be accomplished by installing a new appropriately sized manhole barrel section.
    - ii. Rings shall be vertically aligned to be straight with the top of the cone section without any offset.
  - k. Existing Manholes:

- i. Existing manhole frames and lids may be adjusted to grade by adding additional adjusting rings.
- ii. The vertical adjustment between the top of the cone and the bottom of the frame, however, shall not exceed 18 (12) inches.
- iii. Vertical adjustments, greater than 18 (12) inches shall be accomplished by installing a new appropriately sized manhole barrel section.
- iv. Rings shall be vertically aligned to be straight with the top of the cone section and with each other without any offset.
- v. Steel adjusting rings that are inserted into the existing frame and allow the cover to be raised are not permitted must be approved by the City Engineer.
- vi. All manhole adjustments shall be done as specified above.

**M. Chimney Seal:**

1. Unless pre-approved by the Engineer, manhole chimney seals shall NOT be installed. Whether an existing manhole is adjusted or a new manhole is installed, the manhole chimney shall be sealed. All manhole chimneys shall be sealed using a manhole internal frame seal.
2. The seal shall be installed according to the manufacturer's recommendations and when properly installed will prevent the inflow of water between the manhole cone and the frame and cover.

**N. Coating for Concrete Manholes and Lift Stations Wet Wells:**

1. When indicated on the drawings or specifications a corrosion resistant interior grout liner shall be provided on manholes or lift station wet wells.
2. The liner may be field applied or applied at the manufacture's site. The liner shall be "Earthcoat 400P Pipe Coating" as manufactured by Earthcoat International, Appleton, WI, or equal.
3. The liner shall be specifically formulated for coating the interior of concrete manholes or wet wells for corrosion protection. The material shall be applied as per manufacturer's recommendations. Manhole coating color shall be as approved by the Engineer.

**33.49.13.09 ABANDONMENT**

**A. Manhole Abandonment:**

1. Existing Manholes to be abandoned shall have all pipes plugged with concrete extending into the abandoned pipe one foot or one pipe diameter, whichever is greater.
2. The upper 4 ft. of the manhole shall be broken or removed and the manhole filled with compacted select granular backfill material, as approved by the Engineer.
3. The Contractor shall not backfill manholes to be abandoned until the Engineer/Inspector has inspected each plug.
4. Unless shown otherwise indicated, the Contractor shall salvage manhole frames and covers and deliver to and unload them at the City Shop on Cimarron Drive.

**B. Sewer Main Abandonment:**

1. Refer to Section 33.31.13.

**33.49.13.10 INSPECTION**



A. Visual Test:

1. The Engineer/Inspector will visually inspect each manhole exterior and interior for flaws, cracks, holes, or other deficiencies, which may affect the operation or watertight integrity of the manhole.
2. Should any deficiencies be discovered, the Contractor shall correct them to the satisfaction of the Engineer and at no cost to the Owner.
3. Manhole barrels and cones that have cracks or holes that extend from the interior of the barrel or cone to the exterior shall be replaced.
4. Manhole barrels or cones that have spalls or cracks that extend to or through the O-ring gasketed joint shall be replaced.
5. For other deficiencies or flaws the Contractor may submit to the Engineer a written repair procedure for consideration.
6. The Engineer may or may not permit the proposed repair method and by allowing a repair method does not, in any way, remove or alleviate any testing requirements.

### 33.49.13.11 TESTING

B. General:

1. Manhole tests shall be performed on all newly installed manholes and on existing manholes where new sewer main connections have been made.
2. The preferred manhole leakage test method is the vacuum test rather than the ex-filtration test.

C. Vacuum Test:

1. The vacuum test shall include testing the top of the manhole, excluding the adjusting rings and manhole frame and cover.
2. Testing will be allowed after backfilling has occurred.
3. The manhole vacuum tester assembly and vacuum pumps shall be as manufactured by Cherne Industries, Inc. or approved equal.
4. Repair of leaks may require the removal and replacement of manhole sections.
5. The use of grout to repair leaks is not allowed.
6. Preparation:
  - a. Plug all lift holes.
  - b. Temporarily plug all pipes entering the manholes.
  - c. Brace all plugs to prevent them from being drawn into the manhole.
  - d. Install 2 accurate vacuum pressure test gauges to monitor the test.
    - i. Vacuum pressure gauges shall have graduation marks, at minimum, for every 0.2 in. of mercury and be capable of interpreting pressure readings within 0.1 in. of mercury.
    - ii. The pressure reading deviation between the two pressure gauges shall not be greater than 0.1 in. of mercury.
7. Procedure (according to ASTM C1244):
  - a. Place test head at the top of the manhole in accordance with manufacturer's recommendations.
  - b. Vacuum manhole to ~~-4.9 psi~~ (10 inches of mercury) vacuum.
  - c. Determine elapsed time for the pressure to drop ~~0.5 psi~~ (1 inch of mercury) from the test pressure and use the following table to determine acceptability.
  - d. The manhole shall pass if the time for the vacuum reading to drop from 10 in. of mercury to 9 in. of mercury meets or exceeds the values indicated in the table below.

**Minimum Test Times for Various Manhole Diameters (ASTM C1244)**

<i>Diameter, in</i>		30	33	36	42	<b>48</b>	54	60	66	72
Depth (ft)	<i>Times, s</i>									
	8	11	12	14	17	<b>20</b>	23	26	29	33
10	14	15	18	21	<b>25</b>	29	33	36	41	41
12	17	18	21	25	<b>30</b>	35	39	43	49	49
14	20	21	25	30	<b>35</b>	41	46	51	57	57
16	22	24	29	34	<b>40</b>	46	52	58	67	67
18	25	27	32	38	<b>45</b>	52	59	65	73	73
20	28	30	35	42	<b>50</b>	53	65	72	81	81
22	31	33	39	46	<b>55</b>	64	72	79	89	89
24	33	36	42	51	<b>59</b>	64	78	87	97	97
26	36	39	46	55	<b>64</b>	75	85	94	105	105
28	39	42	49	59	<b>69</b>	81	91	101	113	113
30	42	45	53	63	<b>74</b>	87	98	108	121	121

- e. If the pressure drop time is less than that in the table for the diameter of manhole being tested, the test shall be considered failed.
- f. If the manhole fails the initial test, necessary repairs shall be made by an approved method.
- g. The manhole shall then be retested until a satisfactory test is obtained. ~~This does not mean that the vacuum test has to be repeated but rather a passing test has to be achieved by either the vacuum test or the ex-filtration test.~~

**D. Ex-filtration Test:**

1. The Contractor shall furnish all necessary equipment and materials and shall be responsible for conducting, in the presence of the Engineer/Inspector, an ex-filtration test on each manhole.
2. A separate manhole ex-filtration test will not be required when the manhole is tested simultaneously with the sewer pipe during an ex-filtration test.
3. It is not recommended to conduct the pipe leakage test concurrently with the manhole ex-filtration test, as the allowable parameters for head (H) in the two tests differ. However, a separate manhole ex-filtration test will not be required when manholes are tested simultaneously with the sewer pipe exfiltration test.
4. If the Contractor wishes to concurrently test the pipe and manhole then the table below may be used to assist in measuring the pipe loss for a concurrent test.
5. The manhole shall not allow ex-filtration of water of more than 0.10 gallons per hour per foot diameter per foot head (0.10 gal/hr/ft dia/ft head) with head being measured from the top of the water surface in the test manhole to groundwater level outside the manhole or to the bottom of the manhole, whichever is less.
6. Preparation:
  - a. All pipes leading into or out of the manhole shall be plugged to provide a watertight seal and the manhole filled with water to a level three (3) to four (4) inches below the casting rim or lid.
  - b. The water shall be allowed to stand for two (2) hours prior to beginning the test to allow for absorption into the manhole.

- c. If the water has dropped at the end of the two (2) hour stabilization period, additional water shall be added to bring the water level to at least three (3) to four (4) inches below the casting rim or lid, as initially was done.
  - d. If the head is greater than 30 feet refer to the plan drawings for ex-filtration testing requirements.
7. Procedure:
- a. The minimum test period shall be for two (2) hours and the values derived from the table below will need to be adjusted for the actual test time.
  - b. Following the test period measure the makeup water required to bring the water level back to the original level.
  - c. If the amount of makeup water is less than that shown in the table below the manhole passes.
  - d. If the manhole fails to meet these requirements, the Contractor shall, at his own expense, determine the source of leakage, repair or replace all deficiencies, and retest the installation until passing, all in a manner approved by the Engineer.
  - e. This does not mean that the Ex-filtration test has to be repeated, but rather a passing test has to be achieved by either the ex-filtration test or the vacuum test.
  - f. The Contractor shall anticipate the need to conduct multiple tests in order to meet the above requirements and shall conduct testing in such a manner and sequence that the requirements indicated above are achieved.
  - g. Water used for ex-filtration testing shall be clean, potable water and shall not be discharged into the sewer system.
  - h. Upon completion of the test, if the Contractor desires to discharge the water to the sewer system and the Engineer has no objection, the Contractor shall contact the wastewater treatment plant manager and request permission for same. If such permission is granted the discharge shall be allowed.

**MANHOLE EX-FILTRATION TEST - ALLOWABLE LEAKAGE**

**Head Allowable water drop in casting and cone per hour**

	<b>4 Foot Diam.</b>		<b>5 Foot Diam.</b>		<b>6 Foot Diam.</b>	
<b>(Feet)</b>	<b>(gals) (Inches)</b>		<b>(gals) (Inches)</b>		<b>(gals) (Inches)</b>	
2 0.	8	0.32	1.0	0.40	1.2	0.48
4	1.6	0.64	2.0	0.80	2.4	0.96
6	2.4	0.96	3.0	1.21	3.6	1.45
8	3.2	1.29	4.0	1.61	4.8	1.93
10	4.0	1.61	5.0	2.01	6.0	2.42
12	4.8	1.93	6.0	2.42	7.2	2.90
14	5.6	2.25	7.0	2.82	8.4	3.38
16	6.4	2.58	8.0	3.22	9.6	3.87
18	7.2	2.90	9.0	3.63	10.8	4.35
20	8.0	3.22	10.0	4.03	12.0	4.84
22	8.8	3.55	11.0	4.43	13.2	5.32
24	9.6	3.87	12.0	4.84	14.4	5.81
26	10.4	4.19	13.0	5.24	15.6	6.29
28	11.2	4.51	14.0	5.64	16.8	6.77
30	12.0	4.84	15.0	6.05	18.0	7.26

>30 as per plans

- E. Repair all leakage or seepage that appears during the warranty period.

## **PRICE AND PAYMENT**

### **33.49.13.12 STANDARD MANHOLES**

- A. Measurement: By each installed.
- B. Basis of Payment: For manholes more than 7 feet in depth and less than 8 feet in depth, measured from the outlet invert to the top of the cover. Includes base, manhole sections, frame, cover, channel forming, bedding, and all other appurtenances required to complete the work as specified.

### **33.49.13.13 ADDITIONAL FEET OF MANHOLE**

- A. Measurement: By the additional vertical foot of depth installed beyond 8 feet of depth, as measured from the invert of the sewer main to the manhole inlet invert.
- B. Basis of Payment: Includes manhole sections and all other appurtenances required to complete the work as specified.

### **33.49.13.14 SHALLOW MANHOLES**

- A. Measurement: By each installed.
- B. Basis of Payment: For manholes less than 7 feet in depth, measured from the outlet invert to the top of the cover. Includes base, manhole sections, frame, cover, channel forming, bedding, and all other appurtenances required to complete the work as specified.

### **33.49.13.15 DROP MANHOLES**

- A. Measurement: Measurement: By vertical foot of drop as measured from the invert of the sewer main to the manhole inlet invert.
- B. Basis of Payment: Includes pipe, fittings, encasement outside the manhole, and all other appurtenances required to complete the work as specified.

### **33.49.13.16 CONNECTION TO EXISTING MANHOLES**

- A. Measurement: By each connection.
- B. Basis of Payment: Includes connection to existing manhole, reforming of sewer invert, and all other appurtenances required to complete the work as specified.

**END OF SECTION**

STANDARD DETAIL M01 – TRENCH -TYPICAL AND ALTERNATE

DETAIL W01-GATE VALVE & BOX

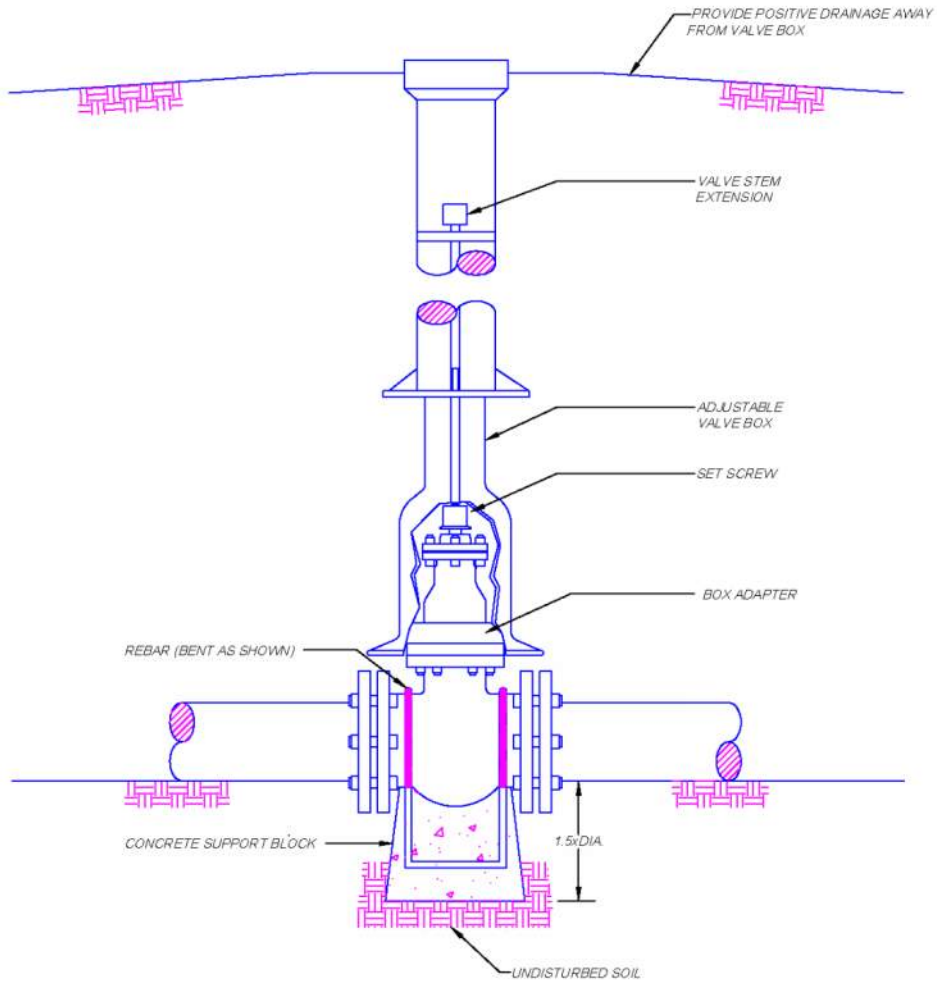

**GATE VALVE & BOX**  
**NOT TO SCALE**

CITY OF BOX ELDER  
STANDARD DETAIL  
GATE VALVE & BOX



DETAIL #W01

REVISED 01/2020

**DETAIL W02-HYDRANT WITH GATE VALVE & BOX**

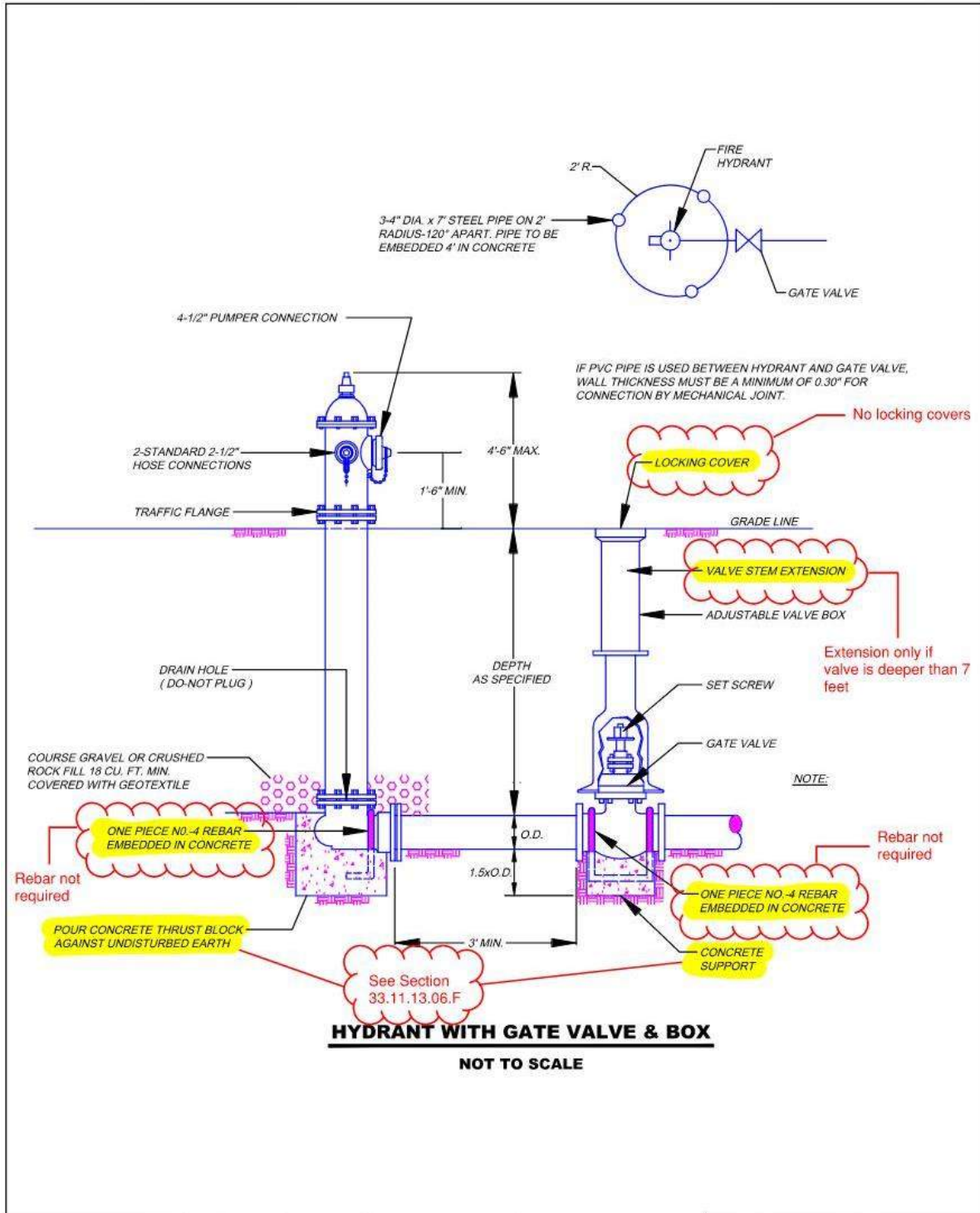

<p><b>CITY OF BOX ELDER</b></p> <p><b>STANDARD DETAIL W02</b></p> <p><b>HYDRANT WITH GATE VALVE &amp; BOX</b></p>		
DETAIL #W02	REVISED 01/2020	

**DETAIL W03-FLUSH RISER**

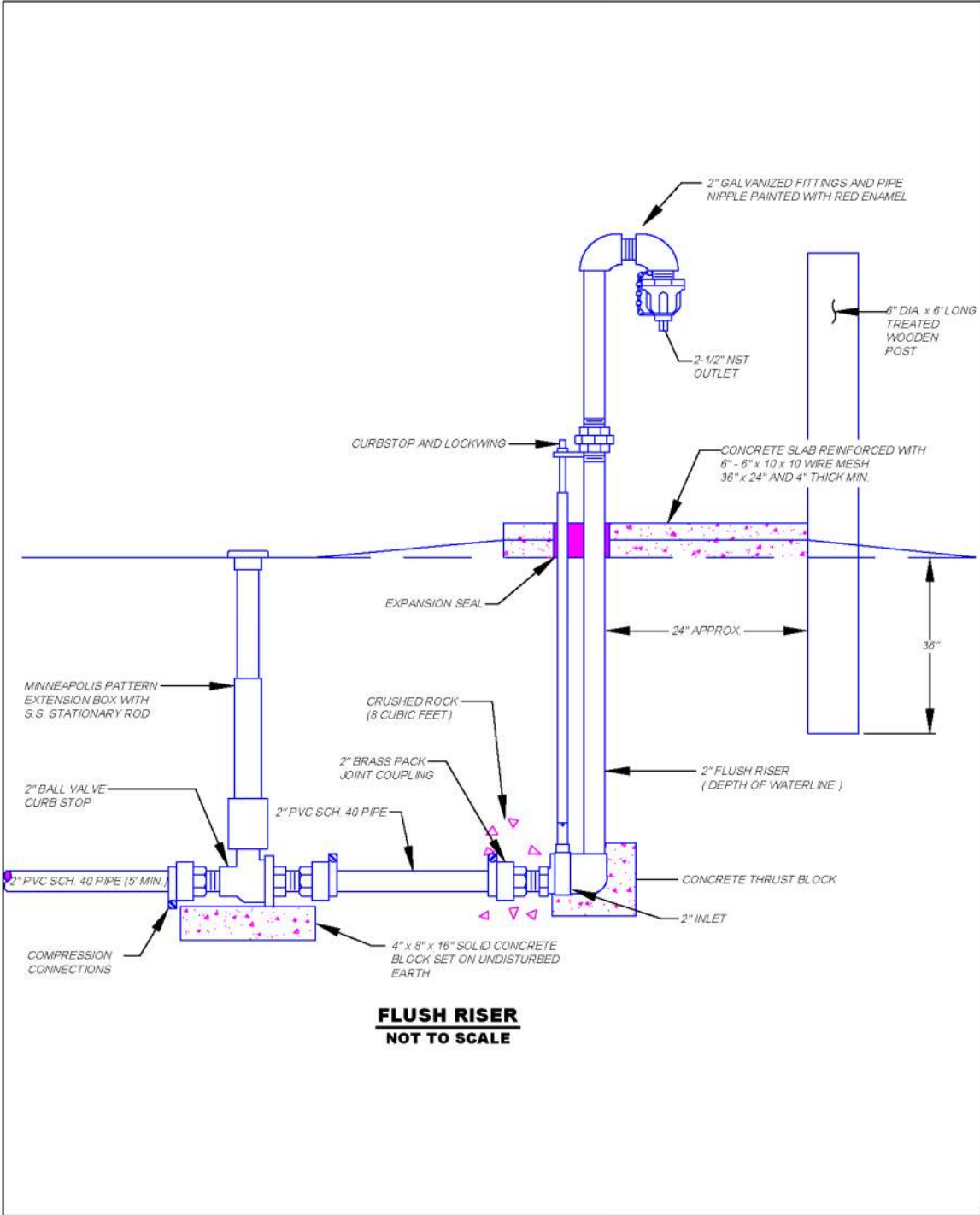

**FLUSH RISER  
NOT TO SCALE**

<p><b>CITY OF BOX ELDER</b> <b>STANDARD DETAIL</b> <b>FLUSH RISER</b></p>	
DETAIL #W03	REVISED 01/2020

## DETAIL W04-AIR VACUUM RELEASE VALVE PIT

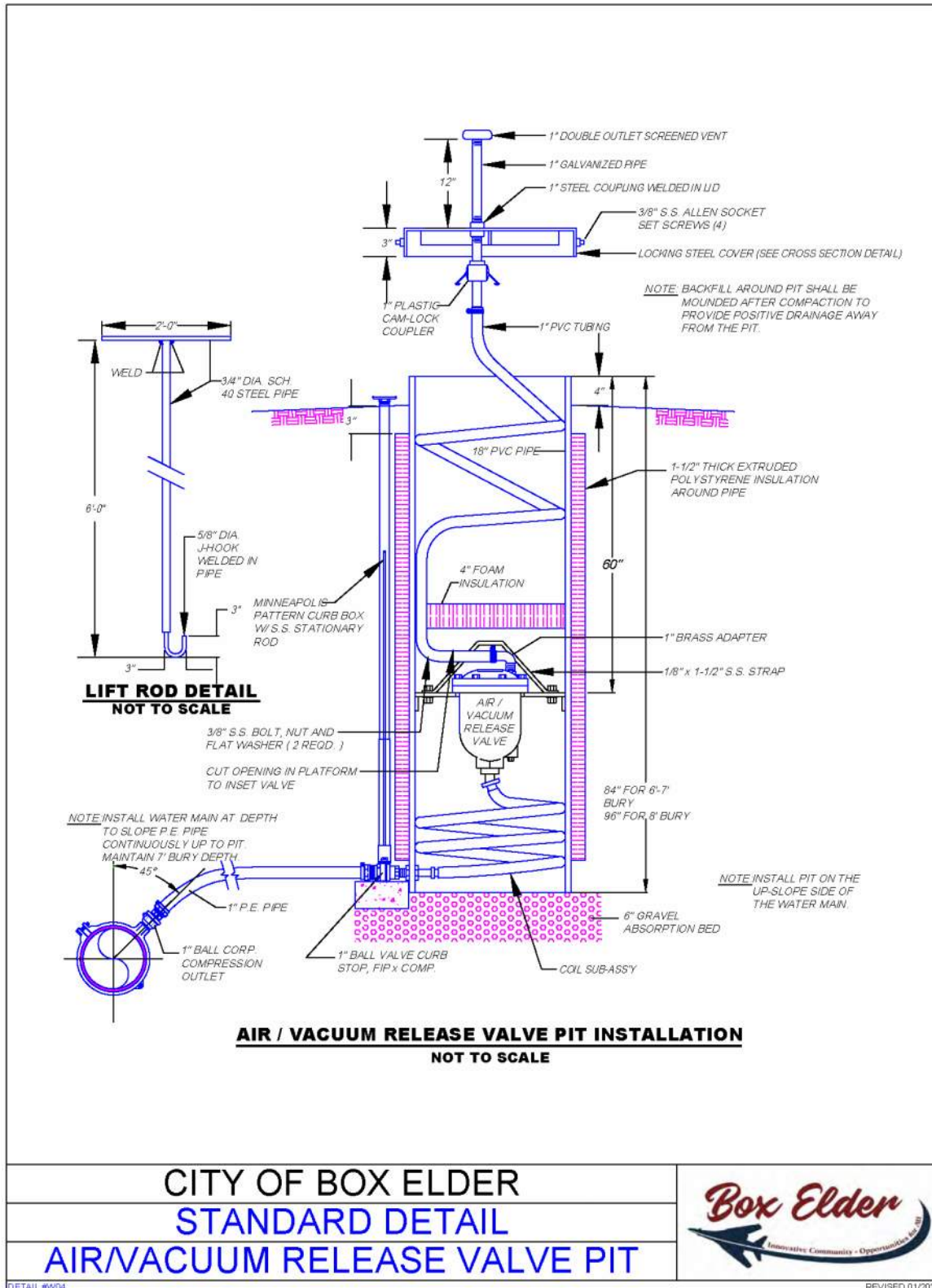

CITY OF BOX ELDER  
STANDARD DETAIL  
AIR/VACUUM RELEASE VALVE PIT



DETAIL #W04

REVISED 01/2020



**DETAIL W05-AIR VACUUM RELEASE PIT-COVER**

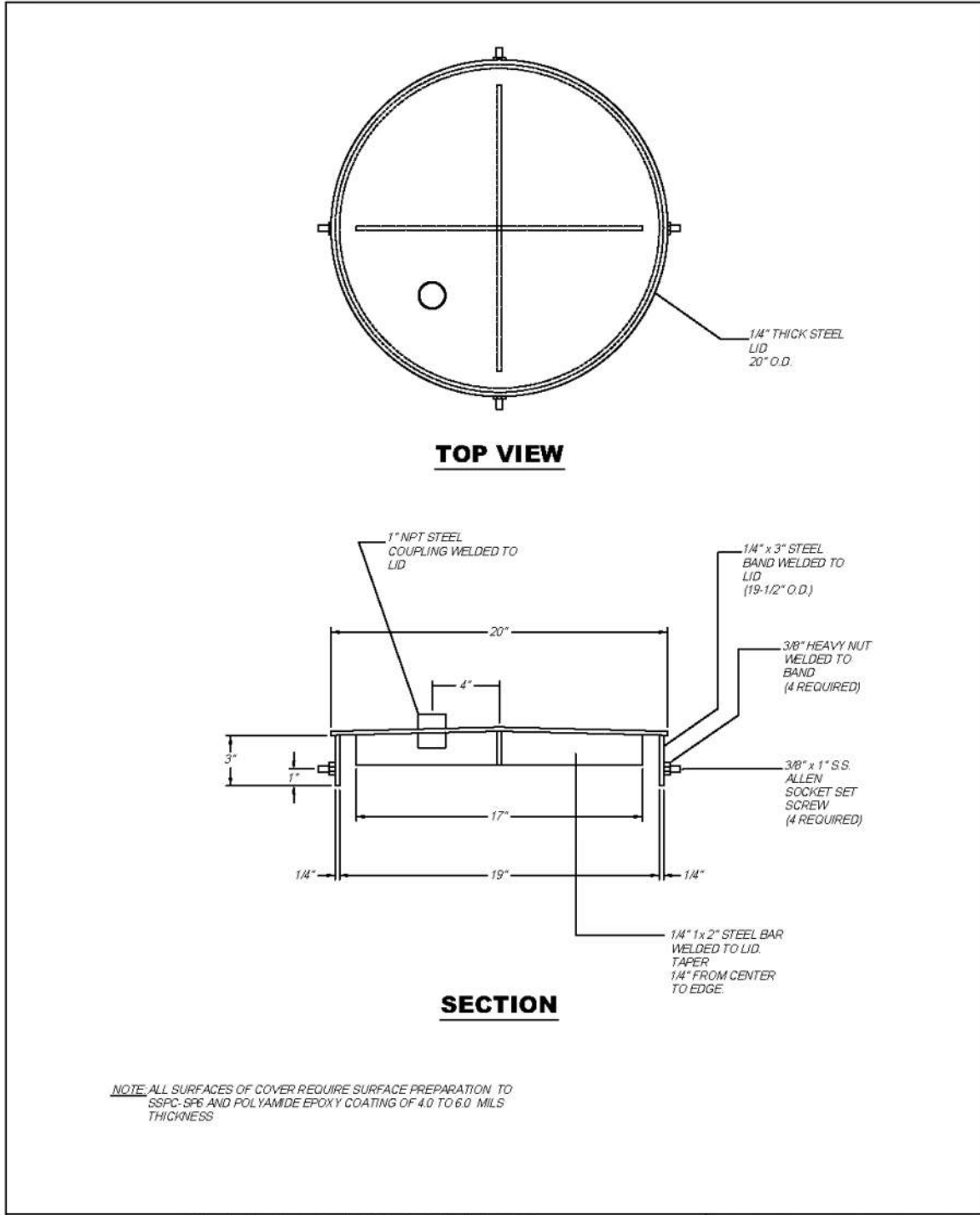

<p><b>CITY OF BOX ELDER</b></p> <p><b>STANDARD DETAIL</b></p> <p><b>AIR/VACUUM REL. VALVE PIT-COVER</b></p>	
DETAIL #W05	REVISED 01/20/20

## DETAIL W06-WATER SERVICE METER PIT

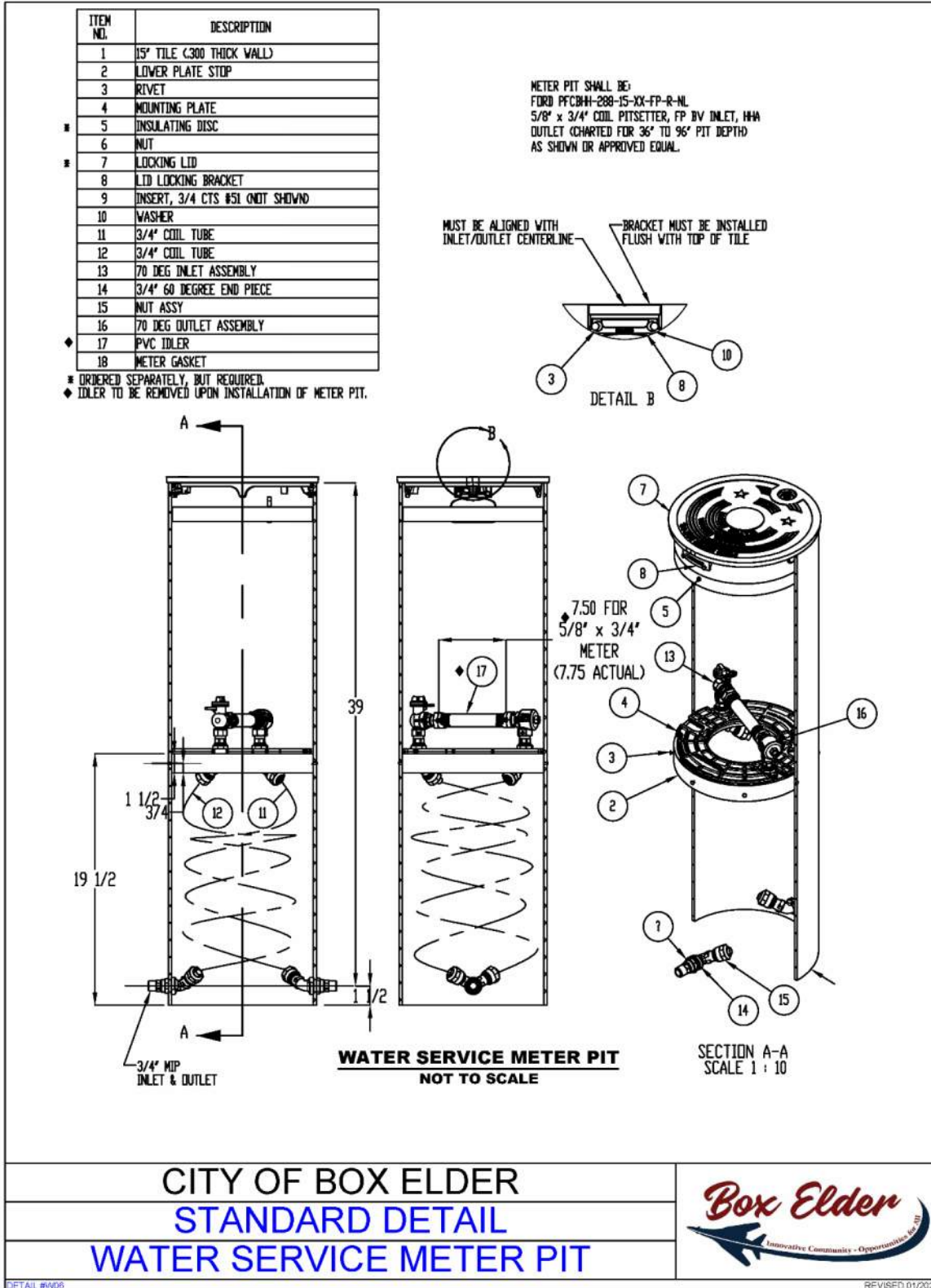

## DETAIL S01-STANDARD SEWER MANHOLE

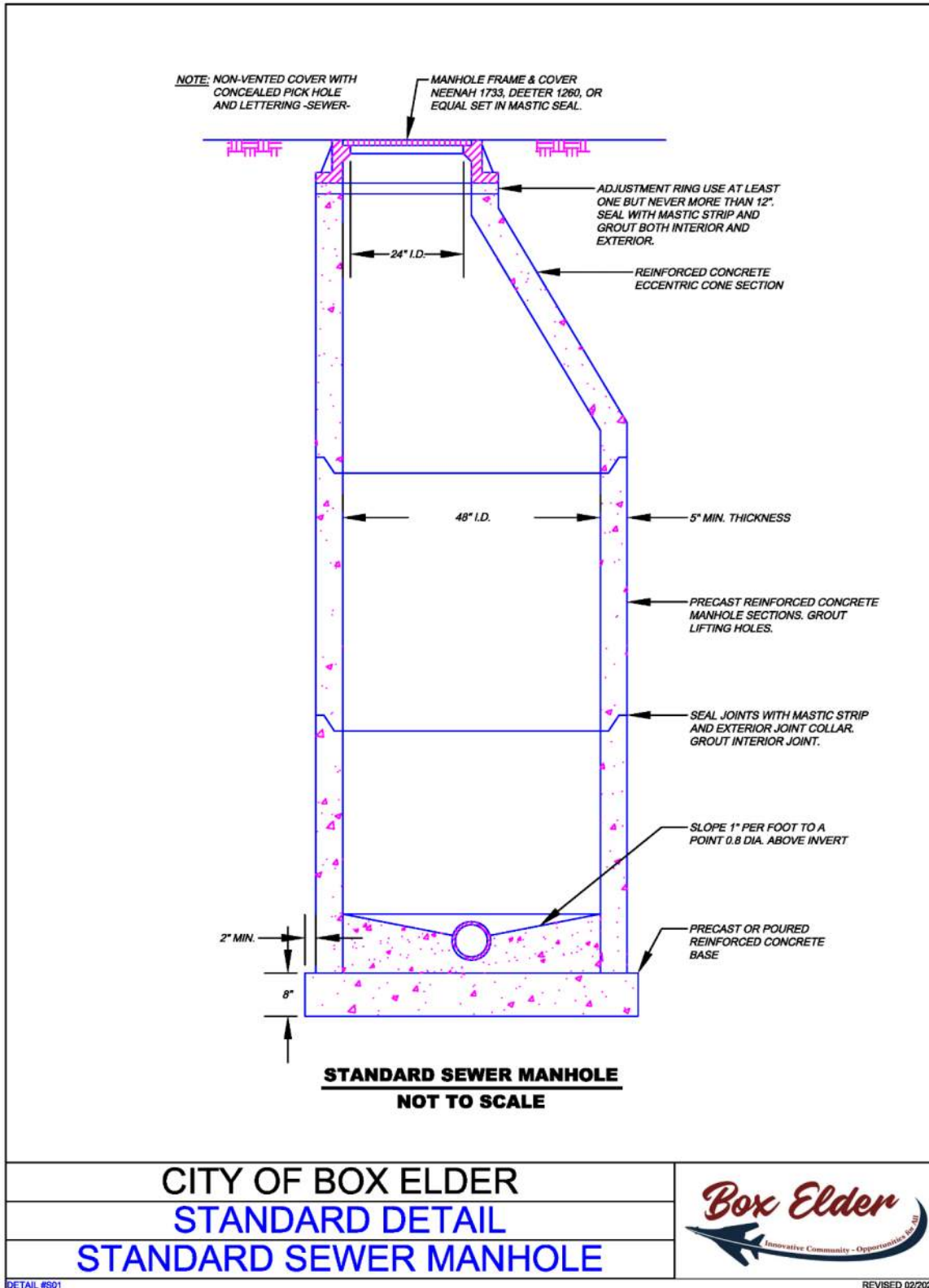

## DETAIL S02-SHALLOW MANHOLE SECTION

**NOTE:** 1. NON-VENTED COVER WITH CONCEALED PICK HOLE AND LETTERING-SEWER.  
 2. INSTALL EXTERIOR JOINT COLLAR ON MANHOLE SECTION JOINTS.

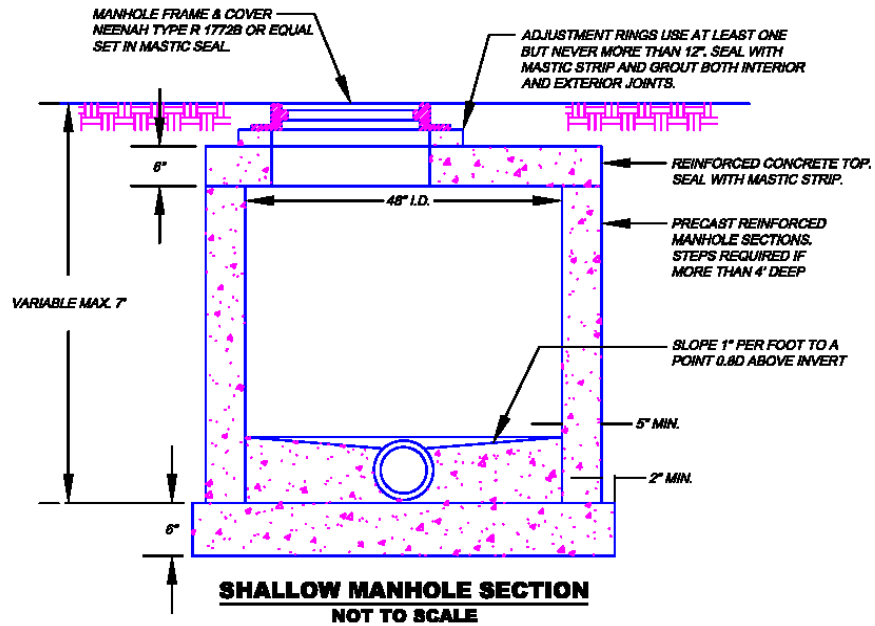

**CITY OF BOX ELDER**  
**STANDARD DETAIL**  
**SHALLOW MANHOLE SECTION**



DETAIL #802

REVISED 01/2020

# DETAIL S03-TYPICAL DROP MANHOLE

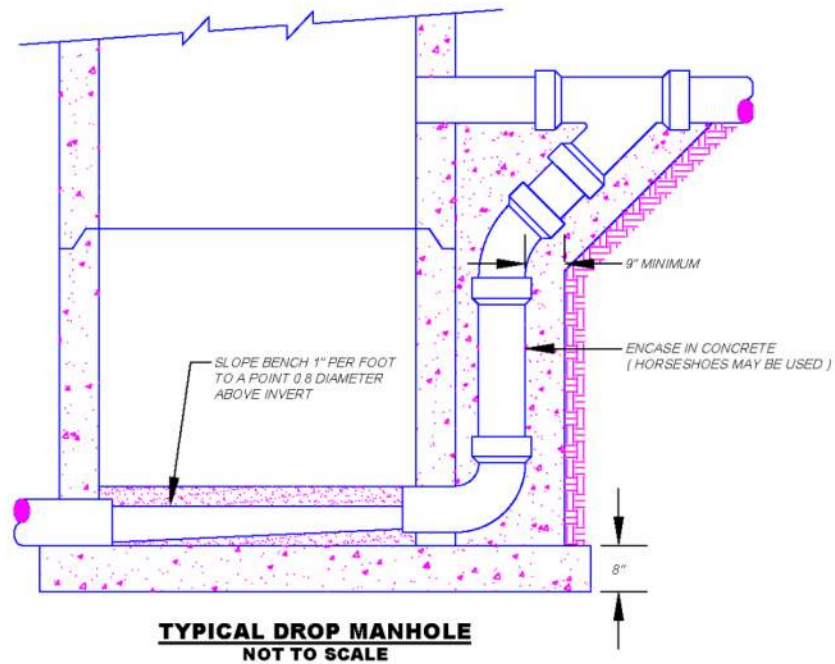

CITY OF BOX ELDER  
STANDARD DETAIL  
TYPICAL DROP MANHOLE



DETAIL #S03

REVISED 01/2020

## DETAIL S04-SEWER MAIN CLEANOUT

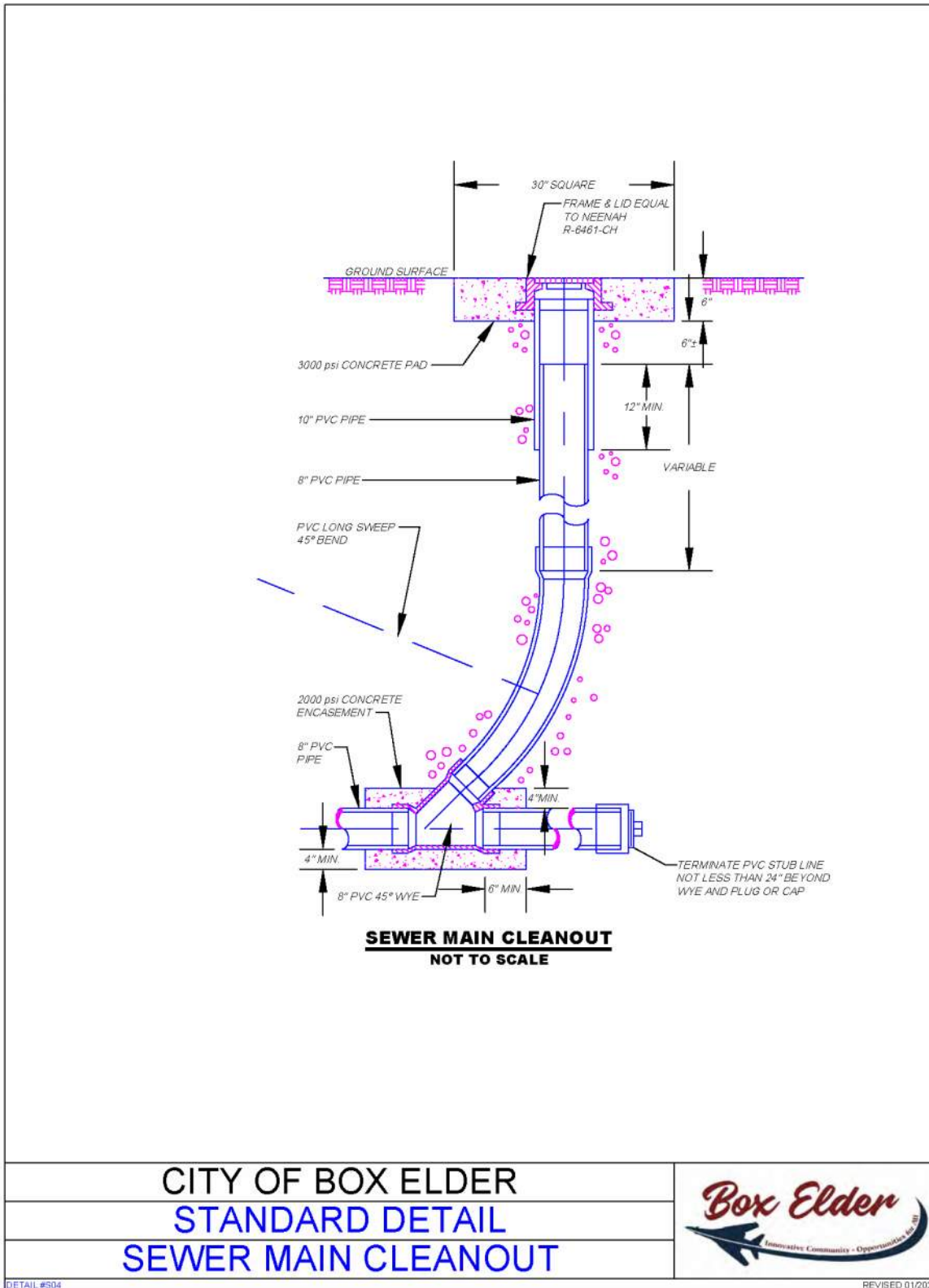

**DETAIL S06-SEWER SERVICE RISER**

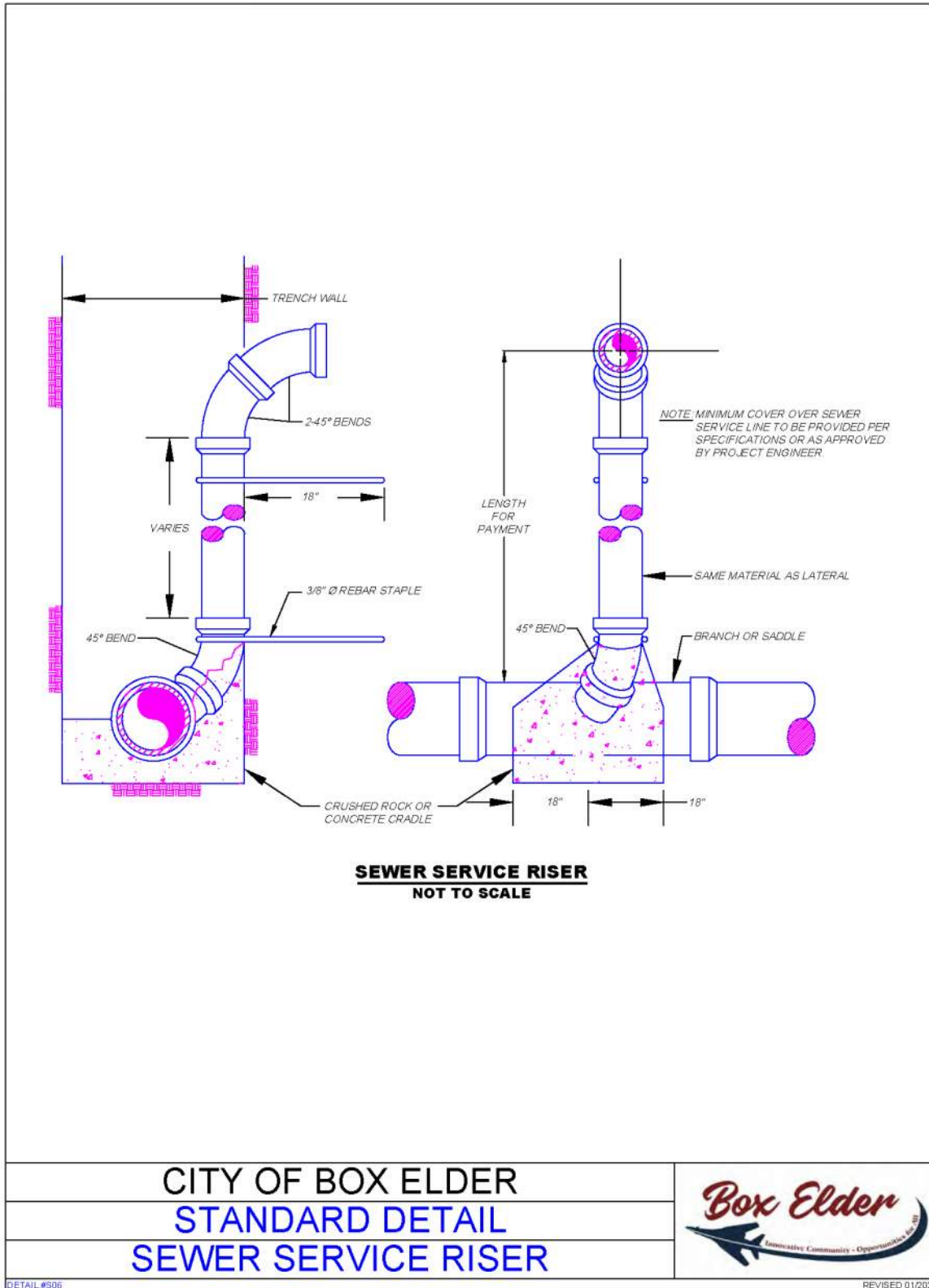

CITY OF BOX ELDER  
**STANDARD DETAIL**  
**SEWER SERVICE RISER**



DETAIL #S06

REVISED 01/2020

**DETAIL S07-SEWER SERVICE CONNECTION STUB**

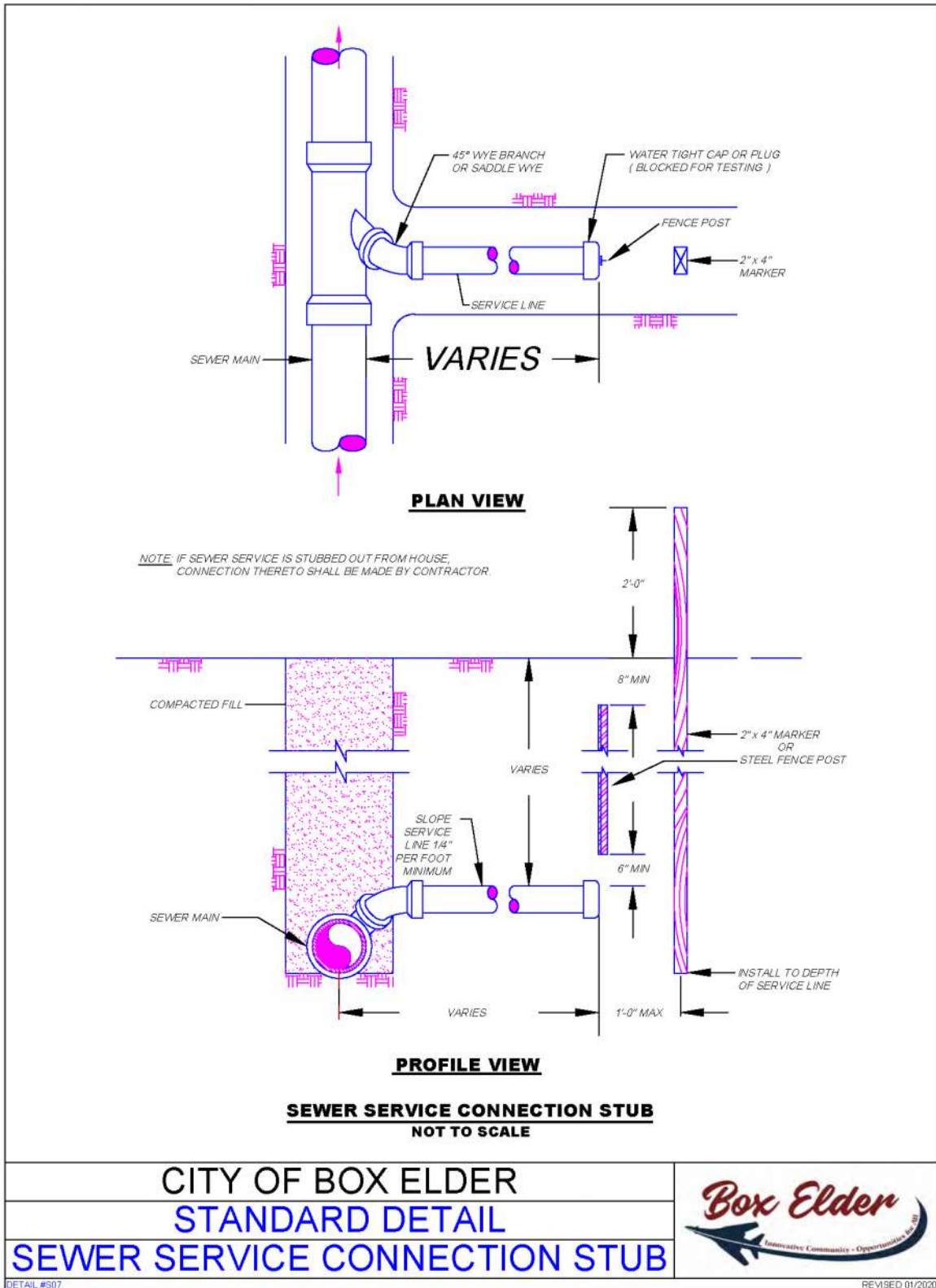



## DETAIL S08-SEWER SERVICE CLEANOUT

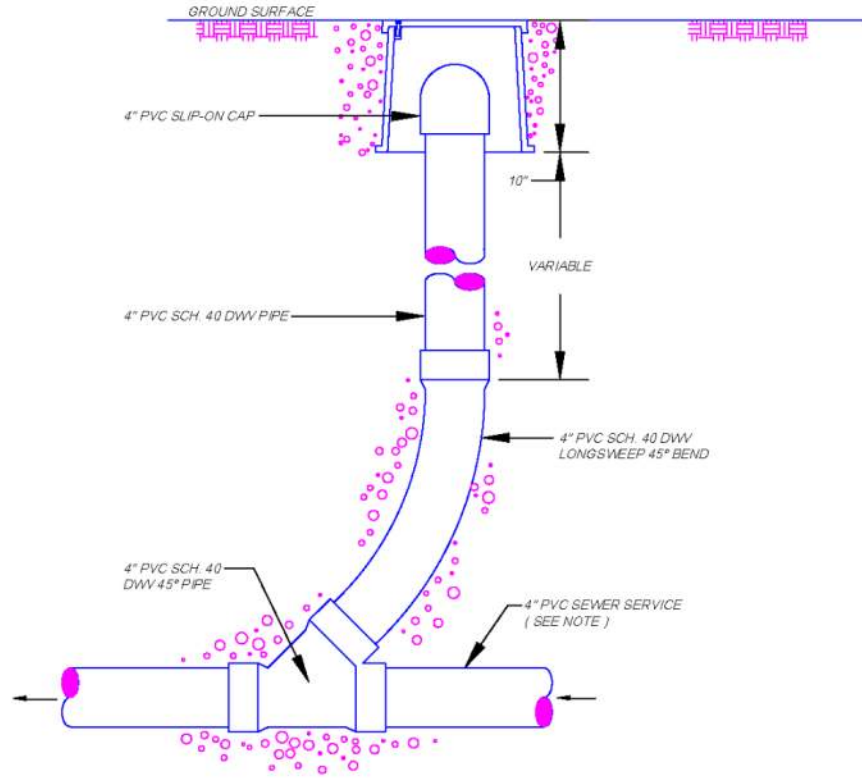

*NOTE: THE 4" PVC SEWER SERVICE SHALL BE SCHEDULE 40 DWV PIPE FOR INDIVIDUAL WASTE DISPOSAL SYSTEM. WHERE 4" PVC ASTM D-3034 PIPE IS ALLOWED FOR CONNECTION TO COMMUNITY SEWER SYSTEM, PVC ADAPTER BUSHINGS ARE REQUIRED ON THE WYE.*

**SEWER SERVICE CLEANOUT**  
**NOT TO SCALE**

**CITY OF BOX ELDER**  
**STANDARD DETAIL**  
**SEWER SERVICE CLEANOUT**



DETAIL #S08

REVISED 01/2020

**DETAIL S09-SEWER SERVICE CLEANOUT AT BEND**

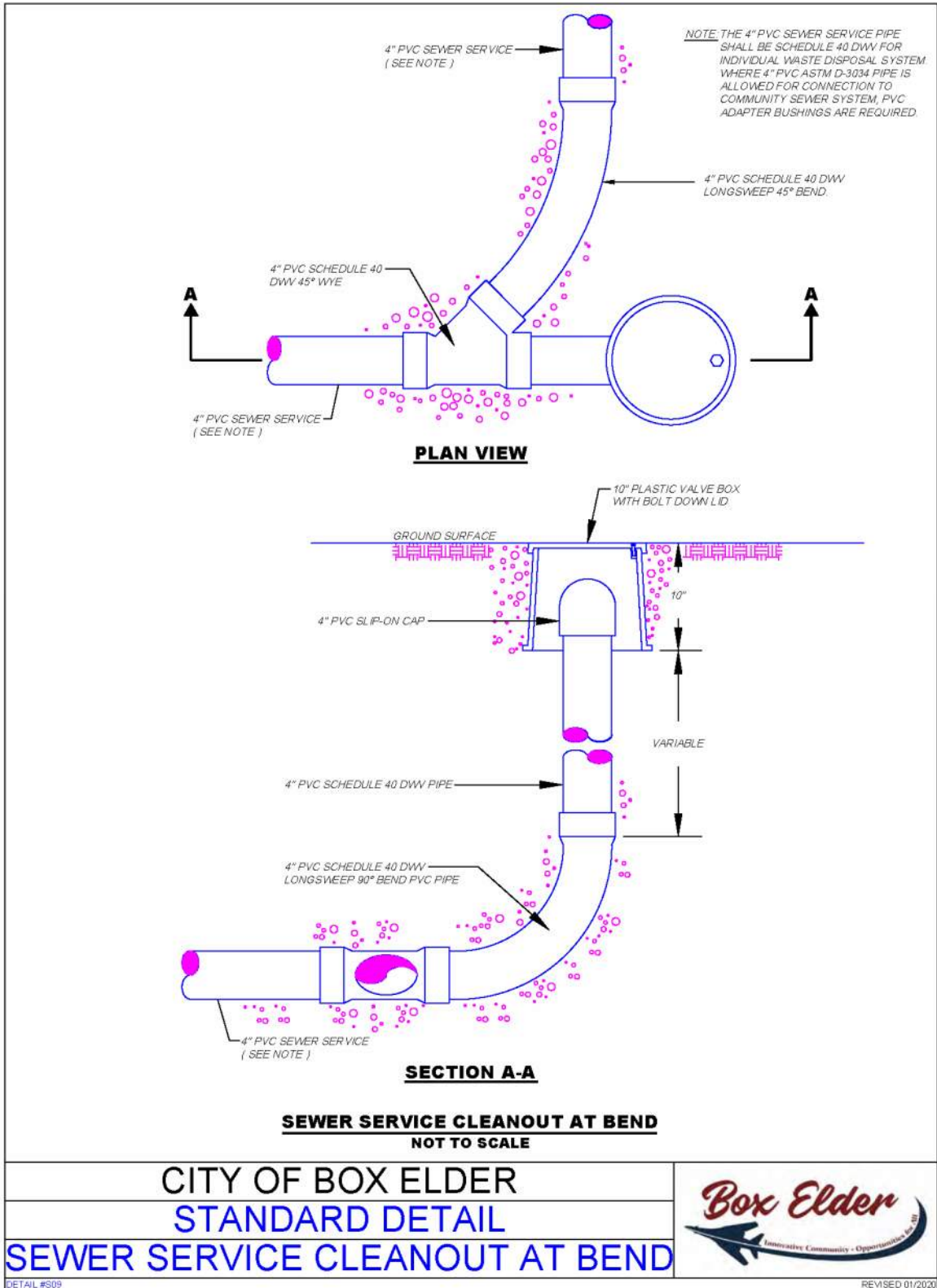

## DETAIL M01-TRENCH-TYPICAL & ALTERNATE

Updated per section 31.23.16.12 HAUNCHING AND INITIAL BACKFILL

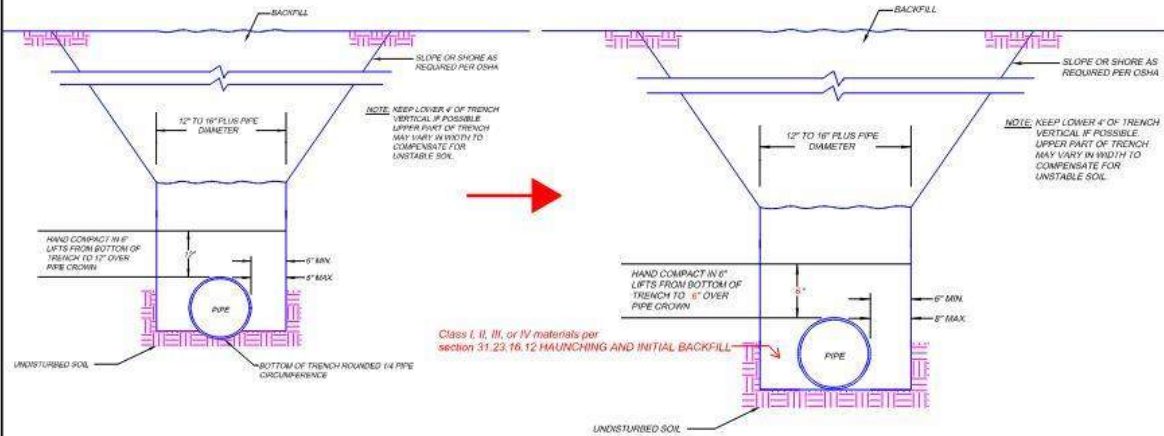

Updated per section 31.23.16.11 BEDDING

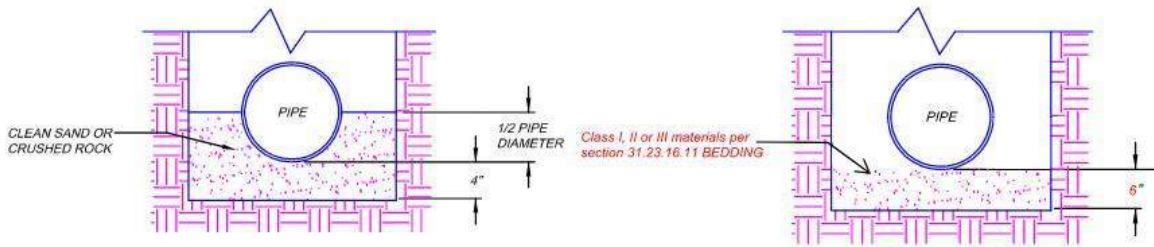

**CITY OF BOX ELDER**  
**STANDARD DETAIL M01**  
**TRENCH-TYPICAL & ALTERNATE**



DETAIL #M01

Revised 01/2024

**DETAIL M02-THRUST BLOCK SETTINGS**

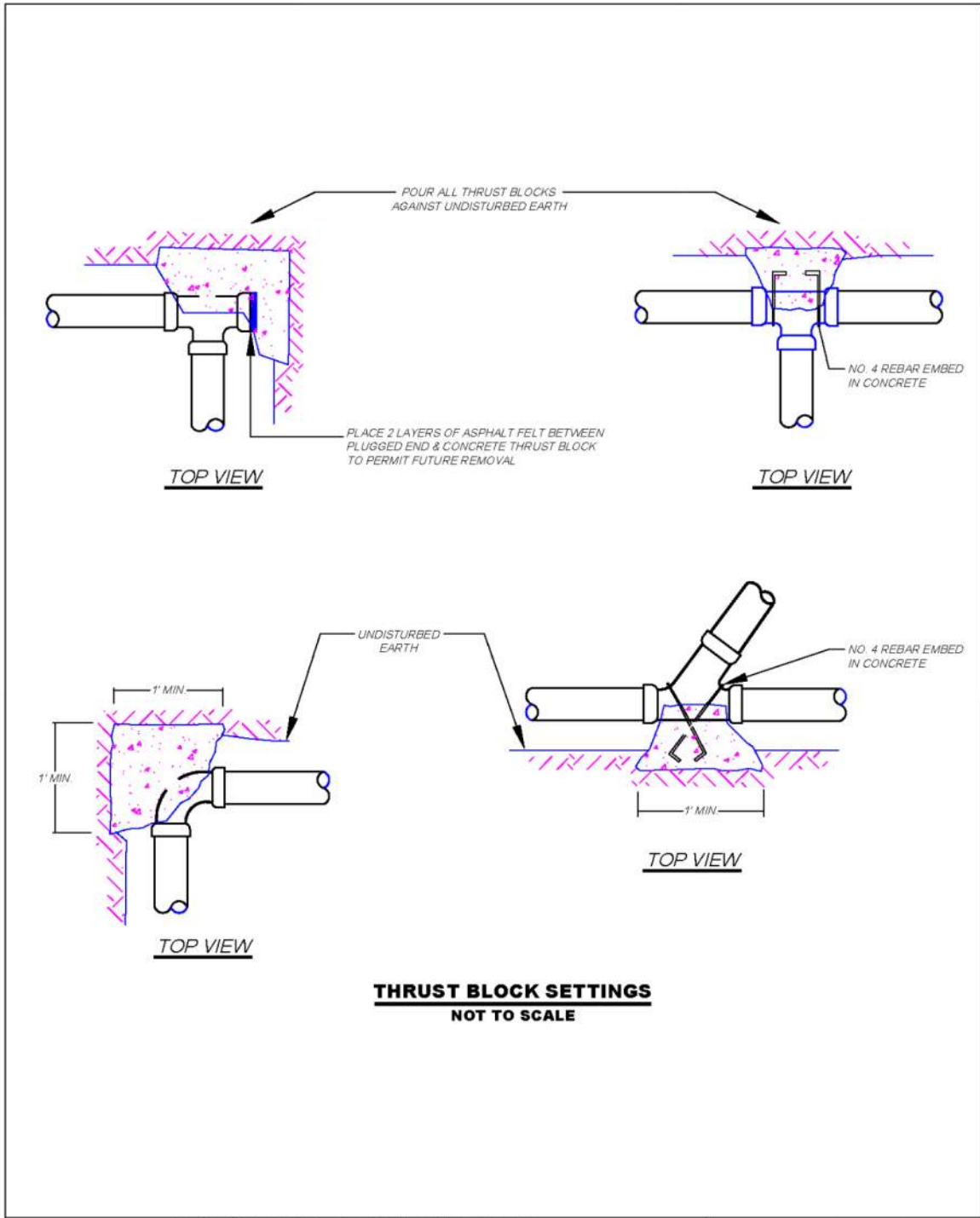

CITY OF BOX ELDER  
STANDARD DETAIL  
THRUST BLOCK SETTINGS



DETAIL #M02

REVISED 01/2020

## DETAIL M03-UTILITY MARKER & INSTALLATION

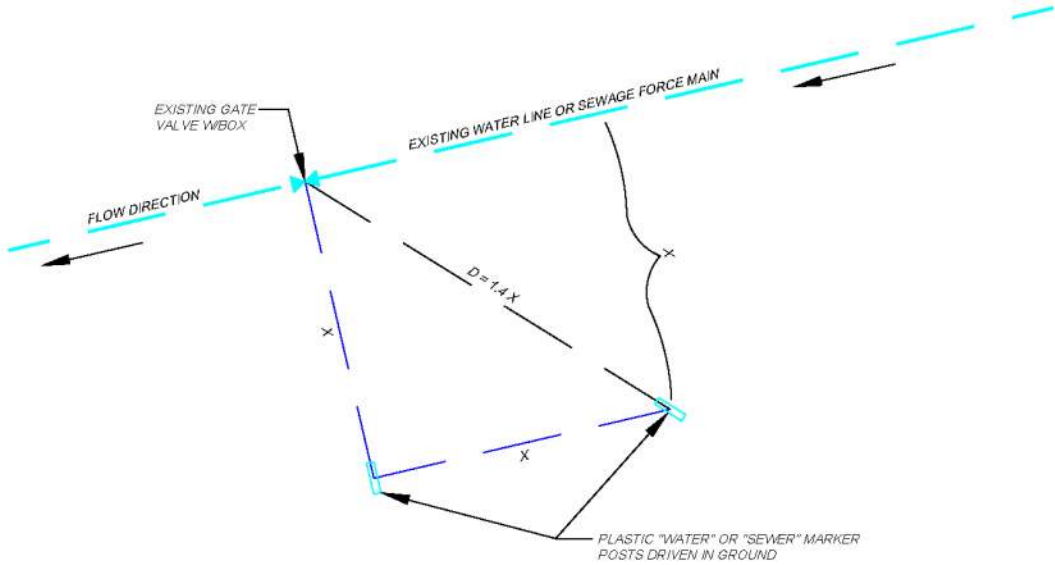

INSTALL PLASTIC MARKERS WITH FLAT SIDES POINTED IN DIRECTION OF VALVE OR MANHOLE. LOCATE MARKERS AT DISTANCES FROM THE VALVE OR MANHOLE TO FORM A 45° RIGHT TRIANGLE WITH ONE SHORT SIDE PERPENDICULAR TO THE VALVE OR MANHOLE. THE CONVERGING ANGLE OF THE MARKER SHALL POINT AT THE LINE AND ALSO IN THE FLOW DIRECTION. PLASTIC MARKER POST SHALL BE EQUAL TO 62" COLORED CARSONITE UTILITY MARKER AS MANUFACTURED BY AMETEK, INC., CARSON CITY, NEVADA. USE BLUE MARKERS FOR INLINE GATE VALVES AND AIR RELEASE MANHOLES ON WATER TRANSMISSION LINES. USE GREEN MARKERS FOR INLINE GATE VALVE AND AIR RELEASE MANHOLES ON SEWER FORCE MAINS. MARKERS ( GREEN ) CAN ALSO BE USED FOR SEWER MANHOLES FOR SPECIAL CIRCUMSTANCES.

### **UTILITY MARKER & INSTALLATION** NOT TO SCALE

CITY OF BOX ELDER  
STANDARD DETAIL  
UTILITY MARKER & INSTALLATION



DETAIL #M03

REVISED 01/2020

# DETAIL M04-HIGHWAY CROSSING

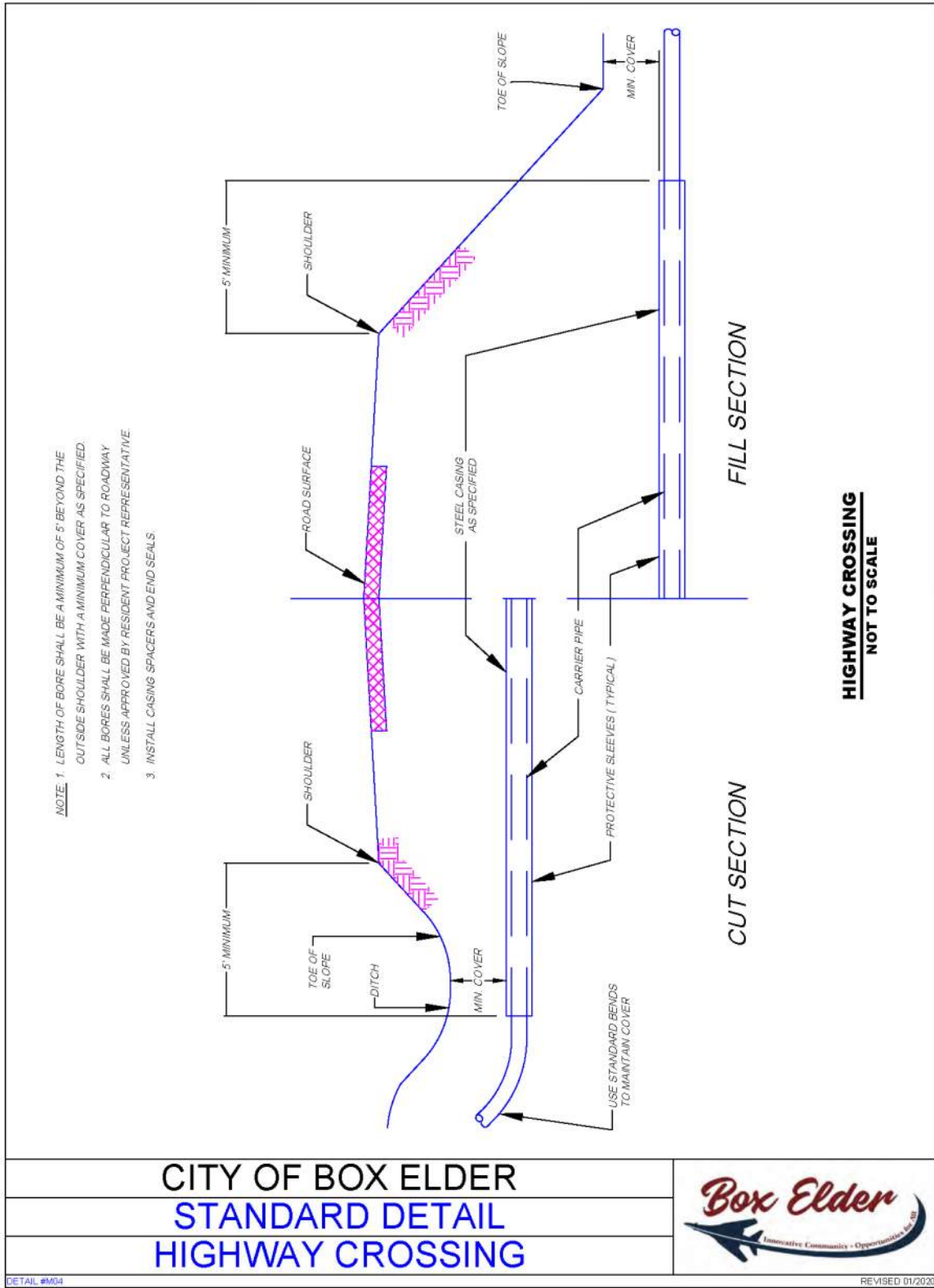

**HIGHWAY CROSSING  
NOT TO SCALE**

## DETAIL RC001-CULVERT-RCP-ROUND

### TOLERANCES IN DIMENSIONS

Diameter:  $\pm 1.5\%$  for 24" Dia. or less and  $+1\%$  or  $3/8"$  whichever is more for 27" Dia. or greater.  
 Diameters at joints:  $+3/16"$  for 30" Dia. or less and  $+1/4"$  for 36" or greater.  
 Length of joint (J):  $+1/4"$ .  
 Wall thickness (T): not less than design T by more than 5% or  $3/16"$ , whichever is greater.  
 Laying length: shall not underrun by more than  $1/2"$ .

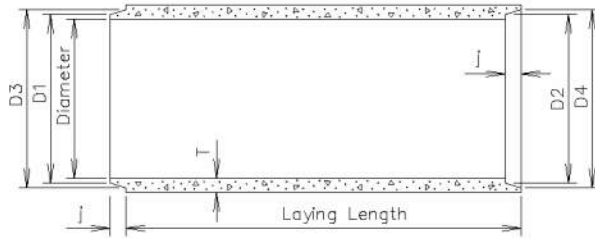

**LONGITUDINAL SECTION**

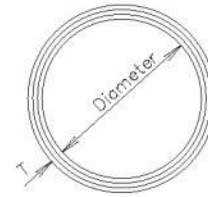

**END VIEW**

### GENERAL NOTES:

Not more than 2 four-foot sections shall be permitted near the ends of any culvert. Four-foot lengths shall be used only to secure the required length of culvert.

Diam. (in.)	Approx. Wt. /Ft. (lb.)	T (in.)	J (in.)	D1 (in.)	D2 (in.)	D3 (in.)	D4 (in.)
12	92	2	13/4	131/4	135/8	137/8	141/4
15	127	2 1/4	2	161/2	167/8	171/4	175/8
18	168	2 1/2	2 1/4	195/8	20	203/8	203/4
21	214	2 3/4	2 1/2	227/8	231/4	233/4	241/8
24	265	3	2 3/4	26	263/8	27	273/8
27	322	3 1/4	3	291/4	295/8	301/4	305/8
30	384	3 1/2	3 1/4	323/8	323/4	331/2	337/8
36	524	4	3 3/4	383/4	391/4	40	401/2
42	685	4 1/2	4	451/8	455/8	461/2	47
48	867	5	4 1/2	511/2	52	53	531/2
54	1070	5 1/2	4 1/2	577/8	583/8	593/8	597/8
60	1296	6	5	641/4	643/4	66	661/2
66	1542	6 1/2	5 1/2	705/8	711/8	721/2	73
72	1810	7	6	77	771/2	79	791/2
78	2098	7 1/2	6 1/2	833/8	837/8	855/8	861/8
84	2410	8	7	893/4	901/4	921/8	925/8
90	2740	8 1/2	7	953/4	961/4	981/8	985/8
96	2950	9	7	1021/8	1025/8	1041/2	105
102	3075	9 1/2	7 1/2	109	1091/2	1111/2	112
108	3870	10	7 1/2	1151/2	116	118	1181/2

**REINFORCED CONCRETE PIPE-ROUND**  
**NOT TO SCALE**

**CITY OF BOX ELDER**  
**STANDARD DETAIL**  
**CULVERT-RCP-ROUND**



DETAIL #RC001

REVISED 01/2020

## DETAIL RC002-CULVERT-RCP-ARCH

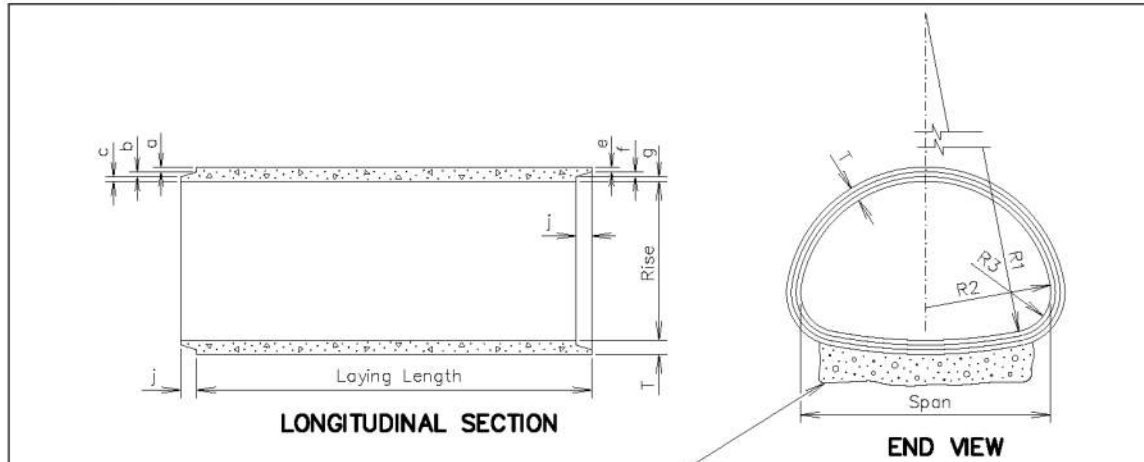

### TOLERANCES IN DIMENSIONS

Radial dimensions at joints:  $\pm 1/8"$  for 65" span or less and  $\pm 1/4"$  for longer spans.  
 Rise and Span:  $\pm 2\%$  of tabular values.  
 Length of Joint (J):  $\pm 1/4"$ .  
 Wall thickness (T): not less than design T by more than 5% or  $3/16"$ , whichever is greater.  
 Laying length: shall not underrun by more than  $1/2"$ .

Gravel Bedding Material shall be supplied for 102" to 169" spans. It shall be placed to a thickness of 6" (Min.)  $\times$  85% of the Span  $\times$  Length of culvert and shall conform to the gradation requirements for gravel surfacing except material may be screened or may be plan provided material.

* Size (in.)	Approx. Wt./Ft. (lb.)	Rise (in.)	Span (in.)	T (in.)	a (in.)	b (in.)	c (in.)	j (in.)	e (in.)	f (in.)	g (in.)	R1 (in.)	R2 (in.)	R3 (in.)
18	170	131/2	22	21/2	13/8	3/8	3/4	2	11/8	3/8	1	271/2	133/4	51/4
24	320	18	281/2	31/2	15/8	1/2	13/8	3	13/8	1/2	15/8	1011/16	143/4	45/8
30	450	221/2	361/4	4	113/16	5/8	19/16	31/2	19/16	5/8	113/16	51	183/4	61/8
36	600	265/8	433/4	41/2	2	3/4	13/4	4	13/4	3/4	2	62	221/2	61/2
42	740	315/16	511/8	41/2	2	3/4	13/4	4	13/4	3/4	2	73	261/4	73/4
48	890	36	581/2	5	21/4	3/4	2	5	2	3/4	21/4	84	30	87/8
54	1100	40	65	51/2	21/2	3/4	21/4	5	21/4	3/4	21/2	921/2	333/8	10
60	1400	45	731/2	6	35/16	3/4	115/16	5	23/4	3/4	21/2	105	371/2	11
72	1900	54	88	7	313/16	1	23/16	6	31/4	1	23/4	126	45	135/16
84	2500	62	102	8	41/8	1	27/8	6	31/2	1	31/2	1621/2	52	141/2
96	3300	78	1223/8	9	41/2	1	31/2	7	4	1	4	218	62	20
108	4200	88	1381/2	10	5	1	4	7	41/2	1	41/2	269	70	22
120	5100	967/8	154	11	51/2	1	41/2	7	5	1	5	3013/8	78	24
132	5100	1061/2	1683/4	10		1	4	7	41/2	1	41/2	329	855/8	267/8

\* Equivalent Diameter of Circular R. C. P.

### GENERAL NOTES:

Not more than 2 four-foot sections shall be permitted near the ends of any culvert. Four-foot lengths shall be used only to secure the required length of culvert.

### REINFORCED CONCRETE PIPE-ARCH NOT TO SCALE

**CITY OF BOX ELDER**  
**STANDARD DETAIL**  
**CULVERT-RCP-ARCH**



DETAIL #RC002

REVISED 01/2020



**DETAIL RC003-CULVERT-RCP BEND-ROUND (SHORT)**

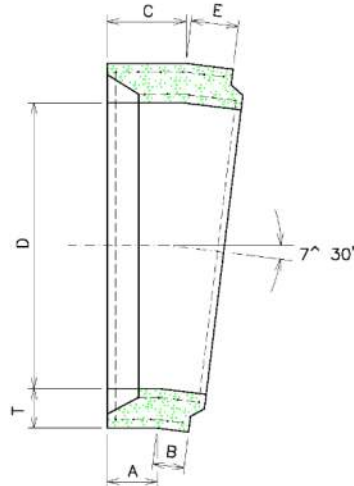

D (in.)	Laying Length at Center of Pipe (in.)	Laying Length at Outside of Curve (in.)	T (in.)	A (in.)	B (in.)	C (in.)	E (in.)	Radius of Curve (ft.)	Weight of Section (lbs.)
12	7 3/4	B	2	4 3/4	2	5 3/4	3	4.9	70
15	11 1/4	12 1/2	2 1/4	5 1/4	4 3/4	6 1/2	6	7.2	120
18	12 1/8	13 5/8	2 1/2	5 1/2	5 1/8	7	6 5/8	7.7	170
21	9 1/2	11 1/4	2 3/4	5 1/2	2 1/4	7 1/4	4	6.1	170
24	9 13/16	11 3/4	3	5 9/16	2 5/8	7 1/2	4 1/4	6.2	215
27	9 11/16	12 1/8	3 1/4	5 7/16	2 5/16	7 5/8	4 1/2	6.2	260
30	10	12 3/8	3 1/2	5 5/16	2 5/16	7 11/16	4 11/16	6.4	320
33	11 3/16	13 7/8	3 3/4	5 15/16	2 9/16	8 5/8	5 1/4	7.1	420
36	12 3/16	15 1/16	4	6 1/2	2 5/16	9 3/8	5 11/16	7.7	530
42	14 1/16	17 1/2	4 1/2	6 13/16	3 13/16	10 5/16	7 3/16	8.9	800
48	16 1/16	20 1/4	5	7 15/16	4 11/16	11 3/4	8 1/2	10.5	1190
54	18 1/16	22 5/16	5 1/2	7 5/8	6 3/16	11 7/8	10 7/16	11.5	1600
60	20 1/2	25 1/4	6	8 5/8	7 1/8	13 3/8	11 7/8	13.0	2210
66	21 5/8	26 15/16	6 1/2	9	7 3/8	14 5/16	12 5/8	13.8	2790
72	22 5/8	28 1/4	7	9 3/8	7 5/8	13 1/4	15	14.4	3420

**REINFORCED CONCRETE PIPE BEND-ROUND (SHORT RADIUS)**  
**NOT TO SCALE**

**CITY OF BOX ELDER**  
**STANDARD DETAIL**  
**CULVERT-RCP BEND-ROUND (SHORT)**



DETAIL #RC003

REVISED 01/2020

## DETAIL RC004-CULVERT-RCP BEND-ROUND (LONG)

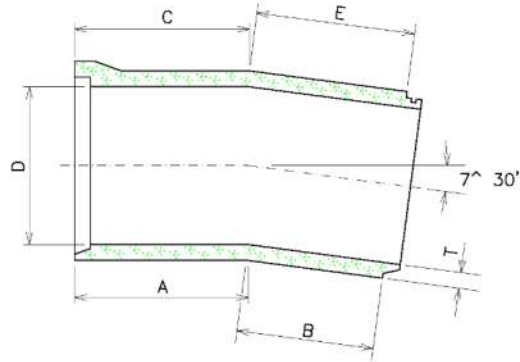

**GENERAL NOTE:**

Centerline laying length: 4'-0"  
 Radius of Curve: 30.5'

D (in.)	T (in.)	A (in.)	B (in.)	C (in.)	E (in.)	Weight of Section (lbs.)
12	2	36 15/32	10 15/32	37 17/32	11 17/32	366
15	2 1/4	36 1/2	10 1/4	37 3/4	11 1/2	508
18	2 1/2	24 1/2	22	26	23 1/2	672
21	2 3/4	24 1/2	21 3/4	26 1/4	23 1/2	856
24	3	25 1/32	21 1/32	26 31/32	22 31/32	1060
27	3 1/4	25 1/32	20 25/32	27 7/32	22 31/32	1288
30	3 1/2	25 1/32	20 17/32	27 15/32	22 31/32	1536
33	3 3/4	24 15/16	20 7/16	27 9/16	23 1/16	1808
36	4	24 13/16	20 5/16	27 11/16	23 3/16	2096
42	4 1/2	24 27/32	19 27/32	28 5/32	23 5/32	2740
48	5	24 19/32	19 19/32	28 13/32	23 13/32	3468
54	5 1/2	24 5/8	19 1/8	29 11/32	23 3/8	4280
60	6	24 21/32	18 21/32	29 11/32	23 11/32	5184
66	6 1/2	24 11/16	18 3/16	29 13/16	23 5/16	6168
72	7	24 1/8	18 1/8	29 7/8	23 7/8	7240
84	8	24 1/4	17 1/4	30 3/4	23 3/4	9640
96	9	23 5/16	17 5/16	30 11/16	24 11/16	12400

**REINFORCED CONCRETE PIPE BEND-ROUND (LONG RADIUS)**  
**NOT TO SCALE**

<b>CITY OF BOX ELDER</b> <b>STANDARD DETAIL</b> <b>CULVERT-RCP BEND-ROUND (LONG)</b>	
DETAIL #RC004	REVISED 01/2020

## DETAIL RC005-CULVERT-RCP FLARED ENDS-ROUND

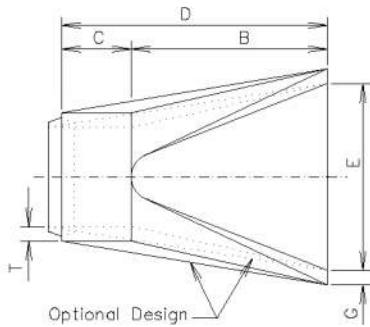

**TOP VIEW**

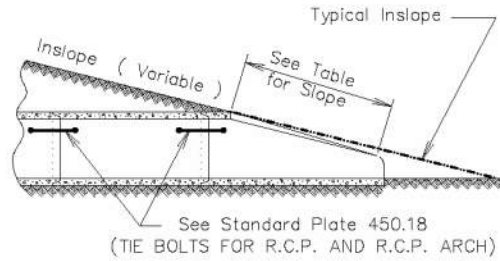

**SLOPE DETAIL**

**GENERAL NOTES:**

Lengths of concrete pipe shown on plan sheets are between flared ends only.

Construction of R.C.P. Flared End shall conform to the requirements of Section 990 of the Specifications.

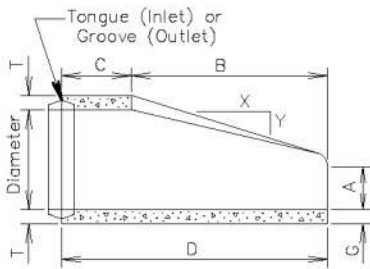

**LONGITUDINAL SECTION**

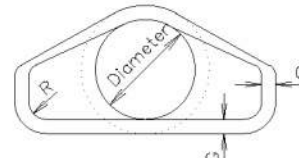

**END VIEW**

Dia. (in.)	Approx. Wt. of Section (lbs.)	Approx. Slope (X to Y)	T (in.)	A (in.)	B (in.)	C (in.)	D (in.)	E (in.)	G (in.)	R (in.)
12	530	2.4: 1	2	4	24	48 7/8	72 7/8	24	2	11/2
15	740	2.4: 1	2 1/4	6	27	46	73	30	2 1/4	11/2
18	990	2.3: 1	2 1/2	9	27	46	73	36	2 1/2	11/2
21	1280	2.4: 1	2 3/4	9	36	37 1/2	73 1/2	42	2 3/4	11/2
24	1520	2.5: 1	3	9 1/2	43 1/2	30	73 1/2	48	3	11/2
27	1930	2.5: 1	3 1/4	10 1/2	49 1/2	24	73 1/2	54	3 1/4	11/2
30	2190	2.5: 1	3 1/2	12	54	19 3/4	73 3/4	60	3 1/2	11/2
36	4100	2.5: 1	4	15	63	34 3/4	97 3/4	72	4	11/2
42	5380	2.5: 1	4 1/2	21	63	35	98	78	4 1/2	11/2
48	6550	2.5: 1	5	24	72	26	98	84	5	11/2
54	8240	2: 1	5 1/2	27	65	33 1/4	98 1/4	90	5 1/2	11/2
60	8730	1.9: 1	6	35	60	39	99	96	5	11/2
66	10710	1.7: 1	6 1/2	30	72	27	99	102	5 1/2	11/2
72	12520	1.8: 1	7	36	78	21	99	108	6	11/2
78	14770	1.8: 1	7 1/2	36	90	21	111	114	6 1/2	11/2
84	18160	1.6: 1	8	36	90 1/2	21	111 1/2	120	6 1/2	11/2
90	20900	1.5: 1	8 1/2	41	87 1/2	24	111 1/2	132	6 1/2	6

**REINFORCED CONCRETE PIPE FLARED ENDS-ROUND**

NOT TO SCALE

**CITY OF BOX ELDER  
STANDARD DETAIL  
CULVERT-RCP FLARED ENDS-ROUND**



DETAIL #RC005

REVISED 01/2020

## DETAIL RC006-CULVERT-RCP FLARED ENDS-ARCH

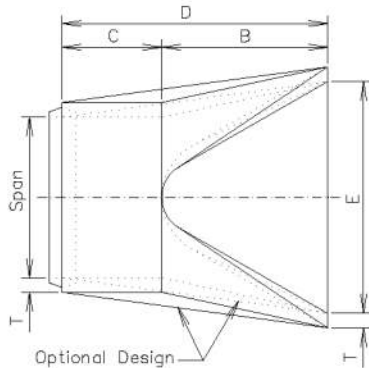

**TOP VIEW**

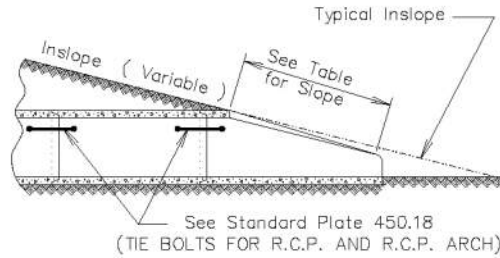

**SLOPE DETAIL**

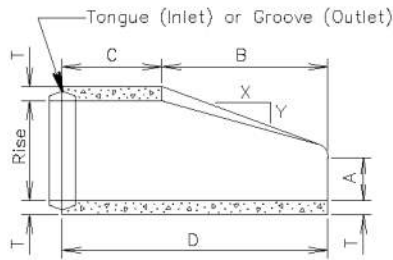

**LONGITUDINAL SECTION**

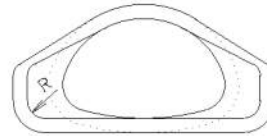

**END VIEW**

**GENERAL NOTES:**

Lengths of concrete pipe shown on plan sheets are between flared ends only.

Construction of R. C. P. Arch Flared End shall conform to the requirements of Section 990 of the Specifications.

* Size (in.)	Approximate Weight of Section (lbs.)	Rise (in.)	Span (in.)	Slope (X:Y)	T (in.)	A (in.)	B (in.)	C (in.)	D (in.)	E (in.)	R (in.)
18	1100	131/2	22	3: 1	21/2	7	27	45	72	36	2
24	1750	18	281/2	3: 1	31/2	81/2	39	33	72	48	3
30	3300	221/2	361/4	3: 1	4	91/2	50	46	96	60	3
36	4350	265/8	433/4	3: 1	41/2	111/8	60	36	96	72	6
42	5250	315/16	511/8	3: 1	41/2	513/16	60	36	96	78	6
48	6400	36	581/2	3: 1	5	21	60	36	96	84	6
54	7850	40	65	3: 1	51/2	251/2	60	36	96	90	6
60	9500	45	731/2	3: 1	6	31	60	36	96	96	6
72	13550	54	88	2: 1	7	31	60	39	99	120	6
84	17950	62	102	2: 1	8	281/2	83	19	102	144	6

\*Equivalent Diameter of Circular R. C. P.

**REINFORCED CONCRETE PIPE FLARED ENDS-ARCH  
NOT TO SCALE**

<b>CITY OF BOX ELDER</b>
<b>STANDARD DETAIL</b>
<b>CULVERT-RCP FLARED ENDS-ARCH</b>



DETAIL #RC006

REVISED 01/2020

## DETAIL RC007-CULVERT-RCP SAFETY ENDS

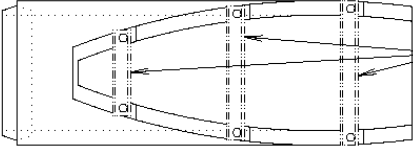

**TOP VIEW**

If bars are specified in the plans then provide HSS 2.5X2.5X.1875 Structural Steel Tubing in conformance with ASTM A500, Grade B or 3" Diameter Schedule 40 Pipe in conformance with ASTM A53, Grade B.

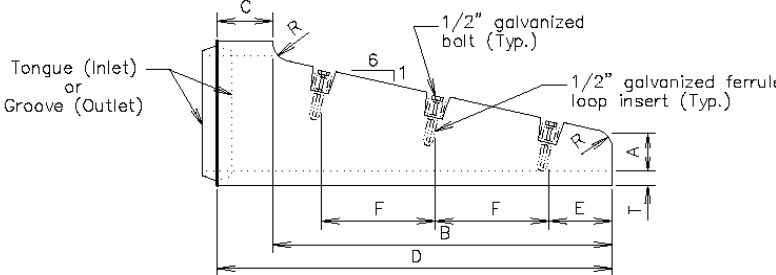

**SIDE VIEW**

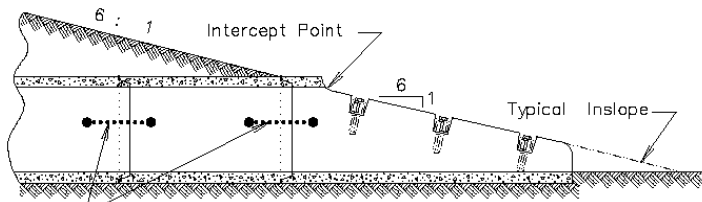

**ELEVATION VIEW**

Tie Bolt (Typ.)  
See Standard Plate 450.18

Dia. (in.)	T (in.)	R (in.)	A (in.)	B (in.)	C (in.)	D (in.)	E (in.)	F (in.)	No. Sections	No. Bars
<b>FOR CIRCULAR PIPE</b>										
15	21/4	3	6	48	9	57	6	18	1	3
18	21/2	3	6	69	9	78	9	24	1	3
*24	3	3	6	111	9	120	6	24	1 or 2	5
<b>FOR ARCH PIPE</b>										
**18	21/2	1	6	39	33	72	6	24	1	2

\* The use of 2 sections must be an approved design.  
 \*\* Equivalent Diameter of Circular R. C. P.

**GENERAL NOTES:**

The length of concrete pipe shown on the plans is between safety ends.

Safety ends without bars are acceptable with or without the bar notches.

Bars shall be galvanized after fabrication in accordance with ASTM A123.

**REINFORCED CONCRETE PIPE SAFETY ENDS**  
NOT TO SCALE

**CITY OF BOX ELDER**

**STANDARD DETAIL**

**CULVERT-RCP SAFETY ENDS**



DETAIL #RC007
REVISED 01/2020

## DETAIL RC008-CULVERT-RCP SLOPED ENDS-ROUND

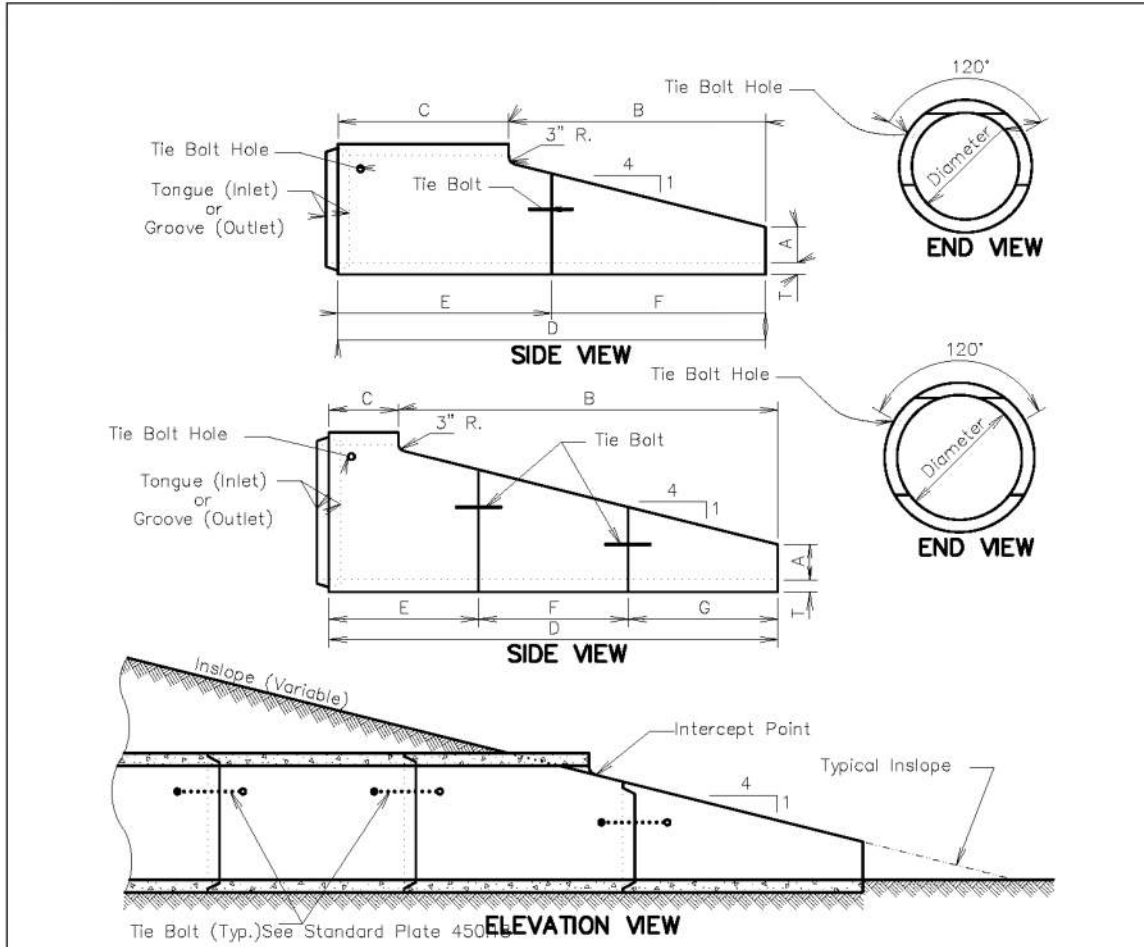

Dia. (in.)	T (in.)	A (in.)	B (in.)	C (in.)	D (in.)	E (in.)	F (in.)	G (in.)
36	4	12	86.5	57.5	144	72	72	
42	4.5	12	110.5	33.5	144	72	72	
48	5	12	134.5	33.5	168	96	72	
54	5.5	12	158.5	33.5	192	96	96	
60	6	12	182.5	33.5	216	72	72	72

**GENERAL NOTE:**

The length of concrete pipe shown in the construction plans is between sloped ends. If bars are specified in the plans, then the bar assemblies shall be constructed in accordance with Standard Plate 450.15.

**REINFORCED CONCRETE PIPE SLOPED ENDS-ROUND**  
**NOT TO SCALE**

**CITY OF BOX ELDER**  
**STANDARD DETAIL**  
**CULVERT-RCP SLOPED ENDS-ROUND**

DETAIL #RC008

REVISED 01/2020

**DETAIL RC009-CULVERT-RCP SLOPED ENDS-ARCH**

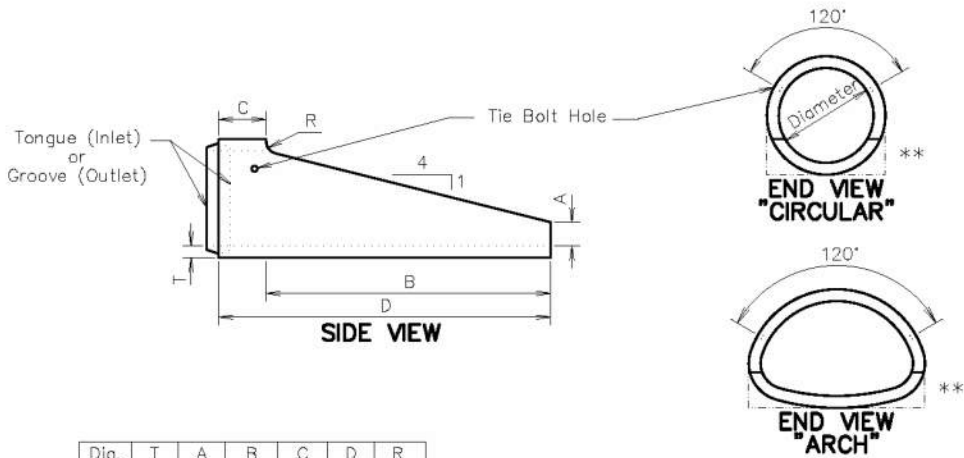

Dia. (in.)	T (in.)	A (in.)	B (in.)	C (in.)	D (in.)	R (in.)
<b>FOR CIRCULAR PIPE</b>						
24	3	6	72	12	84	3
30	3 1/2	7 1/2	90	12	102	3 1/2
<b>FOR ARCH PIPE</b>						
* 24	3	6	48	12	60	3
* 30	3 1/2	7 1/2	60	12	72	3 1/2
* 36	4 1/2	8 5/8	66	30	96	0
* 42	4 1/2	10	77 1/4	83/4	96	0

**ALTERNATE**

Dia. (in.)	T (in.)	A (in.)	B (in.)	C (in.)	D (in.)	R (in.)
<b>FOR CIRCULAR PIPE</b>						
24	3	9	72	12	84	0
30	3 1/2	11	90	12	102	0
<b>FOR ARCH PIPE</b>						
* 24	3	9	48	12	60	0
* 30	3 1/2	11	60	12	72	0

\* Equivalent Diameter of Circular R.C.P.  
 \*\* Acceptable Flat Bottom Alternate.

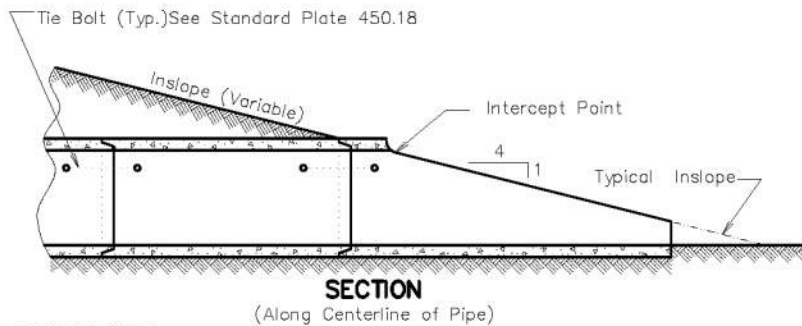

**GENERAL NOTE:**

The length of concrete pipe shown in the construction plans is between sloped ends.

**REINFORCED CONCRETE PIPE SLOPED ENDS-ARCH**  
**NOT TO SCALE**

**CITY OF BOX ELDER**  
**STANDARD DETAIL**  
**CULVERT-RCP SLOPED ENDS-ARCH**

## DETAIL RC010-CULVERT-RCP SLOPED END BAR ASSEMBLY-1

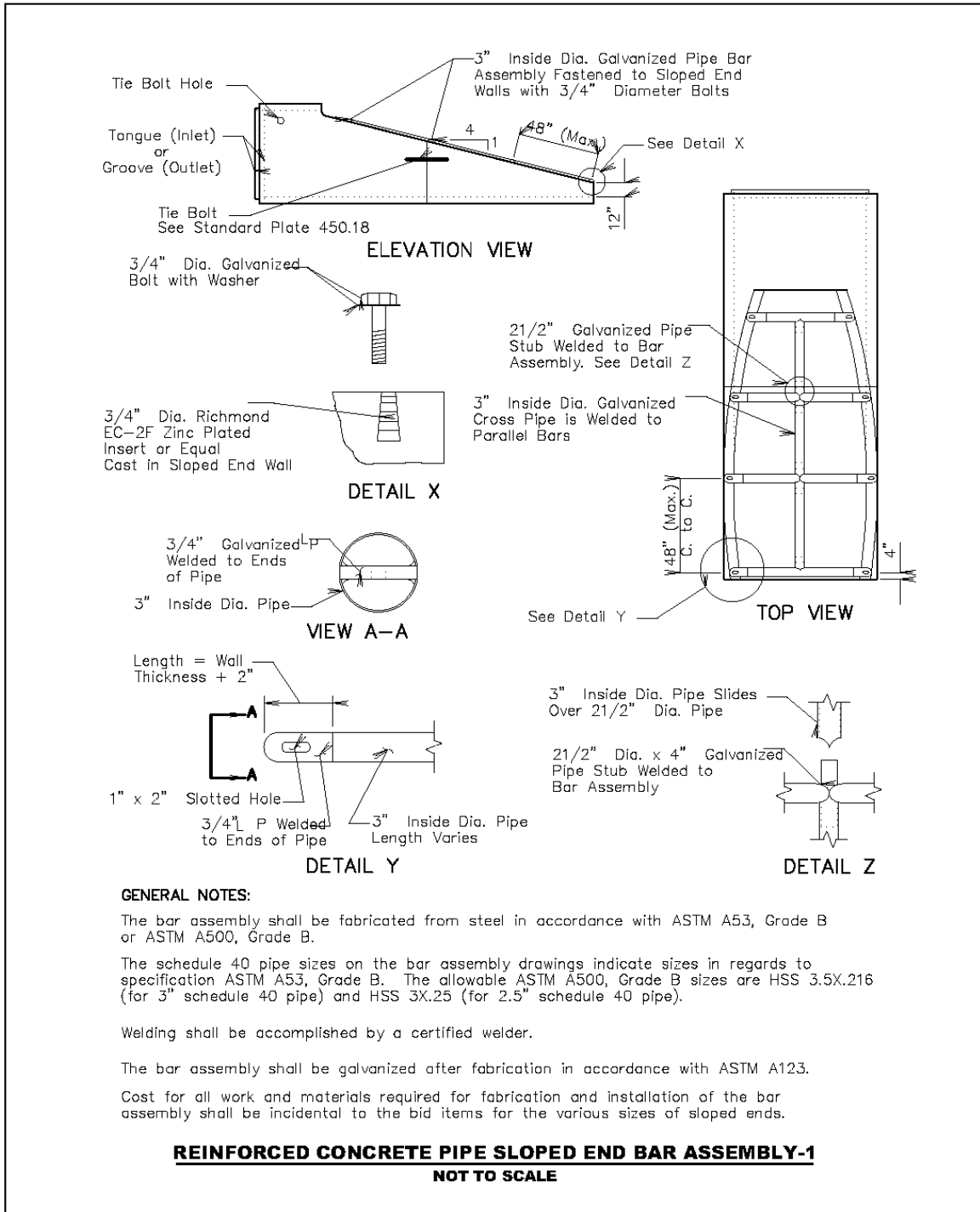

**REINFORCED CONCRETE PIPE SLOPED END BAR ASSEMBLY-1**  
**NOT TO SCALE**

<p><b>CITY OF BOX ELDER</b></p> <p><b>STANDARD DETAIL</b></p> <p><b>CULVERT-RCP SLOPED END BAR ASS.</b></p>	
DETAIL #RC010	REVISED 01/2020



**DETAIL RC011-CULVERT-RCP SLOPED END BAR ASSEMBLY-2**

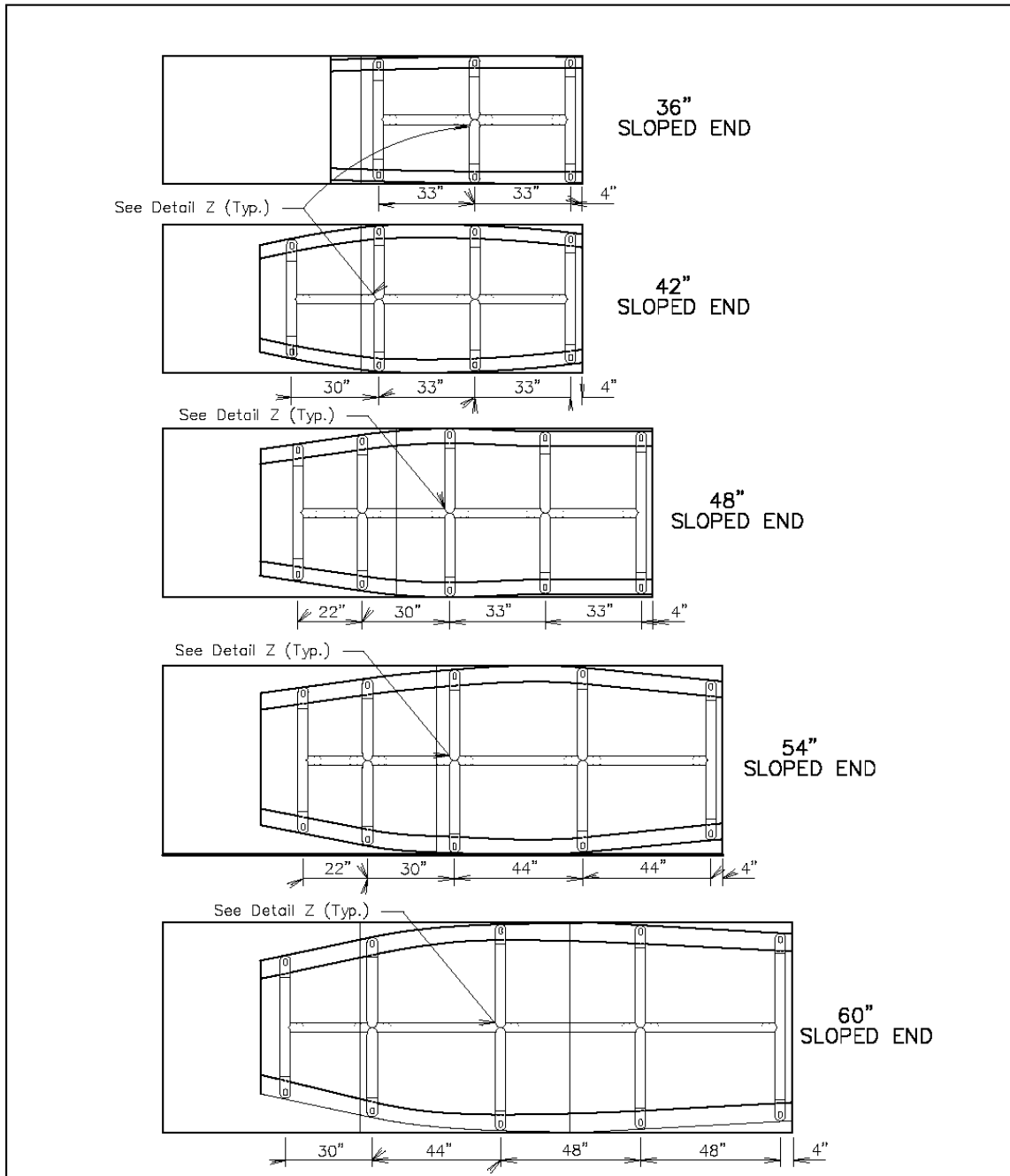

**REINFORCED CONCRETE PIPE SLOPED END BAR ASSEMBLIES-2**  
**NOT TO SCALE**

**CITY OF BOX ELDER**  
**STANDARD DETAIL**  
**CULVERT-RCP SLOPED END BAR ASS.**



DETAIL #RC011

REVISED 01/2020

## DETAIL RC012-CULVERT-RCP SECTIONAL ENDS-ROUND

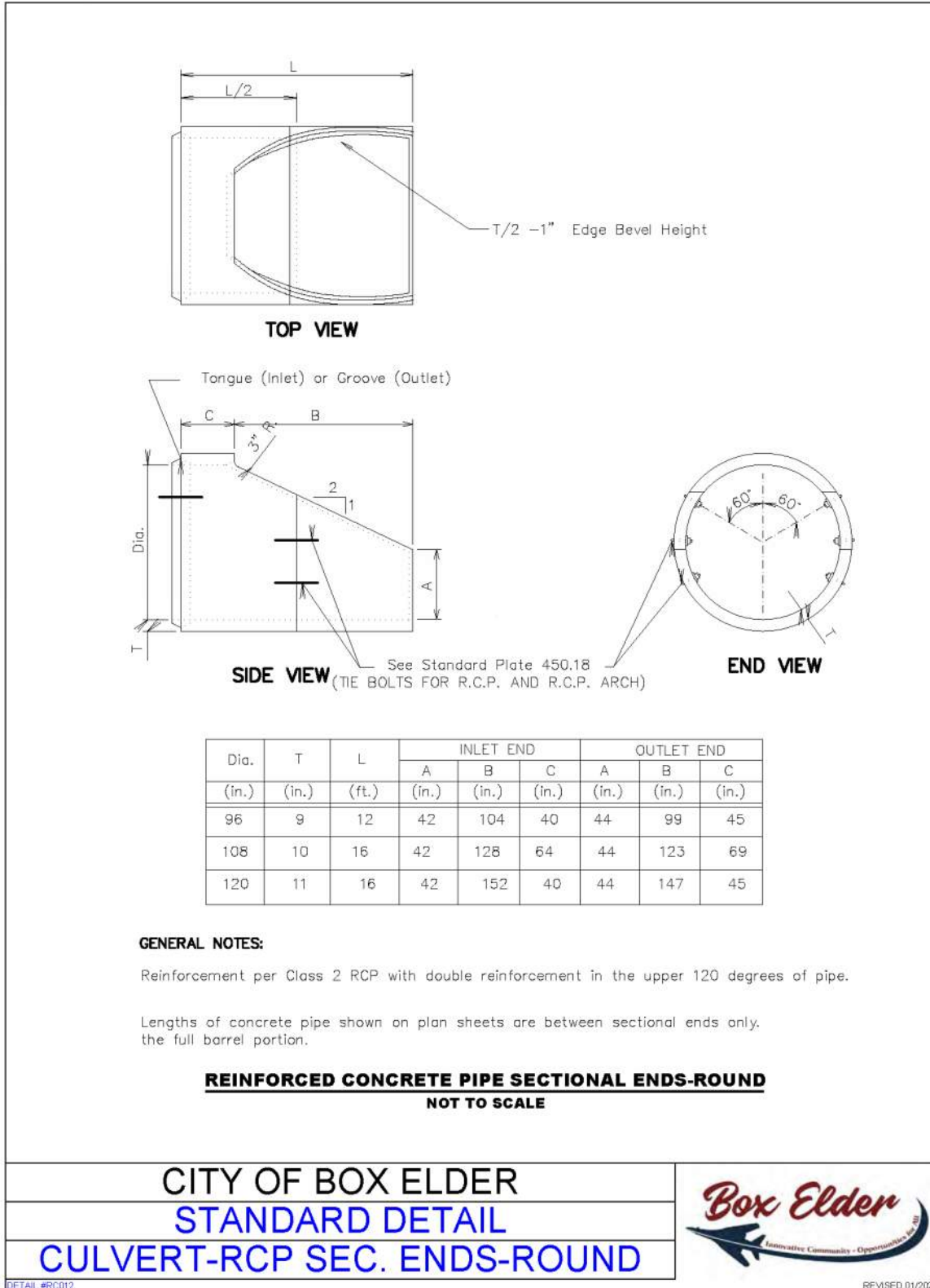

## DETAIL RC013-CULVERT-RCP SECTIONAL ENDS-ARCH

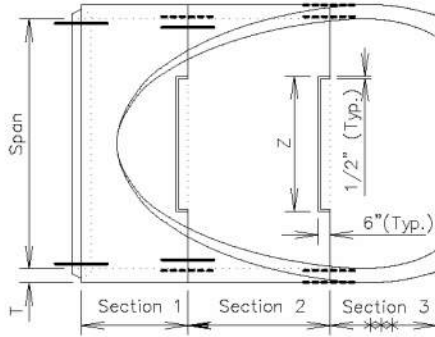

**TOP VIEW**

**GENERAL NOTES:**

Construction of R.C.P. Arch Sectional Ends shall conform to the requirements of Section 990 of the Specifications.

Lengths of concrete pipe shown on plan sheets are between sectional ends only.

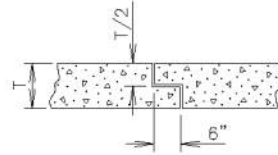

**DETAIL A**

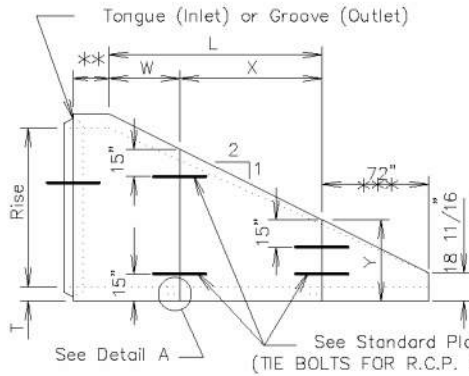

**SIDE VIEW**

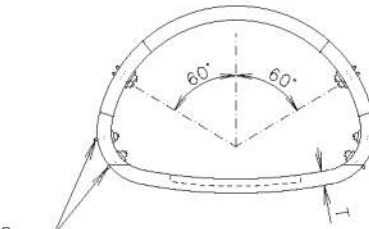

**END VIEW**

* Size (in.)	Approx. Weight Sect. 1 (lbs.)	Approx. Weight Sect. 2 (lbs.)	Approx. Weight Sect. 3 (lbs.)	Rise (in.)	Span (in.)	T (in.)	L (in.)	W (in.)	X (in.)	Y (in.)	Z (in.)
90	19100	3950		72	1151/2	81/2	1021/4	72	301/4	377/8	48
96	22000	6050		78	1223/8	9	1121/2	72	401/2	39	54
108	23000	15800		88	1381/2	10	1291/2	48	811/2	423/8	66
120	27000	24600		967/8	154	11	144	48	96	467/8	78
132	27950	25260	13640	1061/2	1683/4	10	144	48	96		90

\*Equivalent Diameter of Circular R. C. P.  
 \*\*2'-0" for Groove End and 2'-7" for Tongue End.  
 \*\*\*Section 3 available for 132" size only.

**REINFORCED CONCRETE PIPE SECTIONAL ENDS-ARCH**  
 NOT TO SCALE

**CITY OF BOX ELDER**  
**STANDARD DETAIL**  
**CULVERT-RCP SEC. ENDS-ARCH**



DETAIL #RC013

REVISED 01/2020

## DETAIL RC014-CULVERT-RCP TIE BOLTS

Wgll "t" (in.)	Rod Dia. (in.)	Pipe Sleeve Dia. (nominal)
< 31/4	5/8	3/4
31/2-61/2	3/4	1
≥ 7	1	1 1/4

**GENERAL NOTES:**

Tie bolts shall conform to ASTM F1554 Grade 36 or ASTM A36. Nuts shall be heavy hex conforming to ASTM A563. Washers shall conform to ASTM F436.

Pipe Sleeve shall conform to ASTM A500 or A53, Grade B.

Galvanize adjustable eye bolt tie assembly in accordance with ASTM A153.

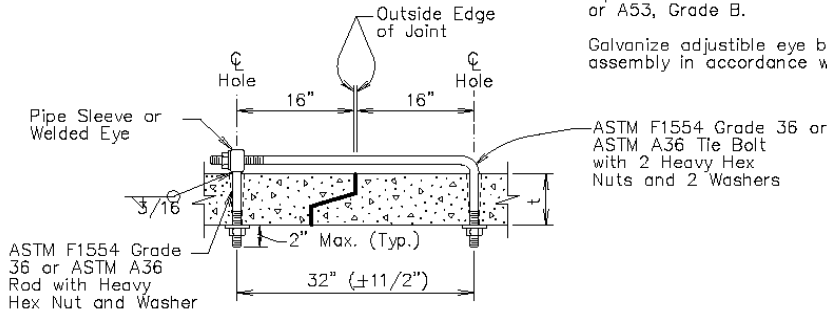

**ADJUSTABLE EYE BOLT TIE**

Pipe Dia. (in.)	"L" (in.)	Bolt Dia. (in.)
< 48	4	3/4
> 48	6	1

**GENERAL NOTES:**

Angles shall conform to ASTM A36.

Bolts shall conform to ASTM A307. Nuts shall be heavy hex conforming to ASTM A563. Washers shall conform to ASTM F436.

Galvanize angles, bolts, nuts, and washers in accordance with ASTM A153.

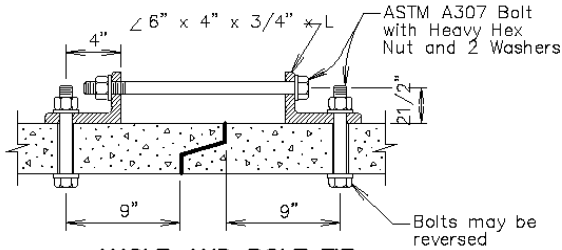

**ANGLE AND BOLT TIE**

**GENERAL NOTES:**

In lieu of the tie bolts detailed above other types of tie bolt connections may be installed as approved by the Office of Bridge Design.

All pipe sections of R.C.P. and R.C.P. Arch shall be tied with tie bolts except for pipe located between drop inlets, manholes, and junction boxes. All pipe sections of pipes that only enter or exit drop inlets, manhole, and junction boxes shall be tied with tie bolts.

There will be no separate measurement or payment for the tie bolts. The cost for furnishing and installing the tie bolts shall be incidental to the contract unit price per foot for the corresponding bid item for R.C.P. or R.C.P. Arch.

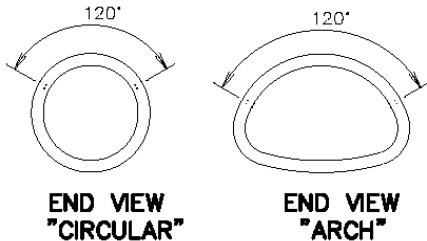

**REINFORCED CONCRETE PIPE TIE BOLTS**

NOT TO SCALE

<b>CITY OF BOX ELDER</b>
<b>STANDARD DETAIL</b>
<b>CULVERT-RCP TIE BOLTS</b>



DETAIL #RC014

REVISED 01/2020

## DETAIL RC020-CULVERT-CMP-ARCH

* Dia. (in.)	2 $\frac{2}{3}$ " x 1 $\frac{1}{2}$ " CORRUGATIONS			3" X 1" CORRUGATIONS		
	S Span (in.)	H Rise (in.)	Area (Sq. Ft.)	S Span (in.)	H Rise (in.)	Area (Sq. Ft.)
15	17	13	1.1			
18	21	15	1.6			
21	24	18	2.2			
24	28	20	2.8			
30	35	24	4.4			
36	42	29	6.4	40	31	7.0
42	49	33	8.7	46	36	9.4
48	57	38	11.4	53	41	12.3
54	64	43	14.3	60	46	15.6
60	71	47	17.6	66	51	19.3
66	77	52	21.3	73	55	23.2
72	83	57	25.3	81	59	27.4
78				87	63	32.1
84				95	67	37.0
90				103	71	42.4
96				112	75	48.0
102				117	79	54.2
108				128	83	60.8
114				137	87	67.4
120				142	91	74.5

\* Equivalent diameter of circular C.M.P.

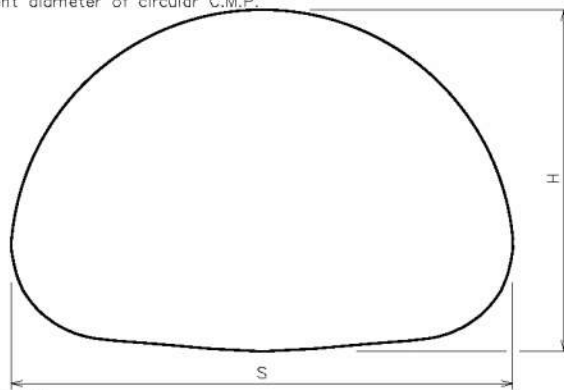

**GENERAL NOTE:**

All dimensions measured from inside crest.

**CORRUGATED METAL PIPE ARCH CULVERT**  
**NOT TO SCALE**

**CITY OF BOX ELDER**  
**STANDARD DETAIL**  
**CULVERT-CMP-ARCH**



DETAIL #RC020

REVISED 01/2020

**DETAIL RC021-CULVERT-CMP SLOTTED DRAIN-1**

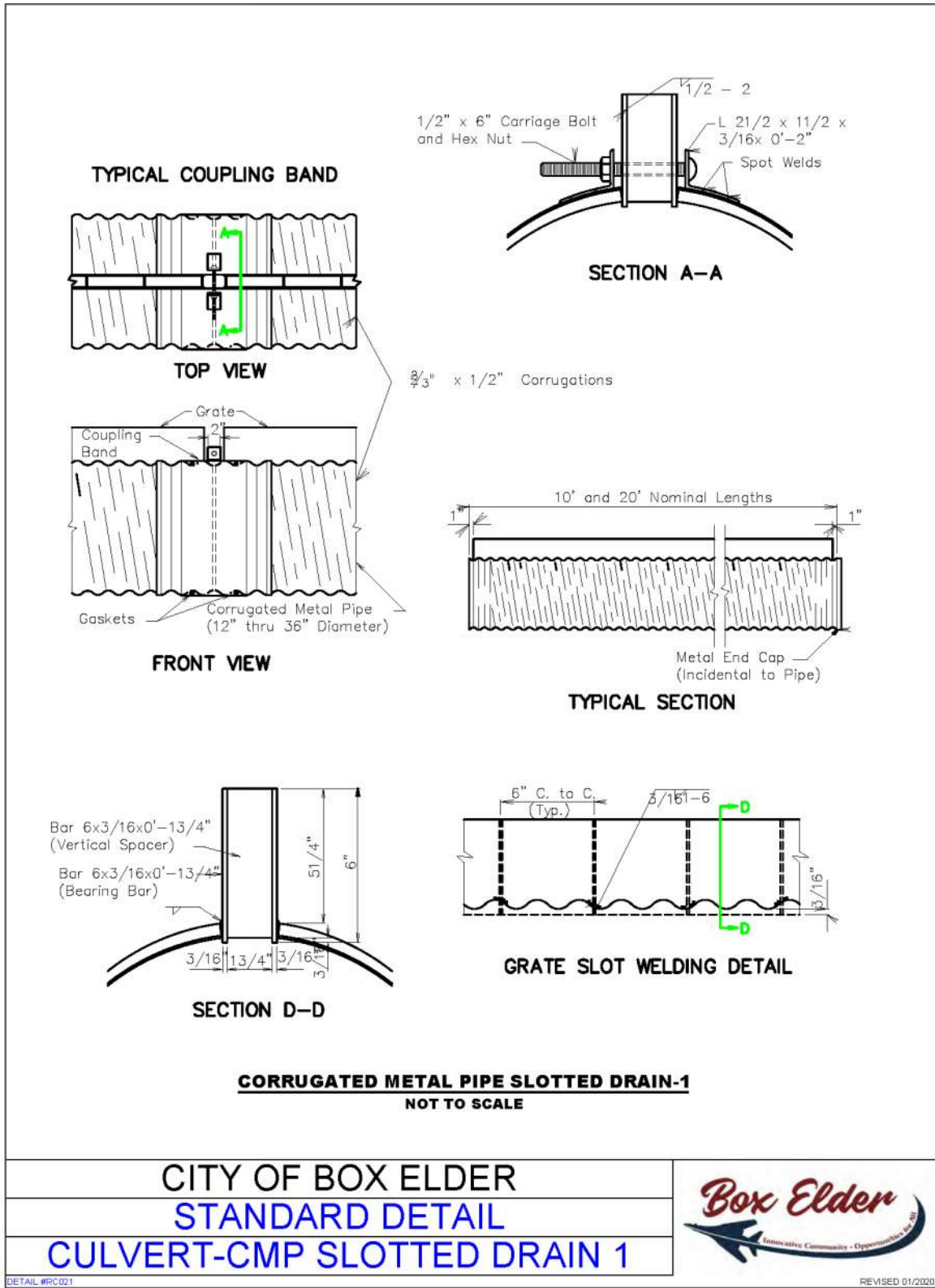

## DETAIL RC022-CULVERT-CMP SLOTTED DRAIN-2

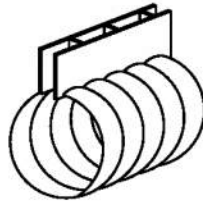

**SLOTTED C.M.P. DRAIN**

### **GENERAL NOTES:**

A typical length of Slotted Drain is twenty (20) feet. Installation should be in multiples of ten (10) feet unless situations dictate otherwise.

All Slotted Drain materials and hardware shall be galvanized.

Metal end caps shall be provided for the closed end of each installation. The end caps shall be the same gage as the pipe.

All joints and end caps shall be watertight.

Close riveted soldered annular or continuously welded helical pipe shall be used and shall be watertight.

Units on which the spelter coating has been burned by welding or otherwise damaged in fabrication or during installation shall be regalvanized or painted with one full brush coat of zinc-rich paint conforming to Military Specification Mil-P-21035 or with at zinc-dust, zinc-oxide paint conforming to Federal Specification TT-P-641-B, Type III. Prior to painting, the surface shall be properly cleaned and approved.

Two gaskets will be required for each coupling band or joint and shall be rendered watertight by methods approved by the Engineer.

The slot shall be covered with an acceptable material during paving operations and/or installation of curb and gutter.

Anchors shall be " Dia. x 3" galvanized bolts and nuts. The nuts shall be welded to the slot at two (2) foot spacing. Bolts shall be added just prior to installation to avoid damage.

A trapezoidal design for spacer bars, either vertical or slanted, may be an alternate for the vertical bars shown on the details. The Slotted Drain with slanted spacer bars shall be installed with the slanted spacer bars oriented toward the flow.

A Heel Guard (1/2 inch #13 expanded metal mesh) shall be furnished when called for in the plans and shall be welded to the grating before delivery to the project.

Slotted Drain will be measured along the centerline of the pipe. The length shall be the overall installed length from end to end including any coupling bands that may be between sections. The outlet pipe will be paid for as CMP and End Sections.

Slotted Drain will be paid for at the contract unit price per Foot of Slotted C.M.P. Payment will be full compensation for materials, labor, equipment, and incidentals required.

### **CORRUGATED METAL PIPE SLOTTED DRAIN-2**

**NOT TO SCALE**

**CITY OF BOX ELDER**  
**STANDARD DETAIL**  
**CULVERT-CMP SLOTTED DRAIN 2**



DETAIL #RC022

REVISED 01/2020

## DETAIL RC023-CULVERT-CMP ELBOWS

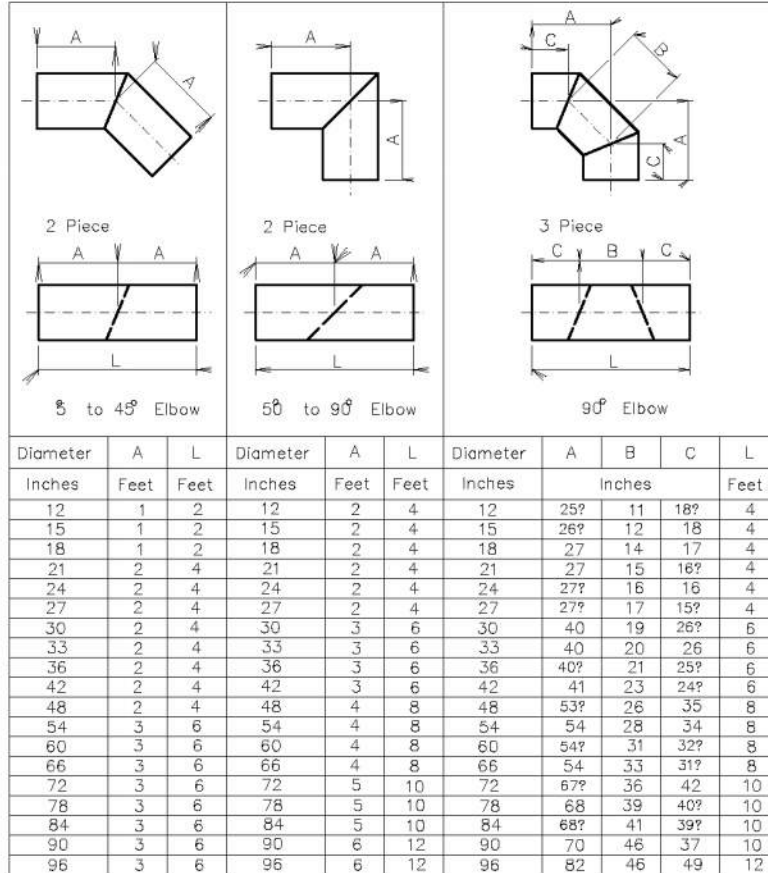

### FABRICATED ELBOW LENGTHS FOR ALL CORRUGATIONS

**GENERAL NOTES:**

All dimensions shown are nominal.

L = Linear Feet of C.M.P. required to fabricate fitting.

### **CORRUGATED METAL PIPE FABRICATED LENGTHS FOR ELBOWS** **NOT TO SCALE**

**CITY OF BOX ELDER**  
**STANDARD DETAIL**  
**CULVERT-CMP ELBOWS**



DETAIL #RC023

REVISED 01/2020



## DETAIL RC024-CULVERT-CMP FLARED ENDS-ROUND

Alternate Type Connector Sections may be used with approval of the Engineer.

**PLAN**

**ELEVATION**

1" O.D. 14 Ga. Galv. Tubing  
Sheet

**TUBING ATTACHMENT DETAILS SECTION A-A**

... x " Gal. Buttonhead Rivets spaced 6" C. to C. Overall length of rivets=0.78"

**TYPICAL CROSS-SECTION**

**GENERAL NOTES:**

All 3 pc. bodies shall have 12 Ga. sides and 10 Ga. center panels. Width of center panels shall be greater than 20% of the pipe periphery. Multiple panel bodies to have lap seams tightly joined by ... Dia. galvanized rivets or bolts.

For 60" through 84" sizes, reinforced edges shall be supplemented with galvanized stiffener angles. The angles will be 2" x 2" x , for 60" through 72" diameters and 2" x 2" x , for 78" and 84" diameters. The angles shall be attached by ... diameter galvanized nuts and bolts.

Rivets and Bolts shall be ... Dia. Min. for 10 Ga. and 12 Ga. sheet, and 5" Dia. Min. for 14 Ga. and 16 Ga. sheets. Tighten nuts with torque wrench to 25 lbs. torque.

Dia. D (in.)	Ga.	DIMENSIONS (in.)					Approx. Slope	Body
		A	B	H	L	W		
12	16	6	6	6	21	24	2?:1	1 Pc.
15	16	7	8	6	26	30	2?:1	1 Pc.
18	16	8	10	6	31	36	2?:1	1 Pc.
21	16	9	12	6	36	42	2?:1	1 Pc.
24	16	10	13	6	41	48	2?:1	1 Pc.
30	14	12	16	8	46	60	2?:1	1 Pc.
36	14	14	19	9	51	72	2?:1	2 Pc.
42	12	16	22	11	60	84	2?:1	2 Pc.
48	12	18	27	12	69	90	2?:1	2 Pc.
54	12	18	30	12	78	102	2:1	3 Pc.
60	12	18	33	12	84	114	1?:1	3 Pc.
66	12	18	36	12	87	120	1?:1	3 Pc.
72	12	18	39	12	87	126	1 1/3:1	3 Pc.
78	12	18	42	12	87	132	1?:1	3 Pc.
84	12	18	45	12	87	138	1 1/6:1	3 Pc.

**STANDARD CONNECTIONS**

Threaded 1/2" Dia. Rod over Top of culvert  
Pipe  
Bolted on Side Lug  
For 30" through 84"

Dimple Band Collar bolted to end section with ... bolts  
Alternate for all sizes

Pipe  
Strap Bolt  
Flat Strap Connector  
For 12" through 24" only

NOTE:  
Tubing is slipped over the sheet and rivets or lugs prior to forming operations of the apron.

**SECTION A-A (alternate)**

**SECTION A-A (alternate)**

**CORRUGATED METAL PIPE FLARED ENDS-ROUND**

**NOT TO SCALE**

**CITY OF BOX ELDER**

**STANDARD DETAIL**

**CULVERT-CMP FLARED ENDS-ROUND**

DETAIL #RC024
REVISED 01/2020

## DETAIL RC025-CULVERT-CMP FLARED ENDS-ARCH

Alternate Type Connector Sections may be used with approval of the Engineer.

**PLAN**

**ELEVATION**

**TUBING ATTACHMENT DETAILS SECTION A-A**

**TYPICAL CROSS-SECTION**

Span x Rise (in.)x(in.)	Equiv. Dia. (in.)	Ga.	APPROX. DIMENSIONS (in.)					Approx. Slope	Body
			A	B	H	L	W		
17x13	15	16	7	9	6	19	30	2?:1	1 Pc.
21x15	18	16	7	10	6	23	36	2?:1	1 Pc.
24x18	21	16	8	12	6	28	42	2?:1	1 Pc.
28x20	24	16	9	14	6	32	48	2?:1	1 Pc.
35x24	30	14	10	16	6	39	60	2?:1	1 Pc.
42x29	36	14	12	18	8	46	75	2?:1	1 Pc.
49x33	42	12	13	21	9	53	85	2?:1	2 Pc.
57x38	48	12	16	26	12	63	90	2?:1	2 Pc.
64x43	54	12	18	30	12	70	102	2?:1	2 Pc.
71x47	60	12	18	33	12	77	114	2?:1	3 Pc.
77x52	66	12	18	36	12	77	126	2:1	3 Pc.
83x57	72	12	18	39	12	77	133	2:1	3 Pc.

**STANDARD CONNECTIONS**

For 17"x13" through 83"x57"      Alternate for all sizes

① For 17" through 28" span pipe-arches a flat strap connector may be used in place of the rod connection. Strap connector shall be 1" wide, 12 ga. strap with standard 6" long x " dia. band bolt and nut.

**NOTE:**  
Tubing is slipped over the sheet and rivets or lugs prior to forming operations of the apron.

**SECTION A-A (alternate)**

**SECTION A-A (alternate)**

**CORRUGATED METAL PIPE FLARED ENDS-ARCH**

NOT TO SCALE

**CITY OF BOX ELDER**

**STANDARD DETAIL**

**CULVERT-CMP FLARED ENDS-ARCH**

DETAIL RC025
REVISED 01/2020

## DETAIL RC026-CULVERT-CMP SLOPED ENDS-1

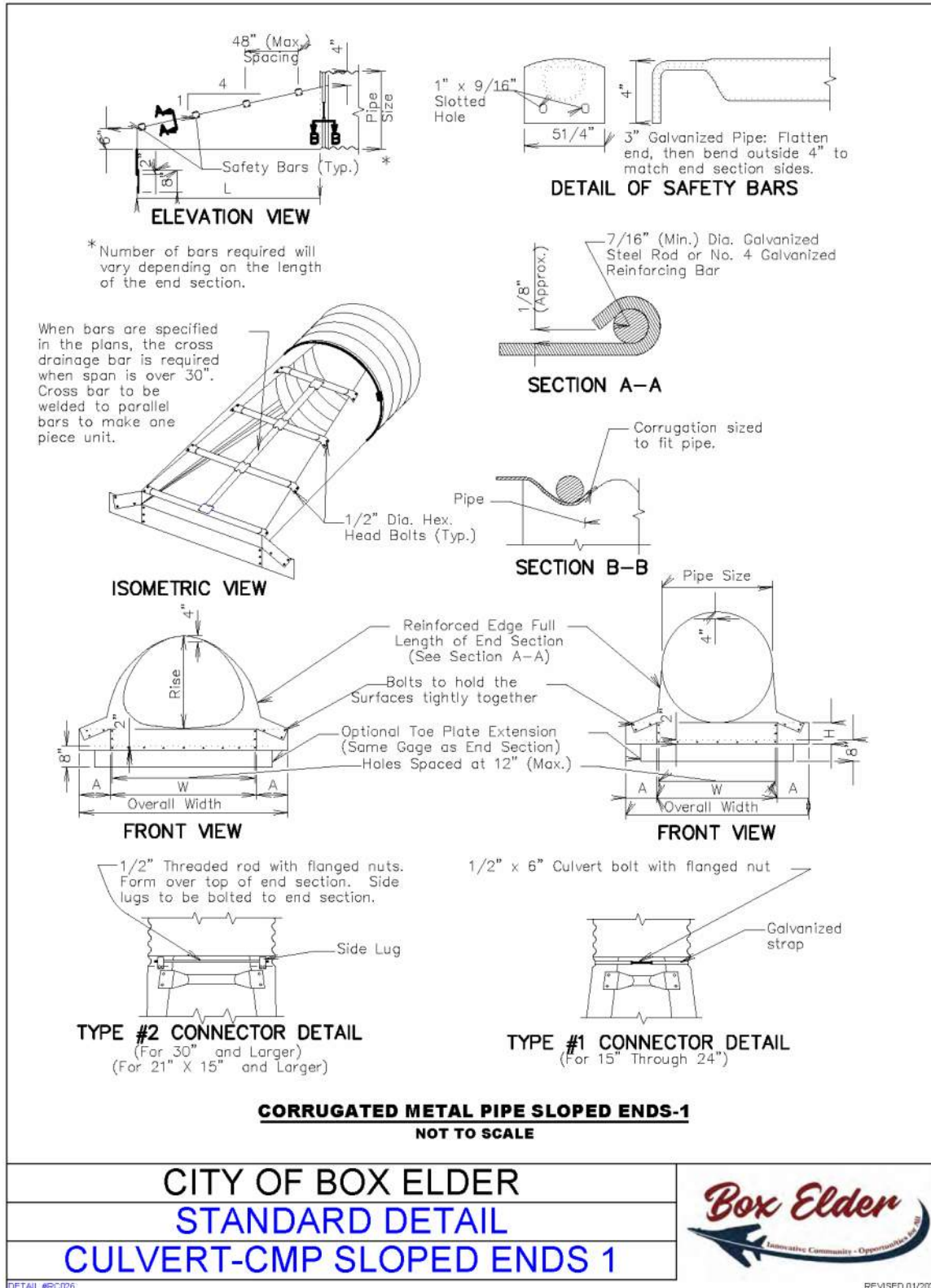

## DETAIL RC027-CULVERT-CMP SLOPED ENDS-2

ARCH C.M.P. SLOPED ENDS										
Equiv. Dia. (Inch)	(Inches)		Min. Thick.		Dimensions (Inches)				L Dimensions	
	Span	Rise	Inch	Gage	A	H	W	Overall Width	Slope	Length (Inch)
18	21	15	.064	16	8	6	27	43	4:1	20
21	24	18	.064	16	8	6	30	46	4:1	32
24	28	20	.064	16	8	6	34	50	4:1	40
30	35	24	.079	14	12	9	41	65	4:1	56
36	42	29	.109	12	12	9	48	72	4:1	76
42	49	33	.109	12	16	12	55	87	4:1	92
48	57	38	.109	12	16	12	63	95	4:1	112
54	64	43	.109	12	16	12	70	102	4:1	132
60	71	47	.109	12	16	12	77	109	4:1	148
72	83	57	.109	12	16	12	89	121	4:1	188

CIRCULAR C.M.P. SLOPED ENDS								
Pipe Dia. (Inch)	Min. Thick.		Dimensions (Inches)				L Dimensions	
	Inch	Gage	A	H	W	Overall Width	Slope	Length (Inch)
15	.064	16	8	6	21	37	4:1	20
18	.064	16	8	6	24	40	4:1	32
21	.064	16	8	6	27	43	4:1	44
24	.064	16	8	6	30	46	4:1	56
30	.109	12	12	9	36	60	4:1	80
36	.109	12	12	9	42	66	4:1	104
42	.109	12	16	12	48	80	4:1	128
48	.109	12	16	12	54	86	4:1	152
54	.109	12	16	12	60	92	4:1	176
60	.109	12	16	12	66	98	4:1	200

**GENERAL NOTES:**

Safety bars shall be attached to sloped ends over 30" in diameter only when specified in the plans.

Sloped ends shall be fabricated from galvanized steel and shall conform to the requirements of the Specifications.

Safety bars shall be fabricated from steel schedule 40 pipe in conformance with ASTM A53, grade B or HSS 3.5X.216 in conformance with ASTM A500, grade B.

Slotted holes for safety bar attachment shall be provided for all end sections.

Attachment to circular pipes 15" through 24" diameter shall be made with Type #1 straps. All other sizes shall be attached with Type #2 rods and lugs.

When stated in the plans, optional toe plate extension shall be punched and bolted to end section apron lip with 3/8" diameter galvanized bolts. Steel for toe plate extension shall be same gauge as end section. Dimensions shall be overall width less 6" by 8" high.

Cost of all work and materials required for fabrication and installation of sloped ends shall be incidental to the bid items for the various sizes of sloped ends.

**CORRUGATED METAL PIPE SLOPED ENDS-2**  
**NOT TO SCALE**

**CITY OF BOX ELDER**  
**STANDARD DETAIL**  
**CULVERT-CMP SLOPED ENDS 2**



DETAIL #RC027

REVISED 01/2020

**DETAIL RC028-CULVERT-CMP-RCP TRANSITIONS**

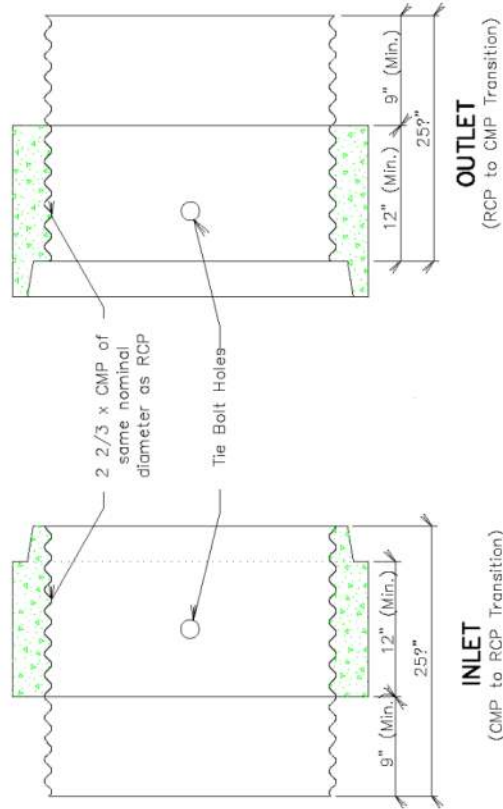

**GENERAL NOTE:**

Arch pipe transitions shall be fabricated similar to the round transition shown above.

**CORRUGATED METAL PIPE (CMP) TO REINFORCED CONCRETE PIPE (RCP)  
AND RCP TO CMP TRANSITIONS**  
**NOT TO SCALE**

**CITY OF BOX ELDER**  
**STANDARD DETAIL**  
**CULVERT-CMP/RCP TRANSITIONS**



DETAIL #RC028

REVISED 01/2020

**DETAIL RC029-CULVERT-CMP SMOOTH TAPERED SLEEVE**

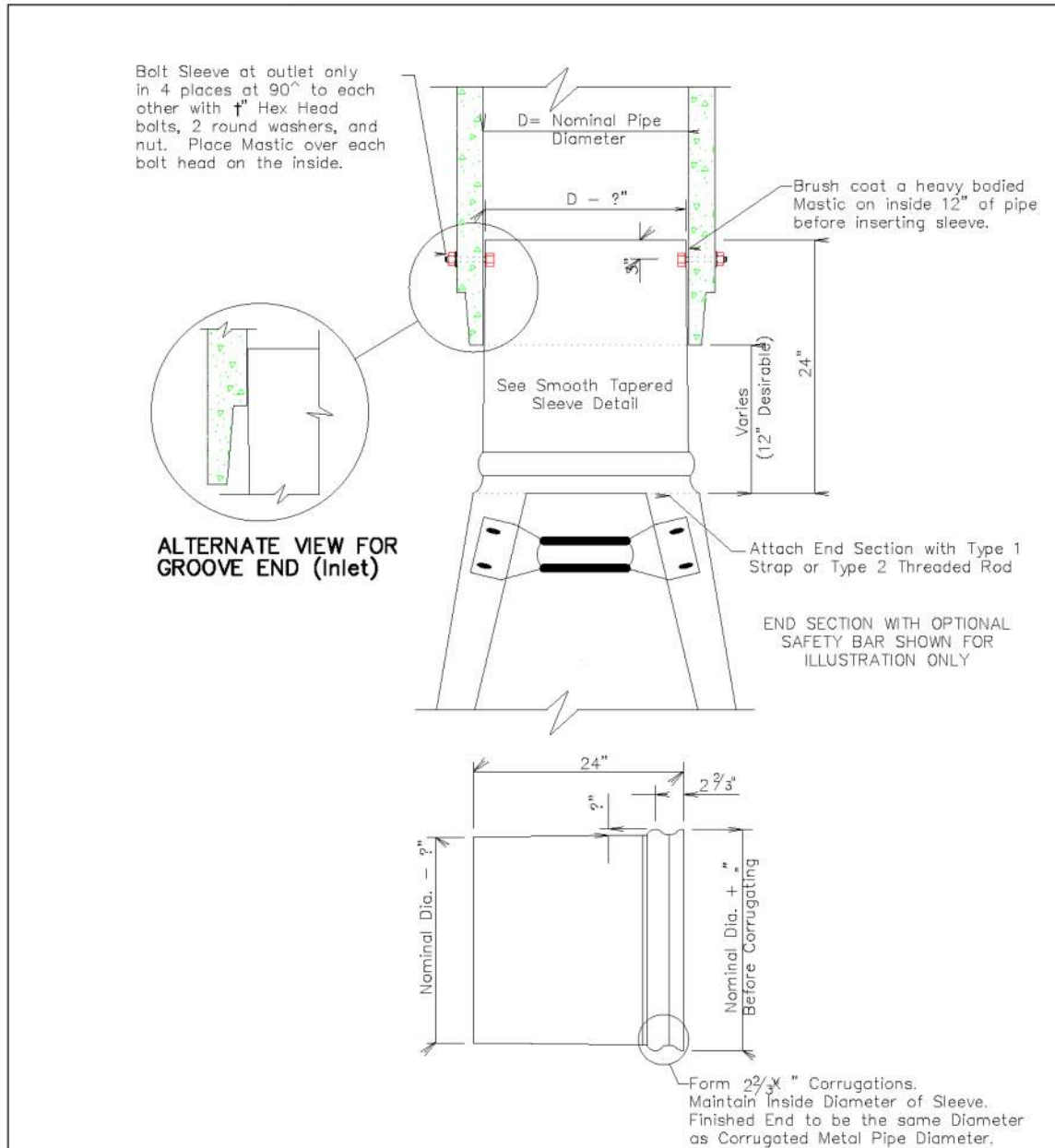

**SMOOTH TAPERED SLEEVE DETAIL**

**GENERAL NOTE:**

Metal shall be 12 gauge smooth Galvanized in accordance with AASHTO M218.

**CORRUGATED METAL PIPE SMOOTH TAPERED SLEEVE**

**NOT TO SCALE**

**CITY OF BOX ELDER**  
**STANDARD DETAIL**  
**CULVERT-CMP SMOOTH TAPERED SL.**



DETAIL #RC029

REVISED 01/2020

## DETAIL RC040-CULVERT-PRECAST BOX BARREL TIE

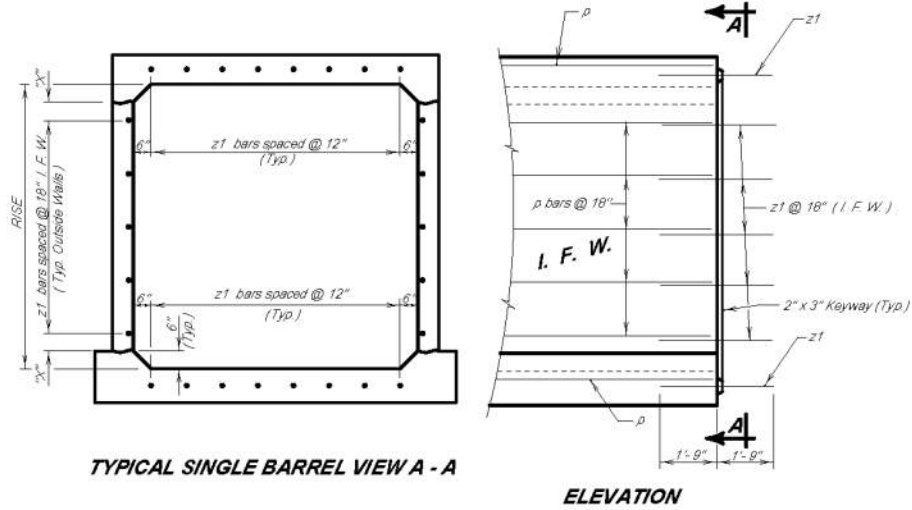

**LEGEND FOR PLACING RE-STEEL**  
I. F. W. - Inside Face Wall

RISE	"X"
3'-0"	3"
4'-0"	9"
5'-0"	6"
6'-0"	3"
7'-0"	9"
8'-0"	6"
9'-0"	3"
10'-0"	9"
11'-0"	6"
12'-0"	3"

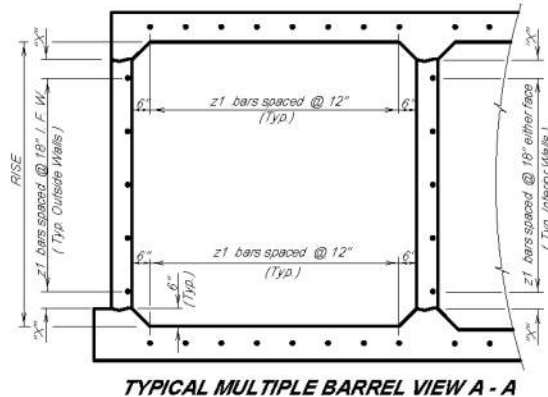

**GENERAL NOTES:**

- z1 bars shall be placed in the middle of the 2" x 3" keyway in the top and bottom slabs. z1 bars shall be lapped with the longitudinal p bars in the inside face of the wall for outside walls and in either face for interior walls. z1 bars are listed and included elsewhere in plans.
- Drainage Fabric Protection shall be placed in accordance with Section 422, or Section 560, whichever is applicable.

**CULVERT-PRECAST BOX BARREL TIE REINFORCEMENT**  
NOT TO SCALE

CITY OF BOX ELDER  
STANDARD DETAIL  
CULVERT-PRECAST BOX BARREL TIE



DETAIL #RC040

REVISED 01/2020

## DETAIL RC041-CULVERT-PRECAST BOX TIE BOLT ASSEMBLY

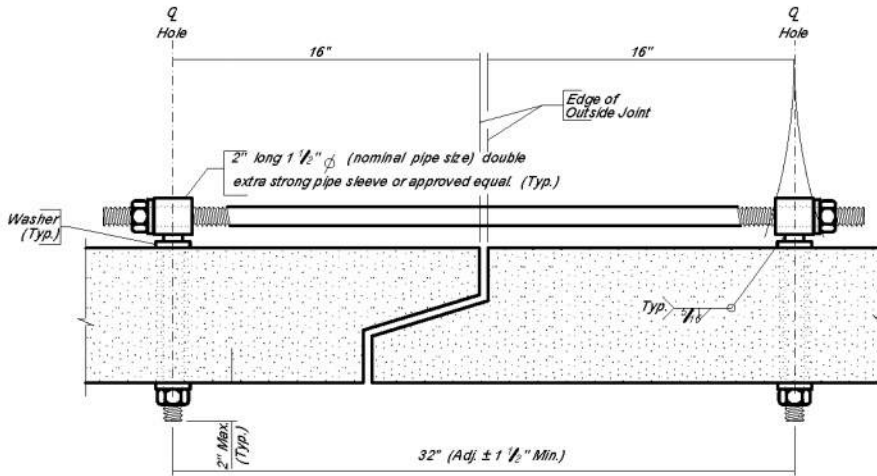

**TIE BOLT ASSEMBLY**

**GENERAL NOTES:**

1. All holes for tie bolts shall be cast-in-place 16 inches from outside edge of joint. Cast in inserts or sleeves, if used, shall be made of a corrosion resistant material.
2. Ties shall be 1 inch  $\phi$  and conform to the requirements of ASTM A36, ASTM A307, or ASTM F155-4, Gr. 36. Nuts shall be heavy hex in conformance with ASTM A563. Washers shall conform to ASTM F436, Type 1. The welded pipe sleeve shall conform to ASTM A53, Grade B.
3. Welding and weld inspection shall be in conformance with AWS/AISI D1.1 - (Current Year) Structural Welding Code - Steel.
4. Tie Bolt Assembly shall be galvanized in accordance with ASTM A153 or ASTM F2329 as applicable.
5. Tie Bolt Assembly details may vary from that shown, but alternate tie bolt assemblies are subject to testing to demonstrate equal strength. Submit details, through proper channels, to the Office of Bridge Design for approval.
6. All costs for furnishing and in stalling the precast box culvert tie bolt assembly shall be incidental to the contract unit price per Foot for "Precast Concrete Box Culvert, Furnish".

**PRECAST BOX CULVERT TIE BOLT ASSEMBLY  
NOT TO SCALE**

CITY OF BOX ELDER  
STANDARD DETAIL  
CULVERT-PRECAST BOX TIE BOLT AS.



DETAIL #RC041

REVISED 01/2020



# DETAIL RC042-CULVERT-PRECAST BOX SLOPED END SECTION

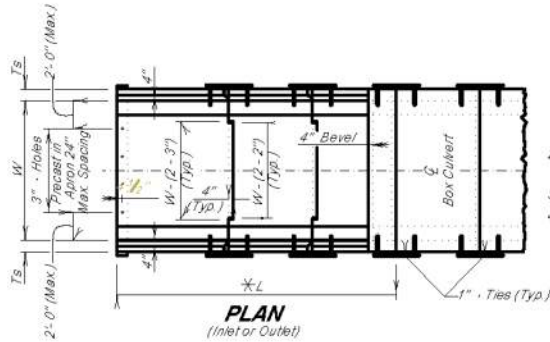

### CUTOFF WALL

1. All costs associated with furnishing and installing the Cutoff Wall, whether precast or cast-in-place, shall be incidental to the contract unit price per each for "Precast Box Culvert End Section, Furnish".
2. Concrete for cast-in-place cutoff wall shall be Class M6 concrete in accordance with Section 462 of the Specifications.
3. All reinforcing steel shall conform to ASTM A615 Grade 60.
4. Alternate details will be allowed, subject to the approval of the Bridge Construction Engineer.

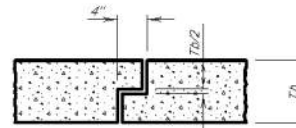
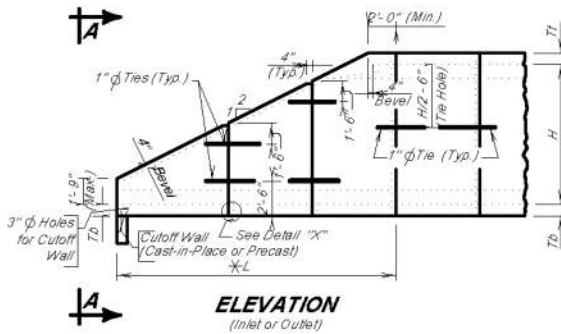

### DETAIL "X"

NOTE: Joint details may vary from that shown, according to the manufacturer's design. Submit details with shop plans for approval.

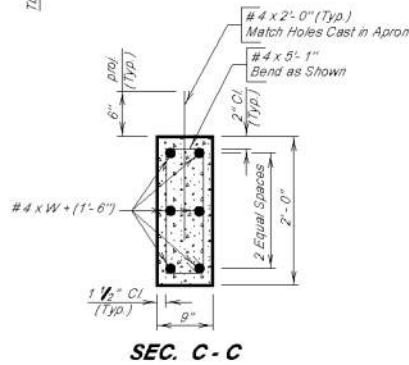
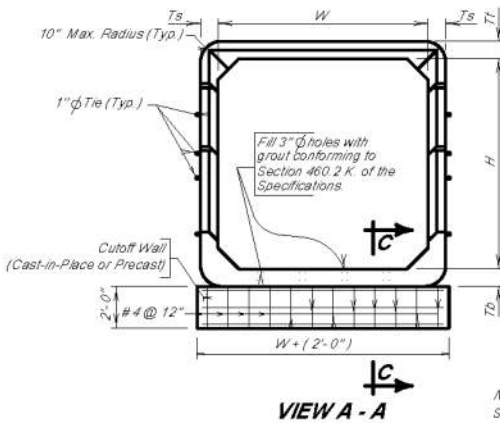

### LEGEND

W = Width of Opening  
 H = Height of Opening  
 Tt = Thickness of Top Slab  
 Tb = Thickness of Bottom Slab  
 Ts = Thickness of Side Wall  
 L = Length of End Section

NOTES:  
 See GENERAL DRAWING for W and H dimensions.  
 Tt, Tb, L, and Ts dimensions shall be furnished by the Contractor.  
 \* Length and number of units may vary from that shown.

**PRECAST BOX CULVERT WITH SLOPED END SECTION**  
 NOT TO SCALE

CITY OF BOX ELDER  
 STANDARD DETAIL  
 CULVERT-PRECAST BOX-SLOPED END



DETAIL #RC042

REVISED 01/2020

# DETAIL RC045-CULVERT-PRECAST DOUBLE BOX WITH SLOPED END-2' CUTOFF WALL

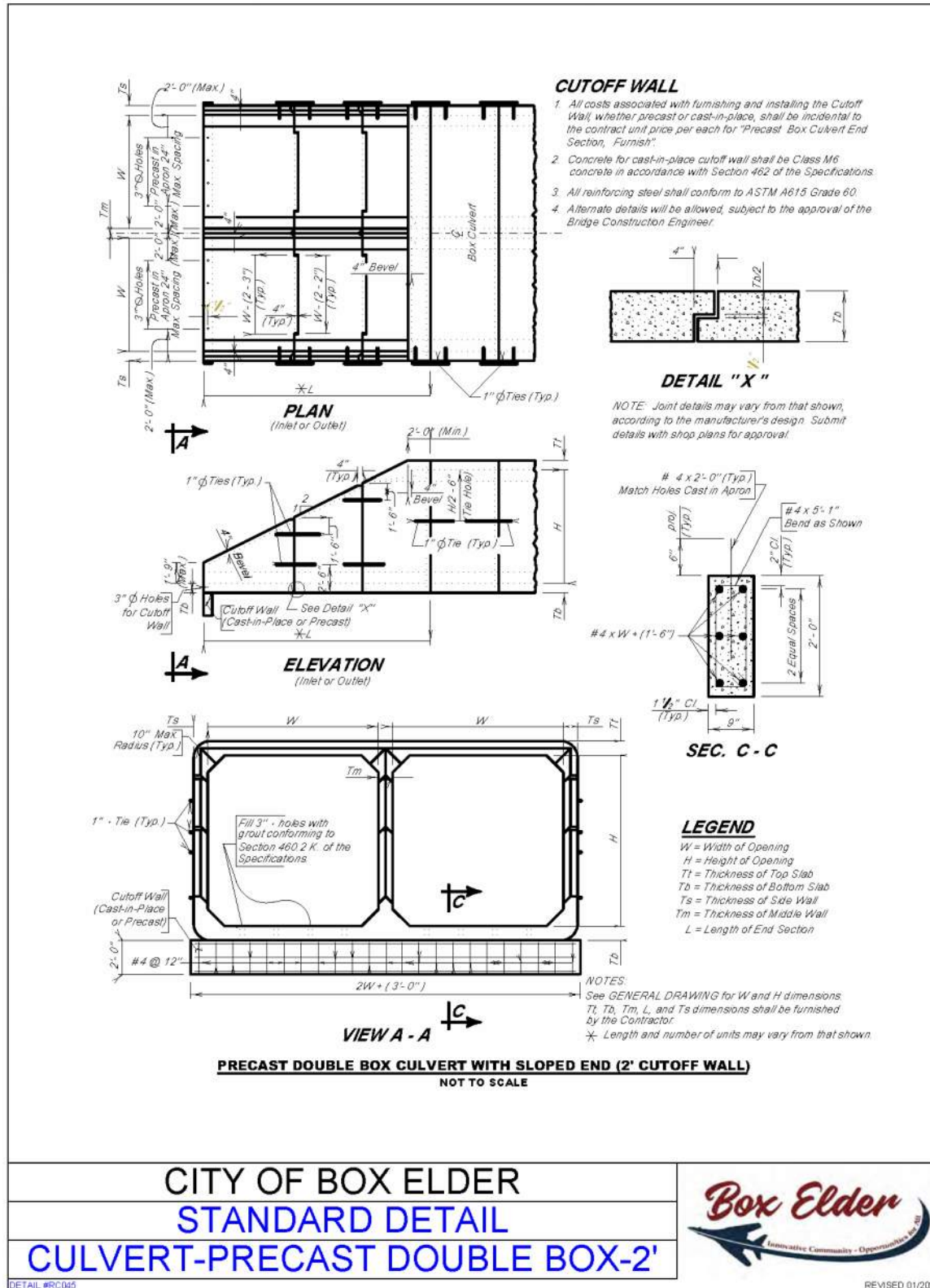

# DETAIL RC046-CULVERT-PRECAST DOUBLE BOX WITH SLOPED END-4' CUTOFF WALL

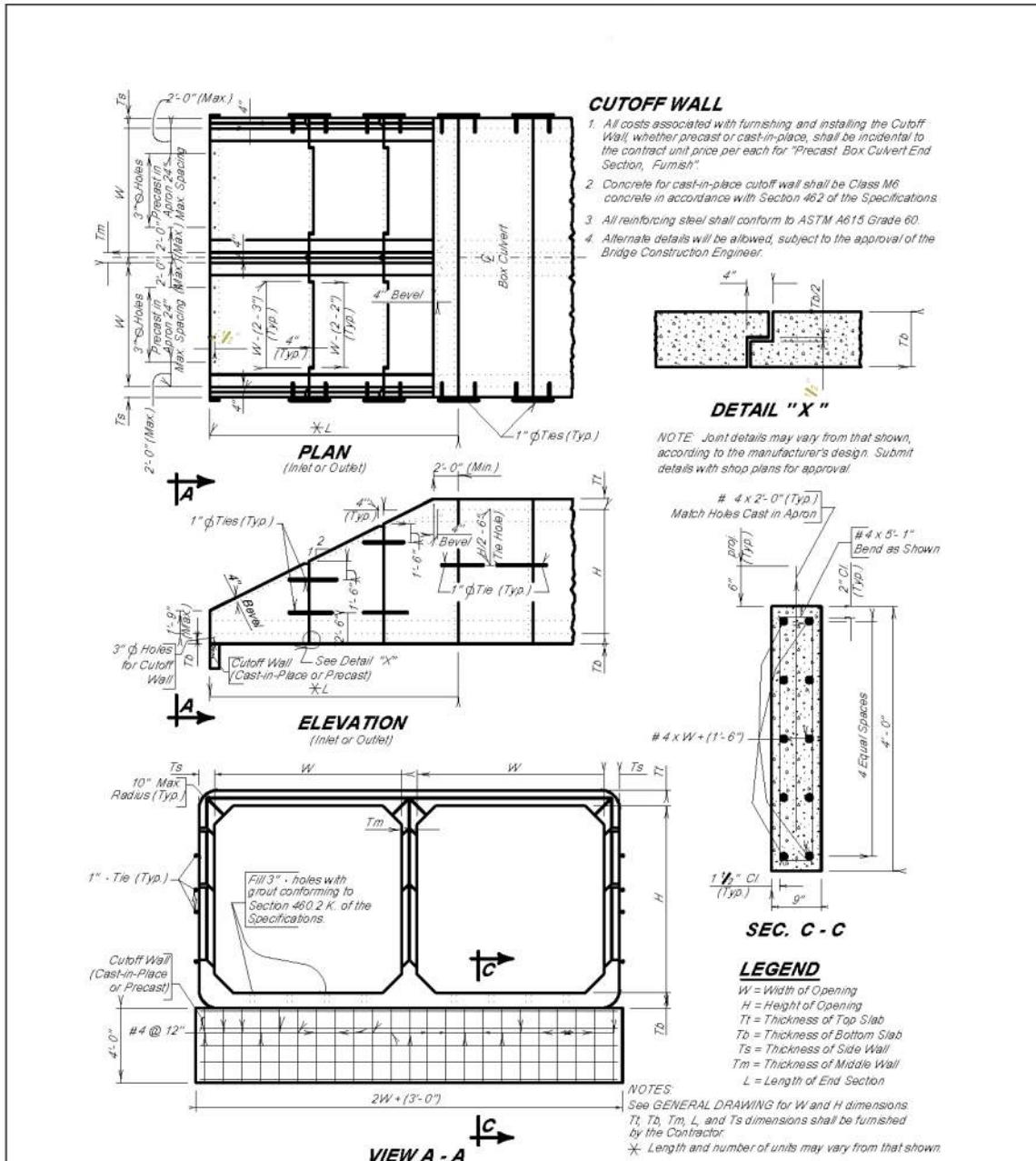

**PRECAST DOUBLE BOX CULVERT WITH SLOPED END (4' CUTOFF WALL)**  
 NOT TO SCALE

CITY OF BOX ELDER  
 STANDARD DETAIL  
 CULVERT-PRECAST DOUBLE BOX-4'



DETAIL #RC046

REVISED 01/2020

# DETAIL RC050-CULVERT-SLOPE TRANSITIONS-TYPE-1

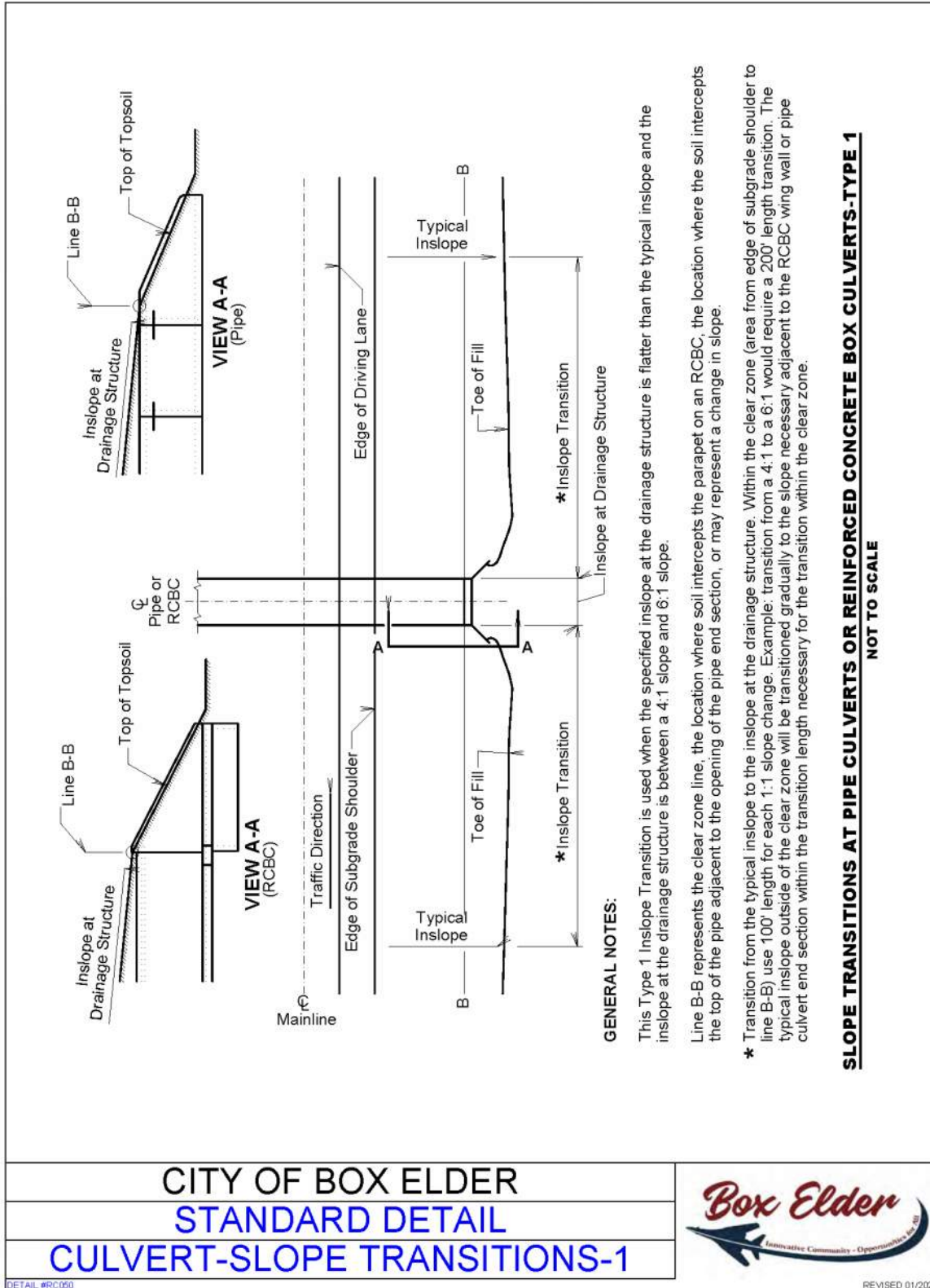

CITY OF BOX ELDER  
STANDARD DETAIL  
CULVERT-SLOPE TRANSITIONS-1



DETAIL #RC050

REVISED 01/2020

DETAIL RC051-CULVERT-SLOPE TRANSITIONS-TYPE-2

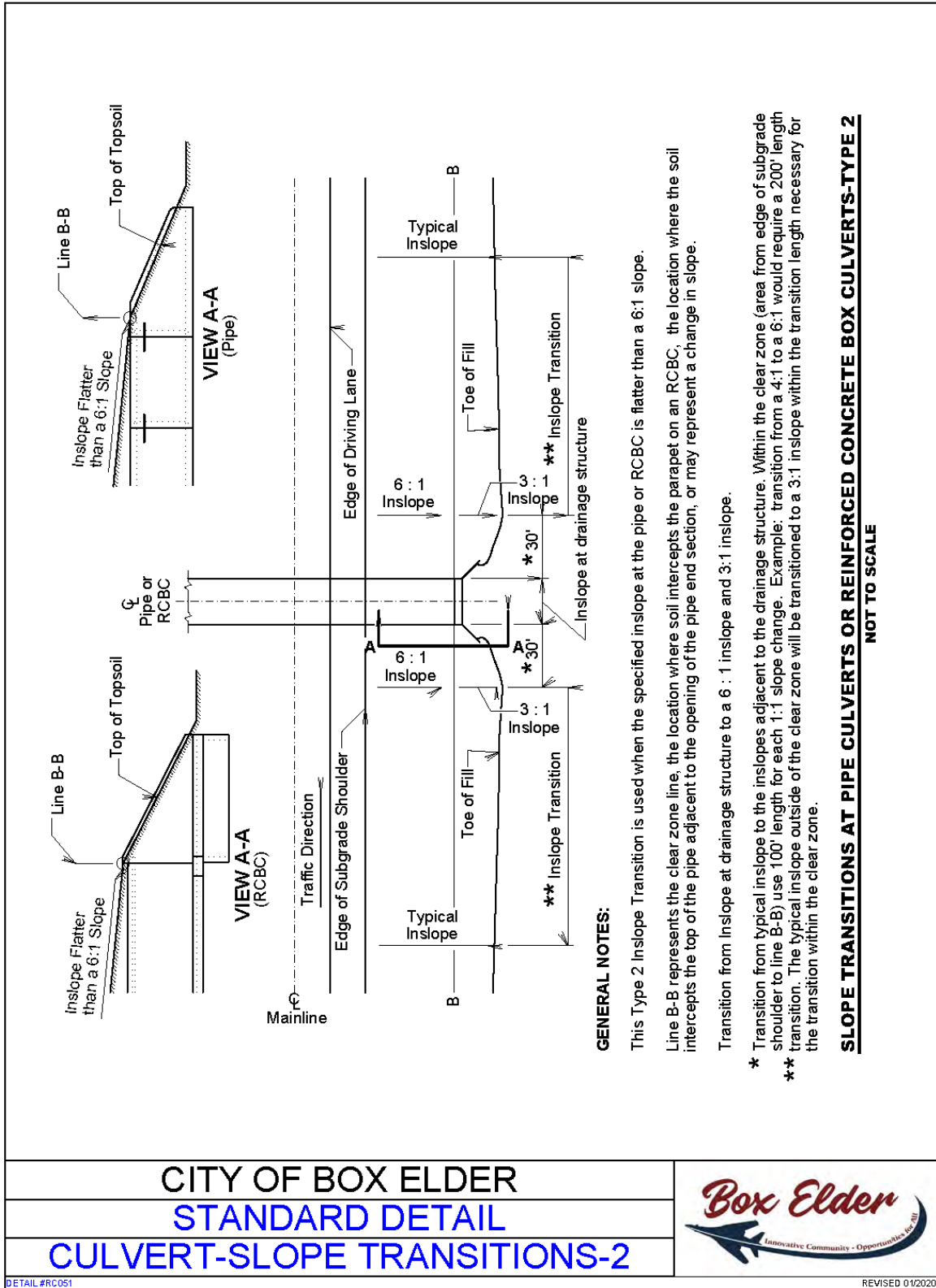

**GENERAL NOTES:**

This Type 2 Inslope Transition is used when the specified inslope at the pipe or RCBC is flatter than a 6:1 slope.

Line B-B represents the clear zone line, the location where soil intercepts the parapet on an RCBC, the location where the soil intercepts the top of the pipe adjacent to the opening of the pipe end section, or may represent a change in slope.

Transition from Inslope at drainage structure to a 6 : 1 inslope and 3:1 inslope.

- \* Transition from typical inslope to the inslopes adjacent to the drainage structure. Within the clear zone (area from edge of subgrade shoulder to line B-B) use 100' length for each 1:1 slope change. Example: transition from a 4:1 to a 6:1 would require a 200' length transition. The typical inslope outside of the clear zone will be transitioned to a 3:1 inslope within the transition length necessary for the transition within the clear zone.
- \*\*

**SLOPE TRANSITIONS AT PIPE CULVERTS OR REINFORCED CONCRETE BOX CULVERTS-TYPE 2**  
**NOT TO SCALE**

CITY OF BOX ELDER  
 STANDARD DETAIL  
 CULVERT-SLOPE TRANSITIONS-2



DETAIL #RC051

REVISED 01/2020

# DETAIL RD001-DROP INLET-CONCRETE-TYPE B (2X3)-1

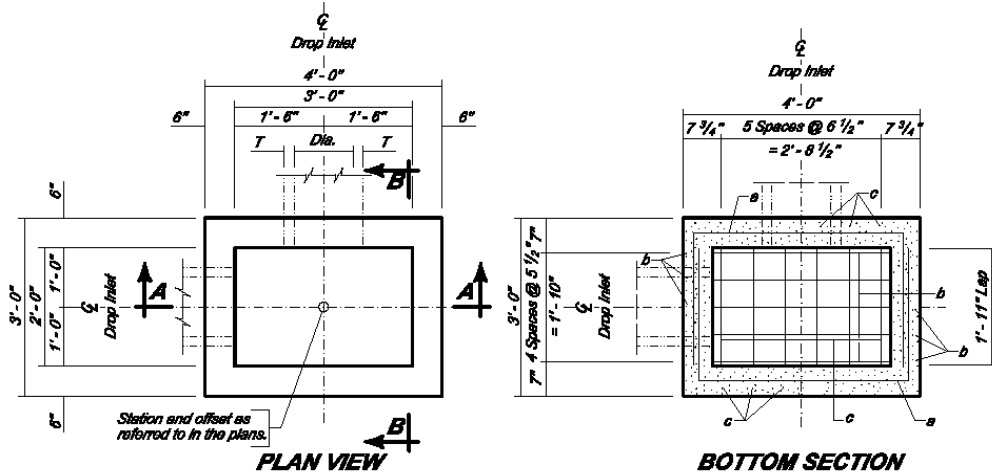

<b>ESTIMATED QUANTITIES</b>			
ITEM	UNIT	CONSTANT QUANTITY	VARIABLE QUANTITY
Class M8 Concrete	Cu. Yd.	0.26	0.22H
Reinforcing Steel	Lb.	83.03	28.97H
Frame and Grate Assembly	Each	1	—

## DROP INLETS FOR 12" TO 24" DIAMETER PIPE

### SPECIFICATIONS

*Design Specifications: AASHTO LRFD Bridge Design Specifications, current edition.*

*Construction Specifications: South Dakota Standard Specifications for Roads and Bridges, Current Edition and required Provisions, Supplemental Specifications, and Special Provisions as included in the Proposal.*

### GENERAL NOTES:

*Design Live Load: HL-93. No construction loading in excess of legal load was considered.*

*Reinforcing steel shall conform to ASTM A615 grade 60. The d bars shall be lapped 12 inches with the b and c bars. Cut and bend reinforcing steel as required to place pipe(s) through the drop inlet well.*

*Drop inlet may be precast. If precast drop inlet details differ from this standard plate, submit a checked design done by a SD registered P.E. and shop plan to the Engineer for approval.*

*Reduce total quantities of concrete by the amount of concrete displaced by the pipe(s). The total quantity of concrete shall be computed to the nearest hundredth of a cubic yard. The total quantity of reinforcing steel shall be computed to the nearest pound.*

*Drop inlet shown may be modified by the addition or omission of connecting pipes as noted elsewhere in the plans. All pipes entering drop inlet must fit between the inside face of walls and shall not enter through the corners.*

*Maximum R.C.P. diameter shall not exceed 18 inches on the 2-foot wide side and shall not exceed 24 inches (24 inches for R.C. arch) on the 3-foot wide side of the drop inlet.*

*The dimension of H is in feet. Maximum H is 10 feet.*

<b>PIPE DISPLACEMENT REDUCTIONS</b>		
Diameter (Inches)	Well T (Inches)	Class M8 Concrete (Cu. Yd.)
12	2	0.03
15	2 1/4	0.04
18	2 1/2	0.05
24	3	0.09
18	2 1/2	0.05
24	3 1/2	0.09

## DROP INLET-CONCRETE-TYPE B (2'X3') NOT TO SCALE

**CITY OF BOX ELDER**  
**STANDARD DETAIL**  
**DROP INLET-CONC.-TYPE B-2X3-1**



DETAIL #RD001

REVISED 01.2020

DETAIL RD002-DROP INLET-CONCRETE-TYPE B (2X3)-2

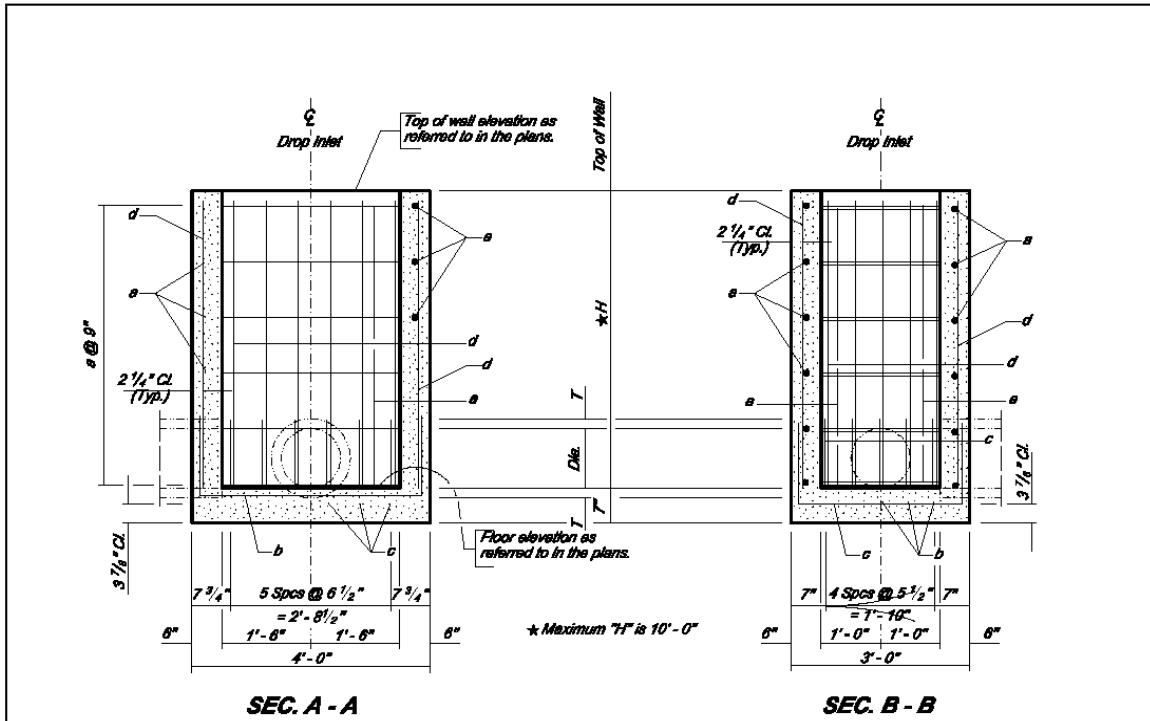

REINFORCING SCHEDULE				
Mk.	No.	Size	Length	Type
a	2.67H	4	8'-0"	17
b	5	5	6'-3"	17
c	6	4	5'-3"	17
d	22	4	H-2"	Str.

NOTE:  
All dimensions are out to out of bars.

Bending Details

**DROP INLET-CONCRETE-TYPE B (2'X3')**  
NOT TO SCALE

CITY OF BOX ELDER  
STANDARD DETAIL  
DROP INLET-CONC.-TYPE B-2X3-2



DETAIL #RD002

REVISED 01/2020

## DETAIL RD003-DROP INLET-CONCRETE-TYPE B (3X4)-1

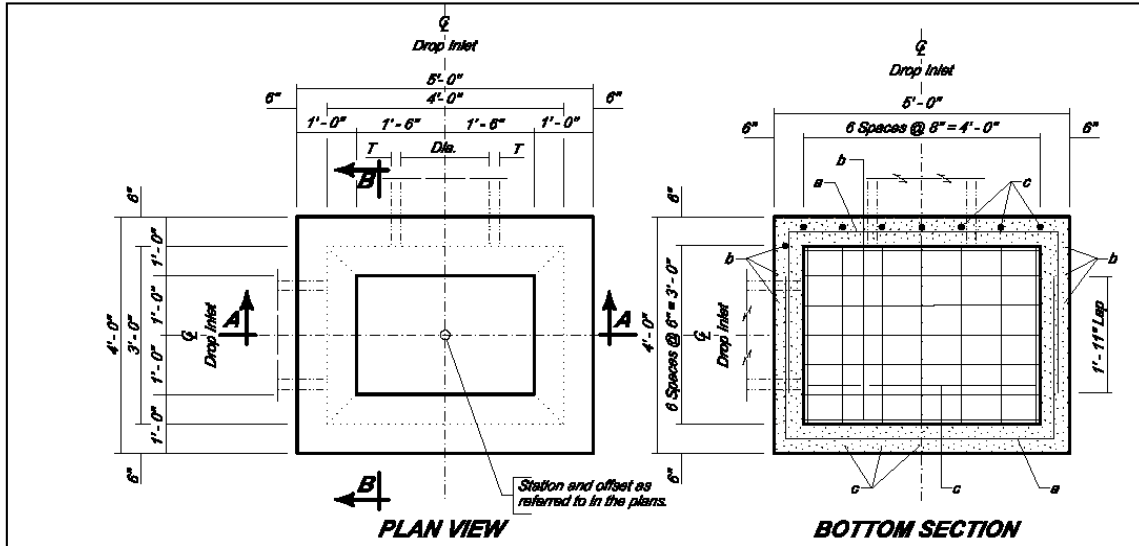

ESTIMATED QUANTITIES			
ITEM	UNIT	CONSTANT QUANTITY	VARIABLE QUANTITY
Class M6 Concrete	Cu. Yd.	0.72	0.30H
Reinforcing Steel	Lb.	130.93	36.64H
Frame and Grate Assembly	Each	1	

### DROP INLETS FOR 12" TO 36" DIAMETER PIPE

#### SPECIFICATIONS

*Design Specifications:* AASHTO LRFD Bridge Design Specifications, current edition.  
*Construction Specifications:* South Dakota Standard Specifications for Roads and Bridges, Current Edition and required Provisions, Supplemental Specifications, and Special Provisions as included in the Proposal.

#### GENERAL NOTES:

- Design Live Load:* HL-93. No construction loading in excess of legal load was considered.
- Reinforcing steel* shall conform to ASTM A615 grade 60. The d bars shall be lapped 12 inches with the b and c bars. Cut and bend reinforcing steel as required to place pipe(s) through the drop inlet wall.
- Drop inlet may be precast.* If precast drop inlet details differ from this standard plate, submit a checked design done by a SD registered P.E. and shop plans to the Engineer for approval.
- Reduce total quantities of concrete by the amount of concrete displaced by the pipe(s).* The total quantity of concrete shall be computed to the nearest hundredth of a cubic yard. The total quantity of reinforcing steel shall be computed to the nearest pound.
- Drop inlet shown may be modified by the addition or omission of connecting pipes as noted elsewhere in the plans.* All pipes entering drop inlet must fit between the inside face of walls and shall not enter through the corners.
- Maximum R.C.P. diameter shall not exceed 24 inches (24 inches for R. C. arch) on the 3-foot wide side and shall not exceed 36 inches (30 inches for R.C. arch) on the 4-foot wide side of the drop inlet.*
- The dimension of H is in feet. Maximum H is 10 feet.*

PIPE DISPLACEMENT REDUCTIONS		
Diameter (Inches)	Wall T (Inches)	Class M6 Concrete (Cu. Yd.)
12	2	0.03
15	2 1/4	0.04
18	2 1/2	0.05
24	3	0.09
30	3 1/2	0.14
36	4	0.20
R.C.P.		
18	2 1/2	0.05
24	3 1/2	0.09
30	4	0.14
R.C. ARCH		

### DROP INLET-CONCRETE-TYPE B (3'X4') NOT TO SCALE

CITY OF BOX ELDER  
STANDARD DETAIL  
DROP INLET-CONC.-TYPE B-3X4-1



DET.A11.RD003

REVISED 01/2020



## DETAIL RD004-DROP INLET-CONCRETE-TYPE B (3X4)-2

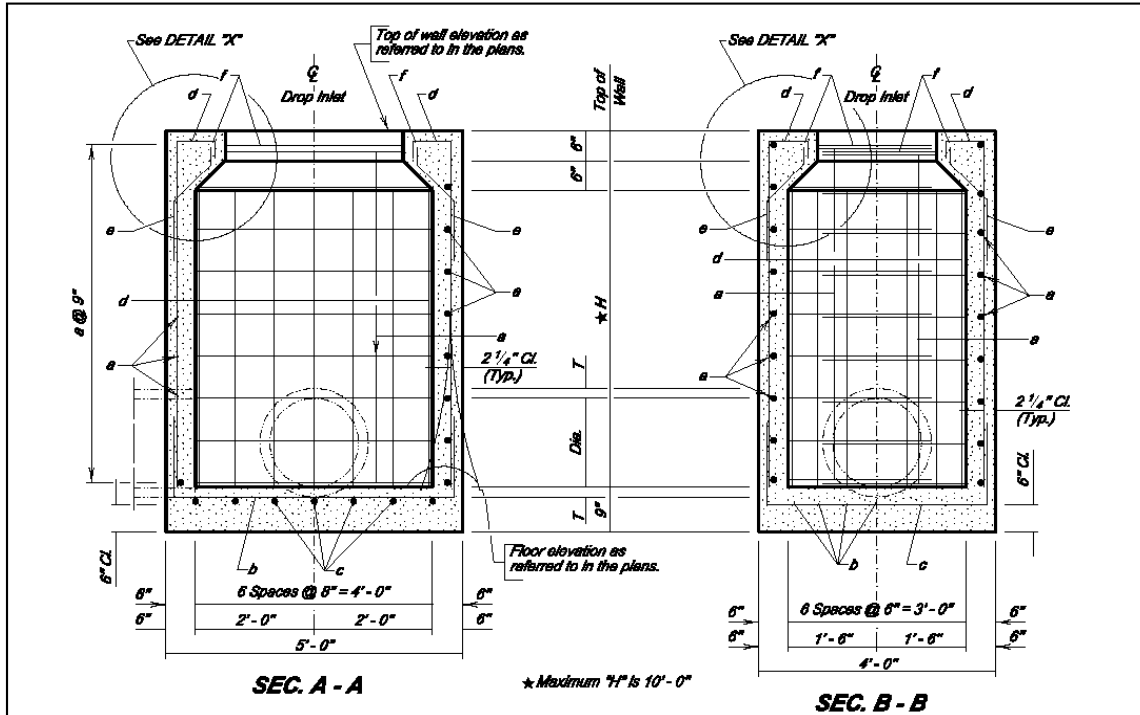

<b>REINFORCING SCHEDULE</b>				
MC	No.	Size	Length	Type
a	2.B7H	4	10'-0"	17
b	7	4	7'-6"	17
c	7	4	6'-6"	17
d	2B	4	H+9"	S17
e	2B	4	2'-3"	S19
f	2	4	7'-0"	17

  

**NOTE:**  
All dimensions are out to out of bars.

Type S17

Type 17

Type S19

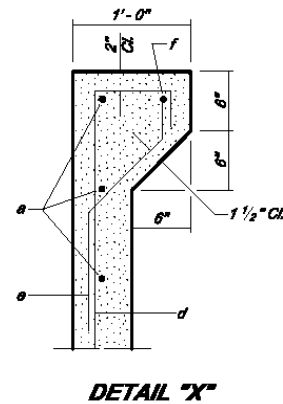

**DROP INLET-CONCRETE-TYPE B (3'X4')**  
NOT TO SCALE

**CITY OF BOX ELDER**  
**STANDARD DETAIL**  
**DROP INLET-CONC.-TYPE B-3X4-2**



DETAIL #RD004

REVISED 01.2020

# DETAIL RD005-DROP INLET-CONCRETE-TYPE B (3X5.5)-1

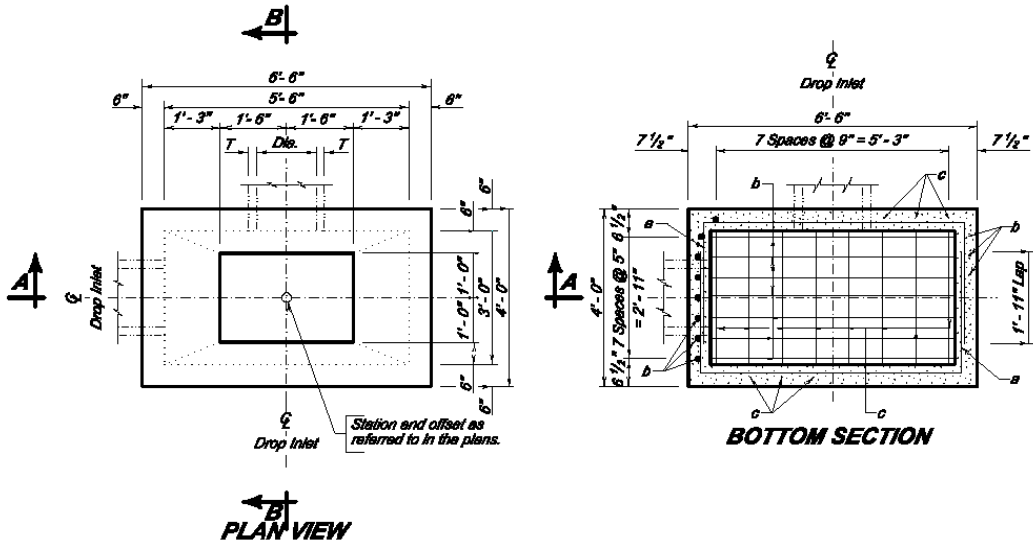

ESTIMATED QUANTITIES			
ITEM	UNIT	CONSTANT QUANTITY	VARIABLE QUANTITY
* Class M8 Concrete	Cu. Yd.	1.02	0.35H
Reinforcing Steel	Lb.	130.93	31.2H
Frame and Grate Assembly	Each	1	

### DROP INLETS FOR 12" TO 54" DIAMETER PIPE

**SPECIFICATIONS**  
 Design Specifications: AASHTO LRFD Bridge Design Specifications, current edition.  
 Construction Specifications: South Dakota Standard Specifications for Roads and Bridges, Current Edition and required Provisions, Supplemental Specifications, and Special Provisions as included in the Proposal.

**GENERAL NOTES**  
 Design Live Load: HL-93. No construction loading in excess of legal load was considered.  
 Reinforcing steel shall conform to ASTM A615 grade 60. The d and e bars shall be lapped 12 inches with the c and b bars, respectively. Cut and bend reinforcing steel as required to place pipe(s) through the drop inlet well.  
 Drop inlet may be precast. If precast drop inlet details differ from this standard plate, submit a checked design done by a SD registered P.E. and shop plans to the Engineer for approval.  
 \* Reduce total quantities of concrete by the amount of concrete displaced by the pipe(s). The total quantity of concrete shall be computed to the nearest hundredth of a cubic yard. The total quantity of reinforcing steel shall be computed to the nearest pound.  
 Drop inlet shown may be modified by the addition or omission of connecting pipes as noted elsewhere in the plans. All pipes entering drop inlet must fit between the inside face of walls and shall not enter through the corners.  
 Maximum R.C.P. diameter shall not exceed 24 inches (24 inches for R. C. arch) on the 3-foot wide side and shall not exceed 54 inches (42 inches for R. C. arch) on the 5.5-foot wide side of the drop inlet.  
 The dimension of H is in feet. Maximum H is 10 feet.

PIPE DISPLACEMENT REDUCTIONS		
Diameter (Inches)	Well T (Inches)	Class M8 Concrete (Cu. Yd.)
12	2	0.03
15	2 1/4	0.04
18	2 1/2	0.05
24	3	0.09
30	3 1/2	0.14
36	4	0.20
42	4 1/2	0.28
48	5	0.34
54	5 1/2	0.43
<b>R.C.P.</b>		
18	2 1/2	0.05
24	3 1/2	0.09
30	4	0.14
36	4 1/2	0.19
42	4 1/2	0.24
<b>R.C. ARCH</b>		

### DROP INLET-CONCRETE-TYPE B (3'X5.5') NOT TO SCALE

CITY OF BOX ELDER  
STANDARD DETAIL  
DROP INLET-CONC.-TYPE B-3X5.5-1



DET.A11.RD005

REVISED 01/2020

## DETAIL RD006-DROP INLET-CONCRETE-TYPE B (3X5.5)-2

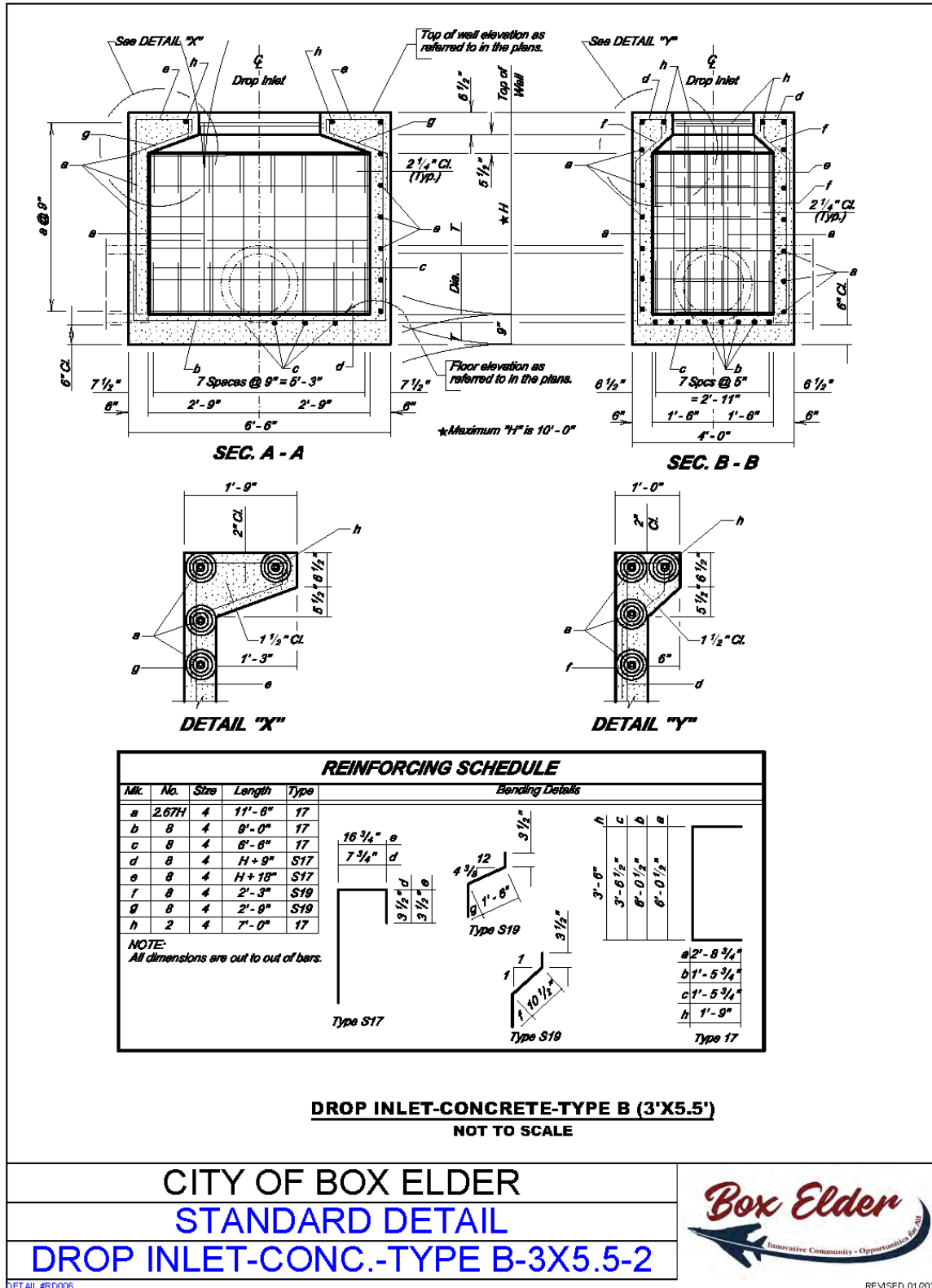

# DETAIL RD007-DROP INLET-CONCRETE-TYPE B (4X4)-1

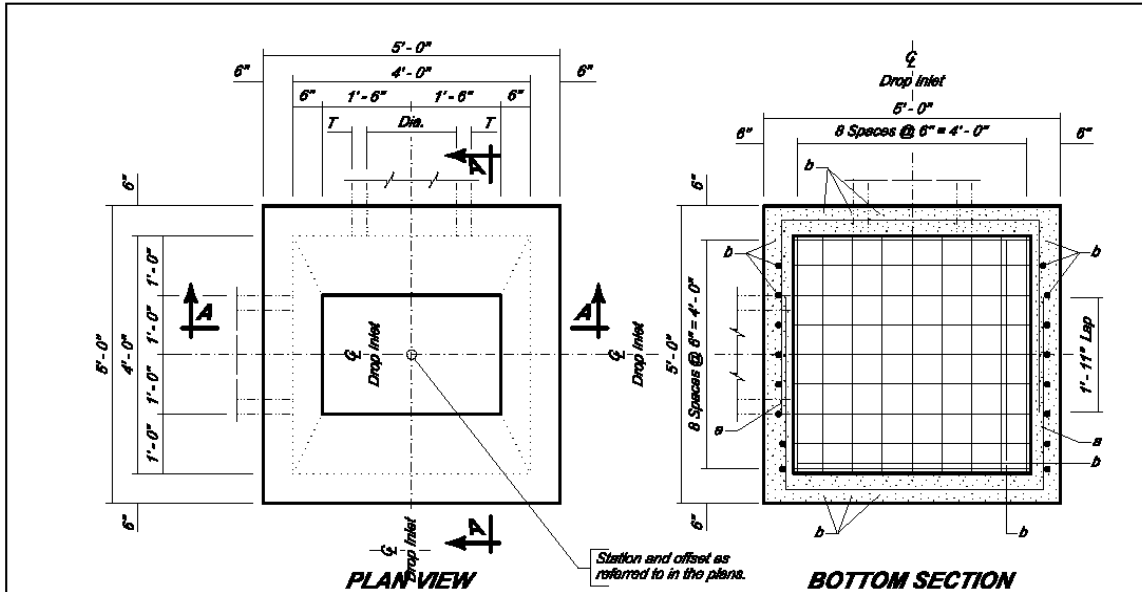

ESTIMATED QUANTITIES			
ITEM	UNIT	CONSTANT QUANTITY	VARIABLE QUANTITY
Class M8 Concrete	Cu. Yd.	0.98	0.33H
Reinforcing Steel	Lb.	180.69	43.67H
Frame and Grate Assembly	Each	1	—

## DROP INLETS FOR 12" TO 36" DIAMETER PIPE

### SPECIFICATIONS

*Design Specifications: AASHTO LRFD Bridge Design Specifications, current edition.*

*Construction Specifications: South Dakota Standard Specifications for Roads and Bridges, Current Edition and required Provisions, Supplemental Specifications, and Special Provisions as included in the Proposal.*

### GENERAL NOTES:

*Design Live Load: HL-93. No construction loading in excess of legal load was considered.*

*Reinforcing steel shall conform to ASTM A616 grade 60. The d bars shall be lapped 12 inches with the b and c bars. Cut and bend reinforcing steel as required to place pipe(s) through the drop inlet wall.*

*Drop inlet may be precast. If precast drop inlet details differ from this standard plate, submit a checked design done by a SD registered P.E. and shop plans to the Engineer for approval.*

*Reduce total quantities of concrete by the amount of concrete displaced by the pipe(s). The total quantity of concrete shall be computed to the nearest hundredth of a cubic yard. The total quantity of reinforcing steel shall be computed to the nearest pound.*

*Drop inlet shown may be modified by the addition or omission of connecting pipes as noted elsewhere in the plans. All pipes entering drop inlet must fit between the inside face of walls and shall not enter through the corners.*

*Maximum R.C.P. diameter shall not exceed 36 inches (30 inches for R. C. arch) on the 4-foot wide side of the drop inlet.*

*The dimension of H is in feet. Maximum H is 10 feet.*

PIPE DISPLACEMENT REDUCTIONS		
Diameter (Inches)	Wall T (Inches)	Class M8 Concrete (Cu. Yd.)
12	2	0.03
15	2 1/4	0.04
18	2 1/2	0.05
24	3	0.09
30	3 1/2	0.14
36	4	0.20
18	2 1/2	0.05
24	3 1/2	0.09
30	4	0.14

## DROP INLET-CONCRETE-TYPE B (4'X4')

NOT TO SCALE

CITY OF BOX ELDER  
**STANDARD DETAIL**  
 DROP INLET-CONC.-TYPE B-4X4-1



DETAIL RD007

REVISED: 01/2020

## DETAIL RD008-DROP INLET-CONCRETE-TYPE B (4X4)-2

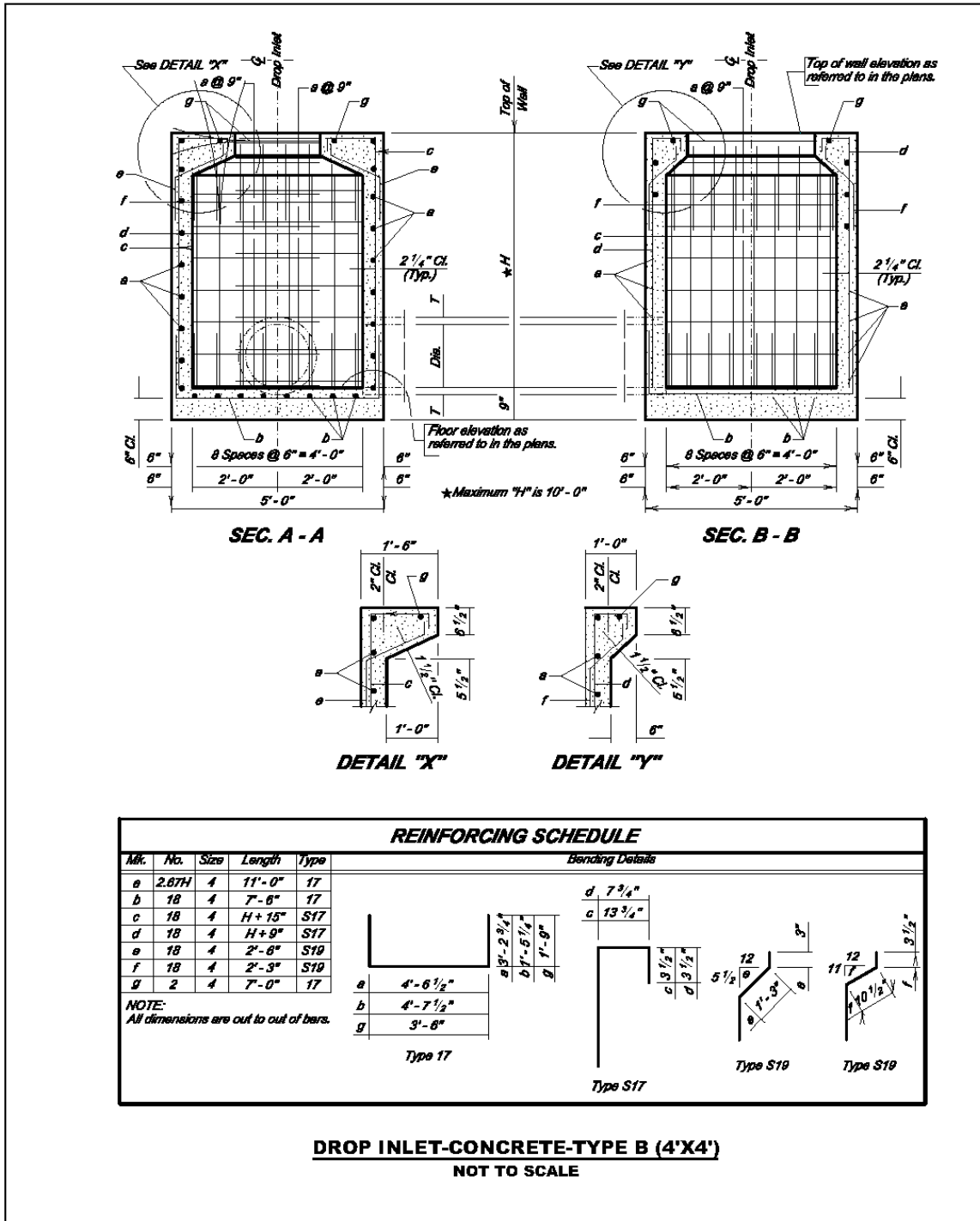

**DROP INLET-CONCRETE-TYPE B (4'X4')**  
NOT TO SCALE

CITY OF BOX ELDER  
STANDARD DETAIL  
DROP INLET-CONC.-TYPE B-4X4-2



DETAIL #RD008

REVISED: 01/2020

## DETAIL RD009-DROP INLET-CONCRETE-TYPE B (5.5X3)-1

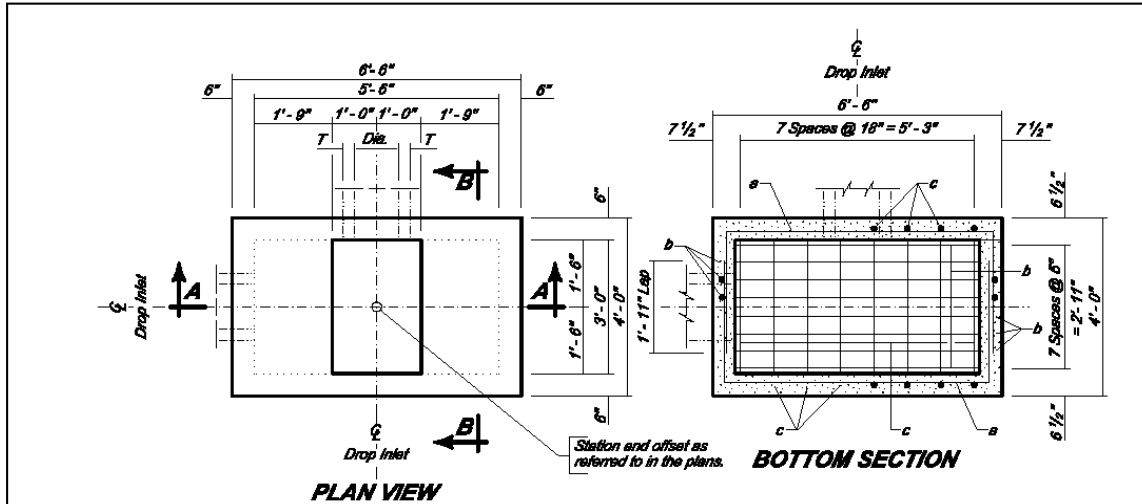

<b>ESTIMATED QUANTITIES</b>			
ITEM	UNIT	CONSTANT QUANTITY	VARIABLE QUANTITY
Class M6 Concrete	Cu. Yd.	1.03	0.35H
Reinforcing Steel	Lb.	161.19	47.89H
Grate Assembly	Each	1	

### DROP INLETS FOR 12" TO 54" DIAMETER PIPE

#### SPECIFICATIONS

*Design Specifications: AASHTO LRFD Bridge Design Specifications, current edition.*

*Construction Specifications: South Dakota Standard Specifications for Roads and Bridges, Current Edition and required Provisions, Supplemental Specifications, and Special Provisions as included in the Proposal.*

#### GENERAL NOTES:

*Design Live Load: HL-93. No construction loading in excess of legal load was considered.*

*Reinforcing steel shall conform to ASTM A615 grade 60. The d bars shall be lapped 12 inches with the b and c bars. Cut and bend reinforcing steel as required to place pipe(s) through the drop inlet well.*

*Drop inlet may be precast. If precast drop inlet details differ from this standard plate, submit a checked design done by a SD registered P.E. and shop plans to the Engineer for approval.*

*Reduce total quantities of concrete by the amount of concrete displaced by the pipe(s). The total quantity of concrete shall be computed to the nearest hundredth of a cubic yard. The total quantity of reinforcing steel shall be computed to the nearest pound.*

*Drop inlet shown may be modified by the addition or omission of connecting pipes as noted elsewhere in the plans. All pipes entering drop inlet must fit between the inside face of walls and shall not enter through the corners.*

*Maximum R.C.P. diameter shall not exceed 54 inches (42 inches for R. C. arch) on the 5.5-foot wide side and shall not exceed 24 inches (24 inches for R. C. arch) on the 3-foot wide side of the drop inlet.*

*The dimension of H is in feet. Maximum H is 10 feet.*

<b>PIPE DISPLACEMENT REDUCTIONS</b>		
Diameter (Inches)	Well T (Inches)	Class M6 Concrete (Cu. Yd.)
12	2	0.03
15	2 1/4	0.04
18	2 1/2	0.05
24	3	0.09
30	3 1/2	0.14
36	4	0.20
42	4 1/2	0.26
48	5	0.34
54	5 1/2	0.43
18	2 1/2	0.05
24	3 1/2	0.09
30	4	0.14
36	4 1/2	0.19
42	4 1/2	0.24

### DROP INLET-CONCRETE-TYPE B (5.5'x3') NOT TO SCALE

<b>CITY OF BOX ELDER</b> <b>STANDARD DETAIL</b> <b>DROP INLET-CONC.-TYPE B-5.5X3-1</b>
--



DETAIL #RD009

REVISED 01/2020

## DETAIL RD010-DROP INLET-CONCRETE-TYPE B (5.5X3)-2

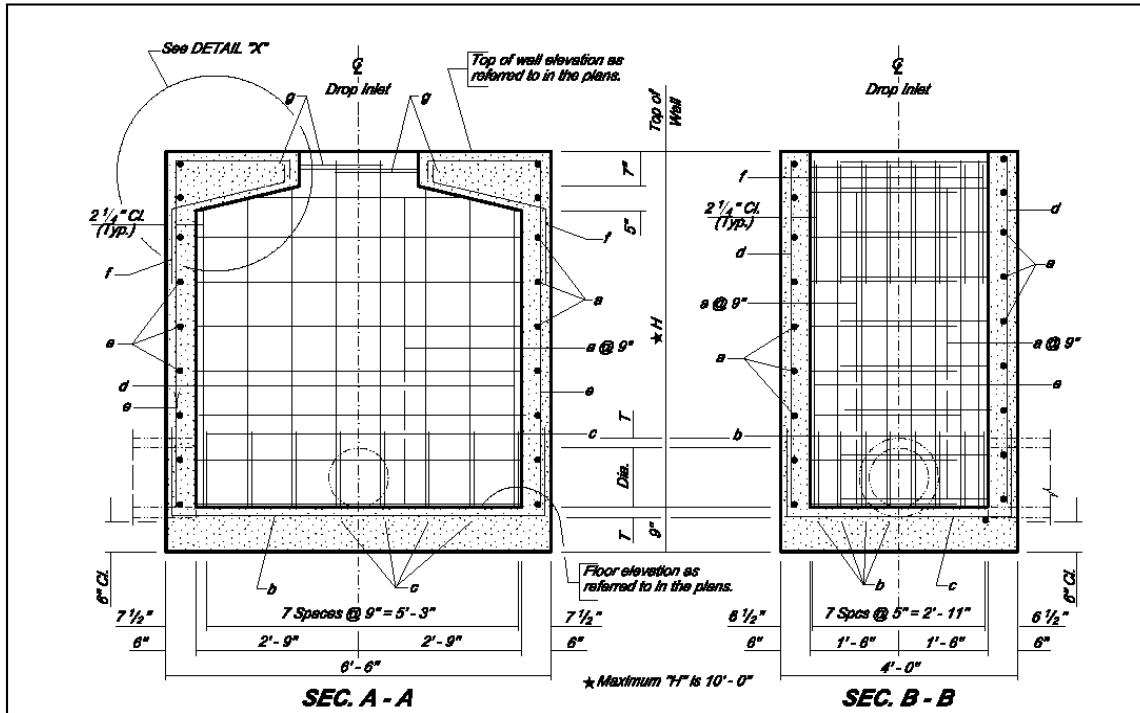

<b>REINFORCING SCHEDULE</b>				
Mk.	No.	Size	Length	Type
a	2,67H	4	11'-5"	17
b	8	4	9'-0"	17
c	8	4	6'-6"	17
d	16	4	H-2" Str.	
e	16	5	H+24"	S17
f	16	4	3'-6"	S19
g	2	4	7'-0"	17

**NOTE:**  
All dimensions are out to out of bars.

Type S17

Type S19

<b>Bending Details</b>				
	a	c	d	e
	3'-6"	3'-6 1/2"	6'-0 1/2"	6'-0 1/2"
	a 2'-8 3/4"	b 1'-6 3/4"	c 1'-5 3/4"	g 1'-9"

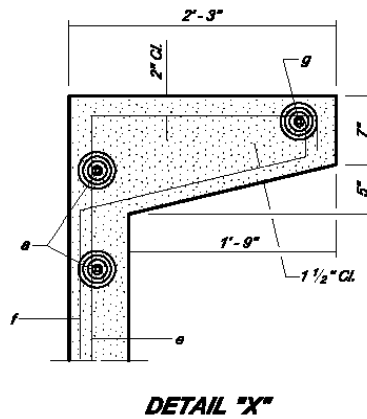

**DROP INLET-CONCRETE-TYPE B (5.5'X3')**  
NOT TO SCALE

CITY OF BOX ELDER  
STANDARD DETAIL  
DROP INLET-CONC.-TYPE B-5.5X3-2



DETAIL #RD010

REVISED 01/2020

# DETAIL RD011-DROP INLET-CONCRETE-TYPE B (5.5X5.5)-1

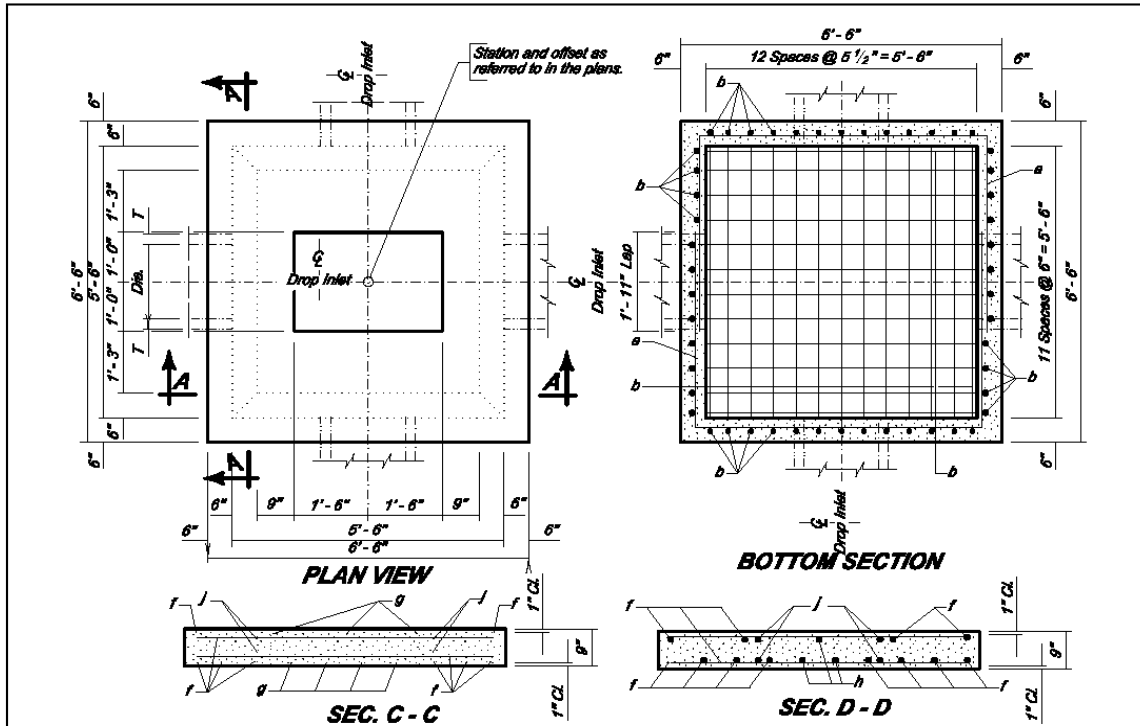

**DROP INLETS FOR 12" TO 54" DIAMETER PIPE**

**SPECIFICATIONS**

*Design Specifications: AASHTO LRFD Bridge Design Specifications, current edition.*

*Construction Specifications: South Dakota Standard Specifications for Roads and Bridges, Current Edition and required Provisions, Supplemental Specifications, and Special Provisions as included in the Proposal.*

**GENERAL NOTES:**

*Design Live Load: HL-93. No construction loading in excess of legal load was considered.*

*Reinforcing steel shall conform to ASTM A615 grade 60. The c bars shall be lapped 12 inches with the b bars. Cut and bend reinforcing steel as required to place pipe(s) through the drop inlet wall.*

*Drop inlet may be precast. If precast drop inlet details differ from this standard plate, submit a checked design done by a SD registered P.E. and shop plans to the Engineer for approval.*

*\* Reduce total quantities of concrete by the amount of concrete displaced by the pipe(s). The total quantity of concrete shall be computed to the nearest hundredth of a cubic yard. The total quantity of reinforcing steel shall be computed to the nearest pound.*

*Apply a thin layer of grout between the drop inlet and cover to ensure uniform bearing. Grout shall conform to the specifications.*

*Drop inlet shown may be modified by the addition or omission of connecting pipes as noted elsewhere in the plans. All pipes entering drop inlet must fit between the inside face of walls and shall not enter through the corners.*

*Maximum R.C.P. diameter shall not exceed 54 inches (42 inches for R. C. arch) of the drop inlet.*

*The dimension of H is in feet. Maximum H is 10 feet.*

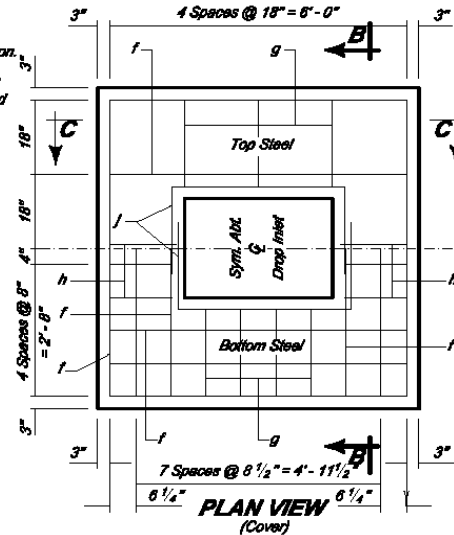

**DROP INLET-CONCRETE-TYPE B (5.5'X5.5')**  
NOT TO SCALE

**CITY OF BOX ELDER**  
**STANDARD DETAIL**  
**DROP INLET-CONC.-TYPE B-5.5X5.5-1**



DETAIL #RD011

REVISED 01/2020



## DETAIL RD012-DROP INLET-CONCRETE-TYPE B (5.5X5.5)-2

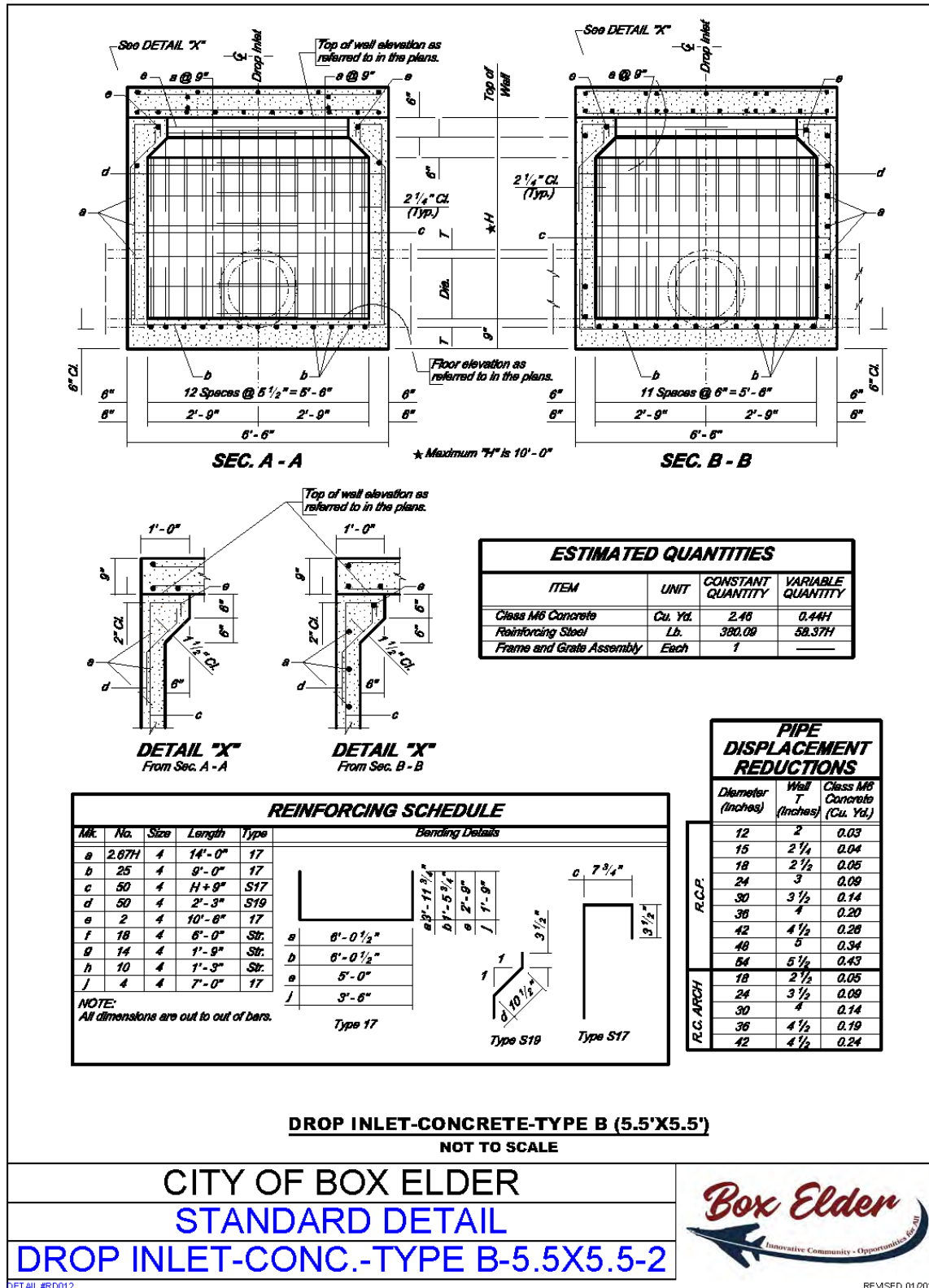

# DETAIL RD013-DROP INLET-CONCRETE-TYPE B (4X3)-1

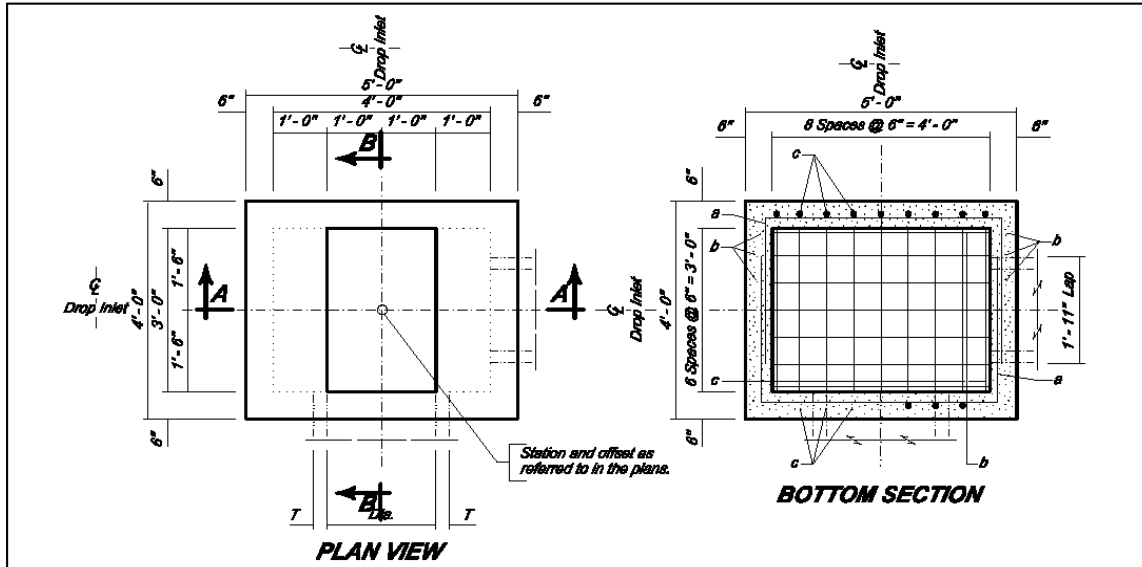

<b>ESTIMATED QUANTITIES</b>			
ITEM	UNIT	CONSTANT QUANTITY	VARIABLE QUANTITY
‡ Class M6 Concrete	Cu. Yd.	0.58	0.33H
Reinforcing Steel	Lb.	116.24	39.21H
Frame and Grate Assembly	Each	1	—

## DROP INLETS FOR 12" TO 36" DIAMETER PIPE

### SPECIFICATIONS

*Design Specifications: AASHTO LRFD Bridge Design Specifications, current edition.*

*Construction Specifications: South Dakota Standard Specifications for Roads and Bridges, Current Edition and required Provisions, Supplemental Specifications, and Special Provisions as included in the Proposal.*

### GENERAL NOTES:

*Design Live Load: HL-93. No construction loading in excess of legal load was considered.*

*Reinforcing steel shall conform to ASTM A615 grade 60. The d and e bars shall be lapped 12 inches with the c and b bars, respectively. Cut and bend reinforcing steel as required to place pipe(s) through the drop inlet well.*

*Drop inlet may be precast. If precast drop inlet details differ from this standard plate, submit a checked design done by a SD registered P.E. and shop plans to the Engineer.*

\* *Reduce total quantities of concrete by the amount of concrete displaced by the pipe(s). The total quantity of concrete shall be computed to the nearest hundredth of a cubic yard. The total quantity of reinforcing steel shall be computed to the nearest pound.*

*Drop inlet shown may be modified by the addition or omission of connecting pipes as noted elsewhere in the plans. All pipes entering drop inlet must fit between the inside face of wells and shall not enter through the corners.*

*Maximum R.C.P. diameter shall not exceed 36 inches (30 inches for R. C. arch) on the 4-foot wide side and shall not exceed 24 inches (24 inches for R. C. arch) on the 3-foot wide side of the drop inlet.*

*The dimension of H is in feet. Maximum H is 10 feet.*

### PIPE DISPLACEMENT REDUCTIONS

Diameter (Inches)	Well T (Inches)	Class M6 Concrete (Cu. Yd.)
12	2	0.03
15	2 1/4	0.04
18	2 1/2	0.05
24	3	0.08
30	3 1/2	0.14
36	4	0.20
18	2 1/2	0.05
24	3 1/2	0.09
30	4	0.14

## DROP INLET-CONCRETE-TYPE B (4'X3')

NOT TO SCALE

<b>CITY OF BOX ELDER</b> <b>STANDARD DETAIL</b> <b>DROP INLET-CONC.-TYPE B-4X3-1</b>
--



DETAIL #RD013

REVISED 01/2020

## DETAIL RD014-DROP INLET-CONCRETE-TYPE B (4X3)-2

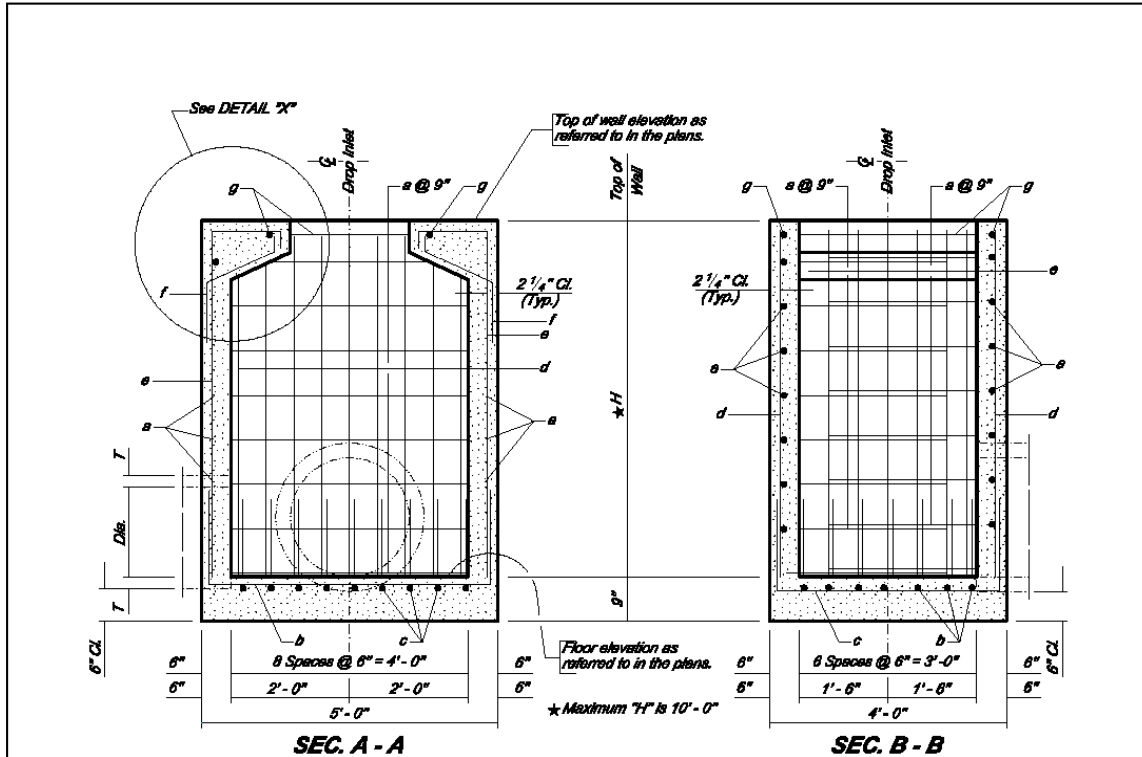

<b>REINFORCING SCHEDULE</b>				
Mk	No.	Size	Length	Type
a	2.67H	4	10'-0"	17
b	7	4	7'-6"	17
c	8	4	6'-6"	17
d	18	4	H - 2"	Str.
e	14	4	H + 15"	S17
f	14	4	2'-6"	S19
g	2	4	6'-8"	17

  

**NOTE:**  
All dimensions are out to out of bars.

Type 17

Type S19

Type S17

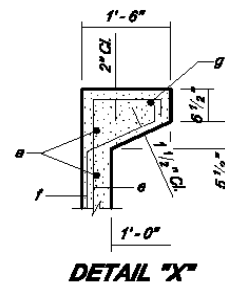

**DROP INLET-CONCRETE-TYPE B (4'X3')**  
NOT TO SCALE

CITY OF BOX ELDER  
STANDARD DETAIL  
DROP INLET-CONC.-TYPE B-4X3-2



DETAIL #RD014

REVISED 01/2020

# DETAIL RD015-DROP INLET-CONCRETE-TYPE C (3X4)-1

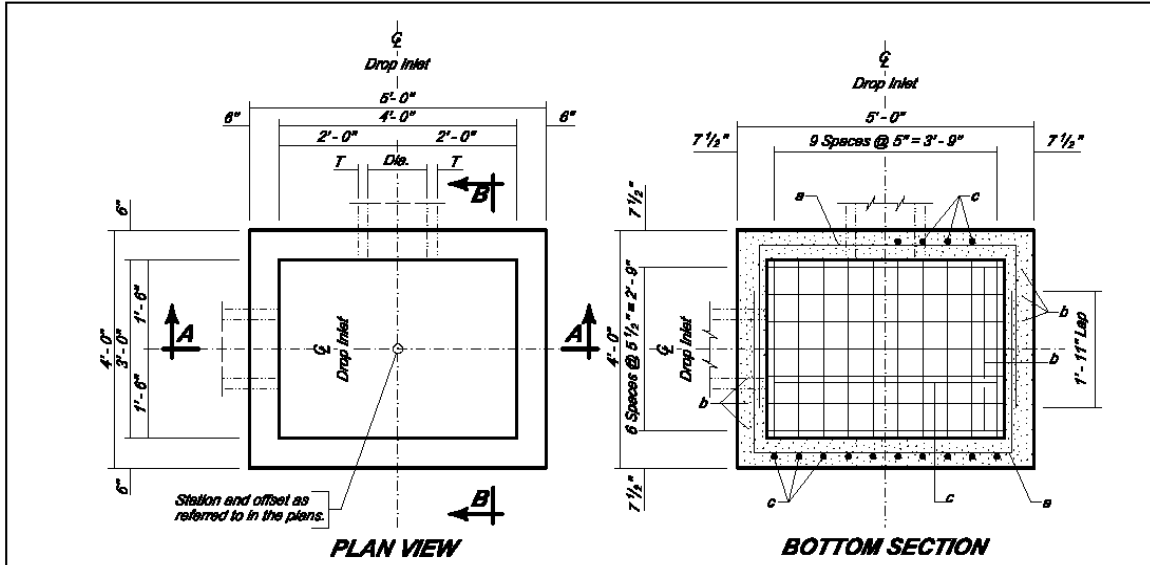

ESTIMATED QUANTITIES			
ITEM	UNIT	CONSTANT QUANTITY	VARIABLE QUANTITY
* Class M8 Concrete	Cu. Yd.	0.43	0.30H
Reinforcing Steel	Lb.	90.90	40.63H
Frame and Grate Assembly	Each	1	

### DROP INLETS FOR 12" TO 36" DIAMETER PIPE

#### SPECIFICATIONS

*Design Specifications: AASHTO LRFD Bridge Design Specifications, current edition.*

*Construction Specifications: South Dakota Standard Specifications for Roads and Bridges, Current Edition and required Provisions, Supplemental Specifications, and Special Provisions as included in the Proposal.*

#### GENERAL NOTES:

*Design Live Load: HL-93. No construction loading in excess of legal load was considered.*

*Reinforcing steel shall conform to ASTM A615 grade 80. The d bars shall be lapped 12 inches with the b and c bars. Cut and bend reinforcing steel as required to place pipe(s) through the drop inlet wall.*

*Drop inlet may be precast. If precast drop inlet details differ from this standard plate, submit a checked design done by a SD registered P.E. and shop plans to the Engineer for approval.*

\* *Reduce total quantities of concrete by the amount of concrete displaced by the pipe(s). The total quantity of concrete shall be computed to the nearest hundredth of a cubic yard. The total quantity of reinforcing steel shall be computed to the nearest pound.*

*Drop inlet shown may be modified by the addition or omission of connecting pipes as noted elsewhere in the plans. All pipes entering drop inlet must fit between the inside face of walls and shall not enter through the corners.*

*Maximum R.C.P. diameter shall not exceed 24 inches (24 inches for R. C. arch) on the 3-foot wide side and shall not exceed 36 inches (30 inches for R. C. arch) on the 4-foot wide side of the drop inlet.*

*The dimension of H is in feet. Maximum H is 10 feet.*

PIPE DISPLACEMENT REDUCTIONS		
Diameter (Inches)	Wall T (Inches)	Class M8 Concrete (Cu. Yd.)
12	2	0.03
15	2 1/4	0.04
18	2 1/2	0.05
24	3	0.09
30	3 1/2	0.14
36	4	0.20
18	2 1/2	0.05
24	3 1/2	0.09
30	4	0.14

### DROP INLET-CONCRETE-TYPE C (3'X4') NOT TO SCALE

CITY OF BOX ELDER

STANDARD DETAIL

DROP INLET-CONC.-TYPE C-3X4-1



DETAIL #RD015

REVISED 01/2020

DETAIL RD016-DROP INLET-CONCRETE-TYPE C (3X4)-2

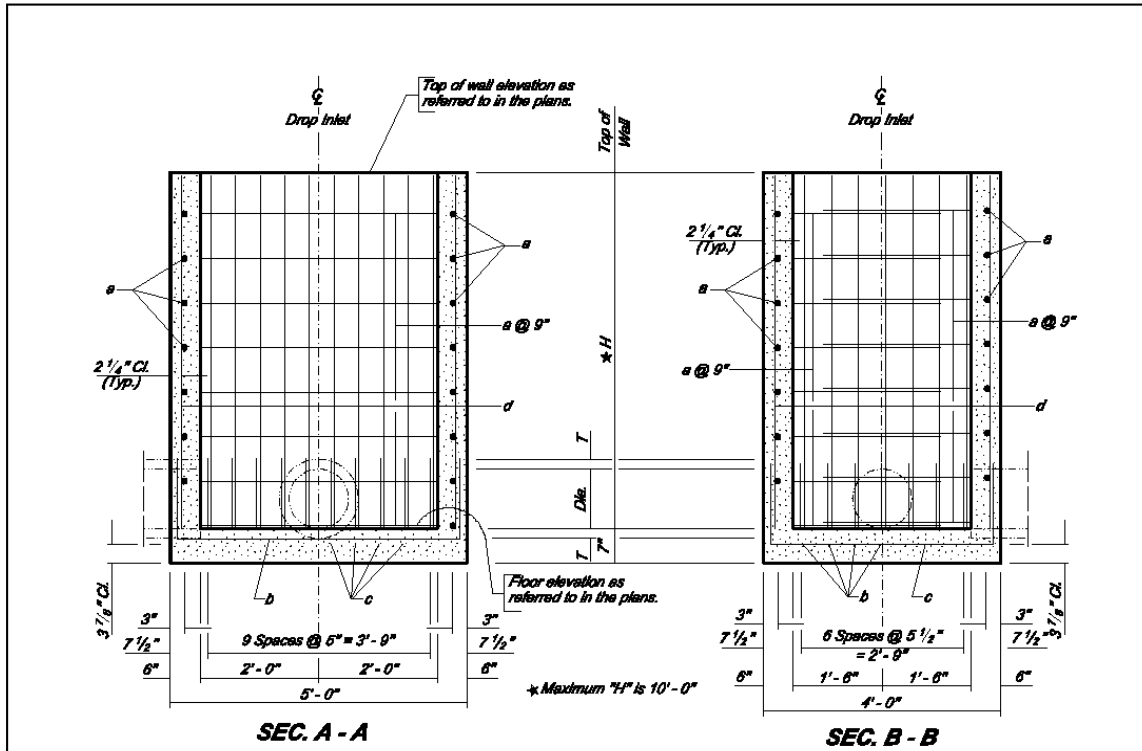

REINFORCING SCHEDULE				
Mk.	No.	Size	Length	Type
a	2.67H	4	10'-0"	17
b	7	5	7'-3"	17
c	10	4	8'-3"	17
d	34	4	H - 2"	Str.

Bending Details		
c	b	a
3'-6 1/2"	4'-6 1/2"	4'-6 1/2"
a	2'-8 3/4"	
b	7'-4 1/4"	
c	7'-4 1/4"	
Type 17		

NOTE:  
All dimensions are out to out of bars.

**DROP INLET-CONCRETE-TYPE C (3'X4')**  
NOT TO SCALE

CITY OF BOX ELDER  
STANDARD DETAIL  
DROP INLET-CONC.-TYPE C-3X4-2



DETAIL #RD016

REVISED 01/2020

# DETAIL RD017-DROP INLET-CONCRETE-TYPE C (4X5)-1

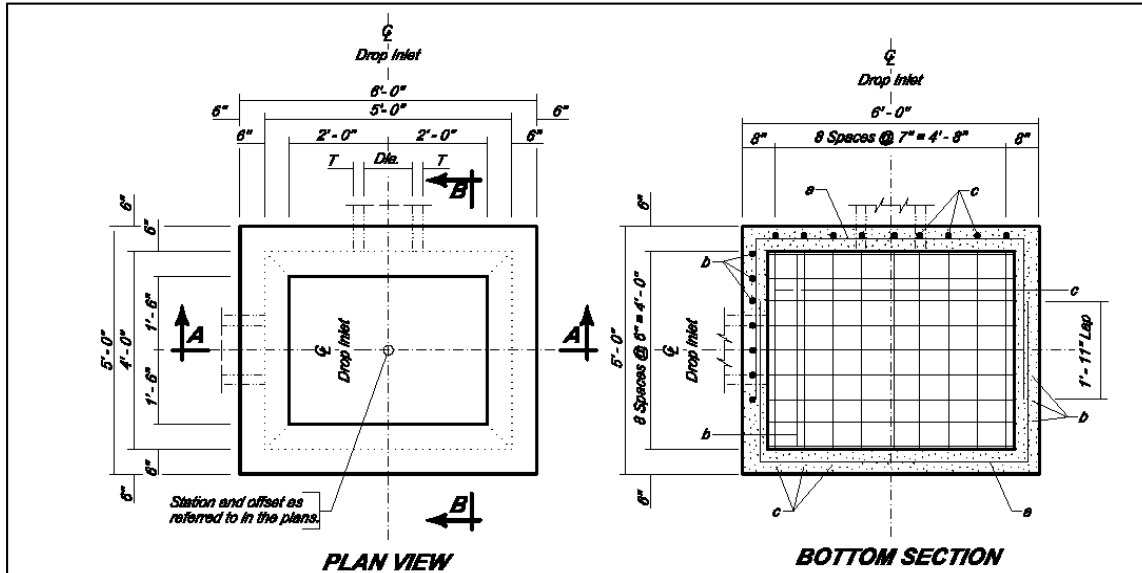

ESTIMATED QUANTITIES			
ITEM	UNIT	CONSTANT QUANTITY	VARIABLE QUANTITY
* Class MB Concrete	Cu. Yd.	1.08	0.37H
Reinforcing Steel	Lb.	160.36	45.43H
Frame and Grate Assembly	Each	1	—

### DROP INLETS FOR 12" TO 48" DIAMETER PIPE

#### SPECIFICATIONS

*Design Specifications: AASHTO LRFD Bridge Design Specifications, current edition.*

*Construction Specifications: South Dakota Standard Specifications for Roads and Bridges, Current Edition and required Provisions, Supplemental Specifications, and Special Provisions as included in the Proposal.*

#### GENERAL NOTES:

*Design Live Load: HL-93. No construction loading in excess of legal load was considered.*

*Reinforcing steel shall conform to ASTM A615 grade 60. The d bars shall be lapped 12 inches with the b and c bars. Cut and bend reinforcing steel as required to place pipe(s) through the drop inlet wall.*

*Drop inlet may be precast. If precast drop inlet details differ from this standard plate, submit a checked design done by a SD registered P.E. and Engineer for approval.*

\* *Reduce total quantities of concrete by the amount of concrete displaced by the pipe(s). The total quantity of concrete shall be computed to the nearest hundredth of a cubic yard. The total quantity of reinforcing steel shall be computed to the nearest pound.*

*Drop inlet shown may be modified by the addition or omission of connecting pipes as noted elsewhere in the plans. All pipes entering drop inlet must fit between the inside face of walls and shall not enter through the corners.*

*Maximum R.C.P. diameter shall not exceed 36 inches (30 inches for R. C. arch) on the 4-foot wide side and shall not exceed 48 inches (36 inches for R. C. arch) on the 5-foot wide side of the drop inlet. The dimension of H is in feet. Maximum H is 10 feet.*

#### PIPE DISPLACEMENT REDUCTIONS

Diameter (Inches)	Wall T (Inches)	Class MB Concrete (Cu. Yd.)
12	2	0.03
15	2 1/4	0.04
18	2 1/2	0.05
24	3	0.09
30	3 1/2	0.14
36	4	0.20
42	4 1/2	0.28
48	5	0.34
18	2 1/2	0.05
24	3 1/2	0.09
30	4	0.14
36	4 1/2	0.19

### DROP INLET-CONCRETE-TYPE C (4'X5')

NOT TO SCALE

CITY OF BOX ELDER
STANDARD DETAIL
DROP INLET-CONC.-TYPE C-4X5-1



DETAIL #RD017

REVISED 01/2020

DETAIL RD018-DROP INLET-CONCRETE-TYPE C (4X5)-2

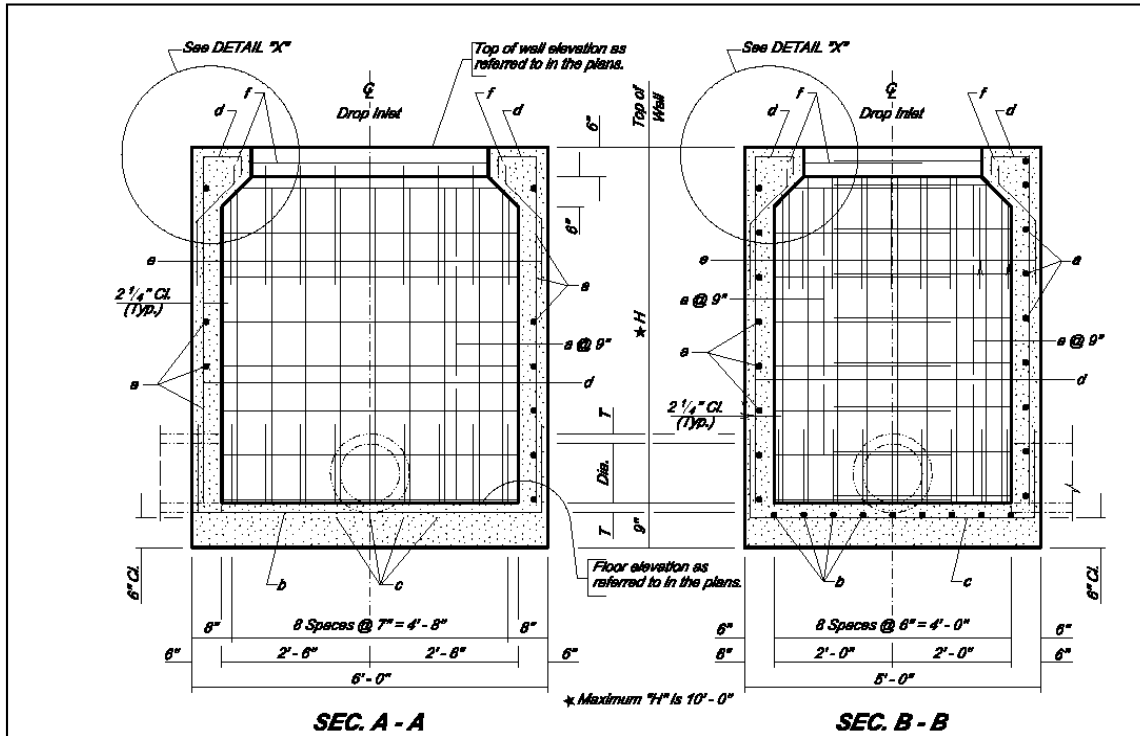

**REINFORCING SCHEDULE**

Mk.	No.	Size	Length	Type	Banding Details
a	2.67H	4	12'-0"	17	
b	9	4	8'-8"	17	
c	9	4	7'-8"	17	
d	36	4	H + 8"	S17	
e	36	4	2'-3"	S19	
f	2	4	9'-0"	17	

**NOTE:**  
All dimensions are out to out of bars.

Type S17

Type S19

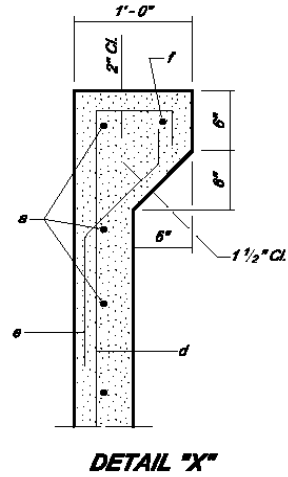

**DROP INLET-CONCRETE-TYPE C (4'X5')**  
NOT TO SCALE

CITY OF BOX ELDER  
STANDARD DETAIL  
DROP INLET-CONC.-TYPE C-4X5-2



DETAIL #RD018

REVISED 01/2020

DETAIL RD019-DROP INLET-CONCRETE-TYPE S (4X6)-1

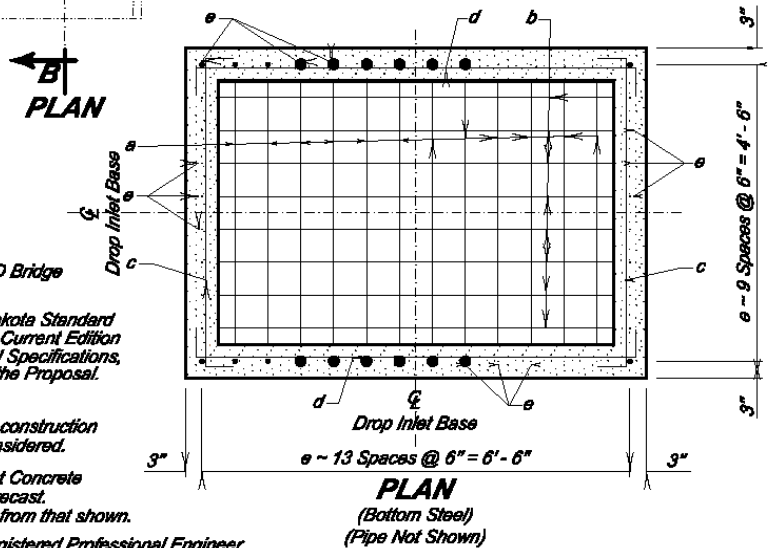
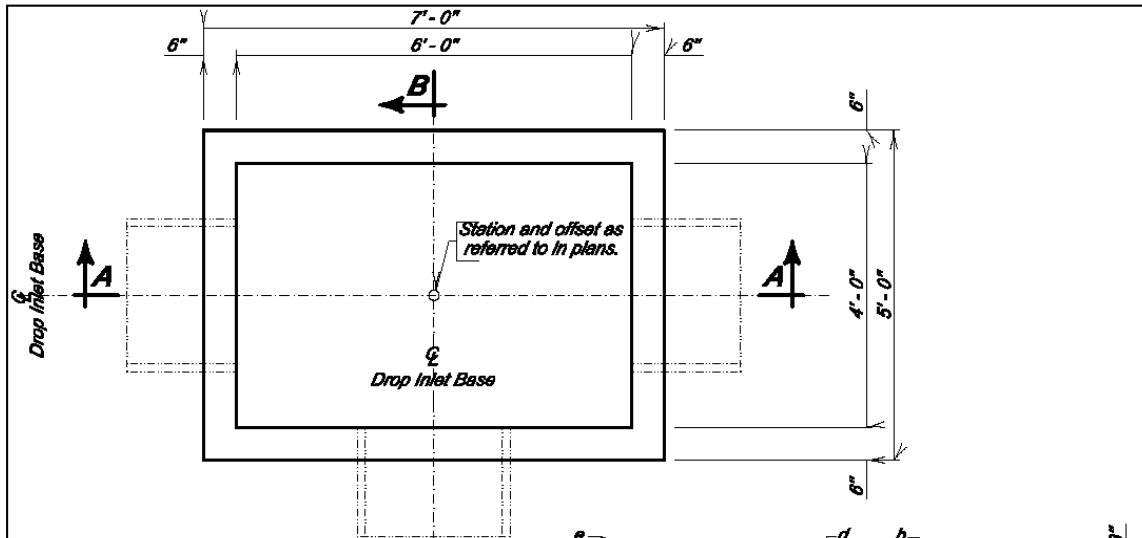

**SPECIFICATIONS:**

1. Design Specifications: AASHTO LRFD Bridge Design Specifications current edition.
2. Construction Specifications: South Dakota Standard Specifications for Roads and Bridges, Current Edition and required Provisions, Supplemental Specifications, and Special Provisions as included in the Proposal.

**GENERAL NOTES:**

1. Design Live Load: HL-93 loading. No construction loading in excess of legal load was considered.
2. Base is intended for use with a Precast Concrete Type S Drop Inlet Lid. Base may be precast. If precast base used, and details differ from that shown.
3. Design shall be by a South Dakota Registered Professional Engineer.
- \* 4. Reduce total quantities of concrete by the amount of concrete displaced by the pipe. The total quantity of concrete shall be computed to the nearest hundredth of a cubic yard. The total quantity of reinforcing steel shall be computed to the nearest pound.
5. Inlets shown may be modified by the addition or omission of connecting pipes as shown on the layouts. Connecting pipes shall not enter the inlet through the corners.
6. Maximum R.C.P. diameter shall not exceed 36 inches (30 inches for R.C. Arch) on the 4-foot wide side and shall not exceed 54 inches (48 inches for R.C. Arch) on the 6-foot wide side of the Drop Inlet.
7. Reinforcing steel shall conform to ASTM A615 Grade 60. Cut and bend reinforcing steel as required to place pipe(s) through the inlet wall.
8. Use 1 inch clear cover on all reinforcing steel unless otherwise noted.
9. The dimension of H is in feet. Maximum H is 8 feet.

**DROP INLET-CONCRETE-TYPE S (4'X6')**  
NOT TO SCALE

<p>CITY OF BOX ELDER</p> <p>STANDARD DETAIL</p> <p>DROP INLET-CONC.-TYPE S-4X6-1</p>
--



DETAIL #RD019

REVISED 01/2020



DETAIL RD020-DROP INLET-CONCRETE-TYPE S (4X6)-2

REINFORCING SCHEDULE				
Mk.	No.	Size	Length	Type
a	14	5	9'-6"	17
b	10	5	11'-6"	17
c	2H	4	5'-6"	17
d	2H	4	7'-6"	17
e	44	4	H-2"	Str.

  

Bending Details	
a	4'-10"
b	6'-10"
c	4'-8"
d	6'-8"

NOTE:  
All dimensions are out to out of bars

PIPE DISPLACEMENT REDUCTIONS		
Diameter (Inches)	Wall T (Inches)	Class M6 Concrete (Cu. Yd.)
12	2	0.03
15	2 1/4	0.04
18	2 1/2	0.05
24	3	0.08
30	3 1/2	0.14
36	4	0.20
42	4 1/2	0.26
48	5	0.34
54	5 1/2	0.43
<b>R.C.P.</b>		
18	2 1/2	0.05
24	3 1/2	0.09
30	4	0.14
36	4 1/2	0.19
42	4 1/2	0.24
48	5	0.32
<b>R.C. ARCH</b>		

ESTIMATED QUANTITIES			
ITEM	UNIT	CONSTANT QUANTITY	VARIABLE QUANTITY
Class M6 Concrete	Cu. Yd.	0.97	0.41H
Reinforcing Steel	Lb.	253.77	46.76H

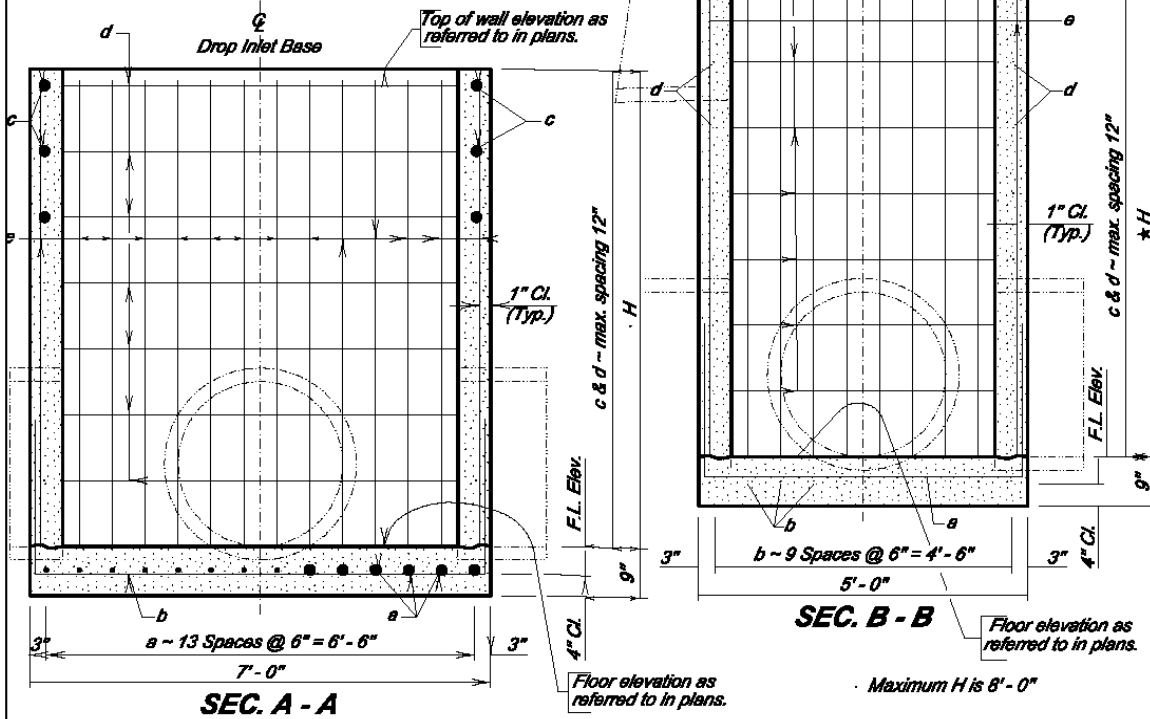

DROP INLET-CONCRETE-TYPE S (4'X6')  
NOT TO SCALE

CITY OF BOX ELDER  
STANDARD DETAIL  
DROP INLET-CONC.-TYPE S-4X6-2



DETAIL #RD020

REVISED: 01/2020

DETAIL RD021-DROP INLET-CONCRETE-TYPE S (4X6)-3

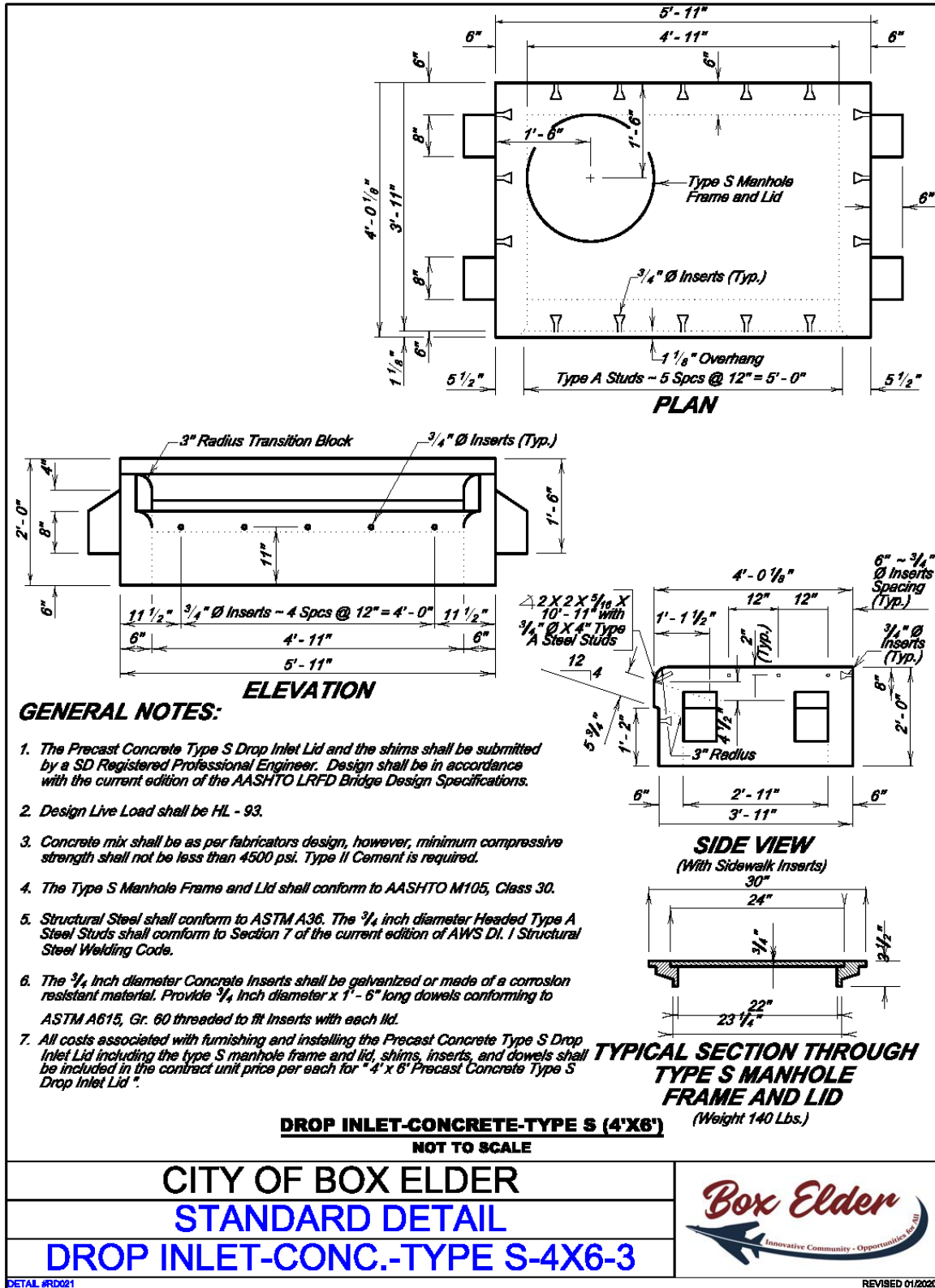

DETAIL RD022-DROP INLET-CONCRETE-TYPE S (4X11)-1

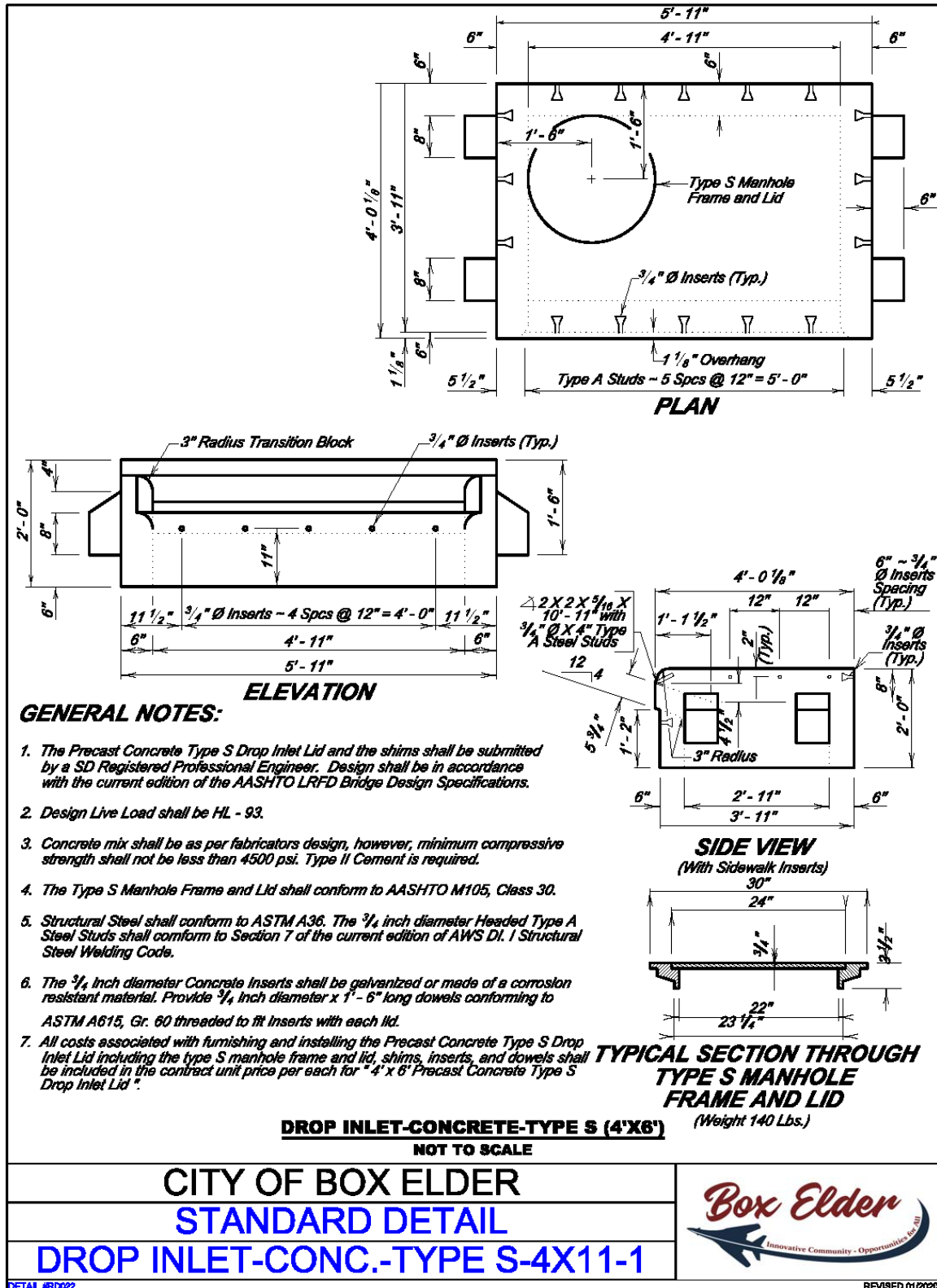

DETAIL RD023-DROP INLET-CONCRETE-TYPE S (4X11)-2

<b>PIPE DISPLACEMENT REDUCTIONS</b>			<b>REINFORCING SCHEDULE</b>						
Diameter (Inches)	Wall T (Inches)	Class M6 Concrete (Cu. Yd.)	Mk.	No.	Size	Length	Type	Bending Details	
12	2	0.03	a	24	5	9'-6"	17	d	11'-8"
15	2 1/4	0.04	b	10	5	16'-6"	17	c	4'-8"
18	2 1/2	0.05	c	2H	4	5'-6"	17	b	11'-10"
24	3	0.09	d	2H	4	12'-6"	17	a	4'-10"
30	3 1/2	0.14	e	64	4	H-2"	Str.		
36	4	0.20							
42	4 1/2	0.26							
48	5	0.34							
54	5 1/2	0.43							
60	6	0.52							
18	2 1/2	0.05							
24	3 1/2	0.09							
30	4	0.14							
38	4 1/2	0.19							
42	4 1/2	0.24							
48	5	0.32							
54	5 1/2	0.39							
60	6	0.49							
72	7	0.70							
84	8	0.93							

**ESTIMATED QUANTITIES**

ITEM	UNIT	CONSTANT QUANTITY	VARIABLE QUANTITY
✱ Class M6 Concrete	Cu. Yd.	1.67	0.59H
Reinforcing Steel	Lb.	402.77	66.80H

**NOTE:**  
All dimensions are out to out of bars.

Type 17

**R.C.P.**

12	2	0.03
15	2 1/4	0.04
18	2 1/2	0.05
24	3	0.09
30	3 1/2	0.14
36	4	0.20
42	4 1/2	0.26
48	5	0.34
54	5 1/2	0.43
60	6	0.52

**R.C. ARCH**

18	2 1/2	0.05
24	3 1/2	0.09
30	4	0.14
38	4 1/2	0.19
42	4 1/2	0.24
48	5	0.32
54	5 1/2	0.39
60	6	0.49
72	7	0.70
84	8	0.93

**SEC. B - B**

**ESTIMATED QUANTITIES**

ITEM	UNIT	CONSTANT QUANTITY	VARIABLE QUANTITY
✱ Class M6 Concrete	Cu. Yd.	1.67	0.59H
Reinforcing Steel	Lb.	402.77	66.80H

**SEC. A - A**

**DROP INLET-CONCRETE-TYPE S (4'X11')**

NOT TO SCALE

✱ Maximum H is 8' - 0"

**CITY OF BOX ELDER**

**STANDARD DETAIL**

**DROP INLET-CONC.-TYPE S-4X11-2**

DETAIL #RD023

REVISED 01/2020

DETAIL RD024-DROP INLET-CONCRETE-TYPE S (4X11)-3

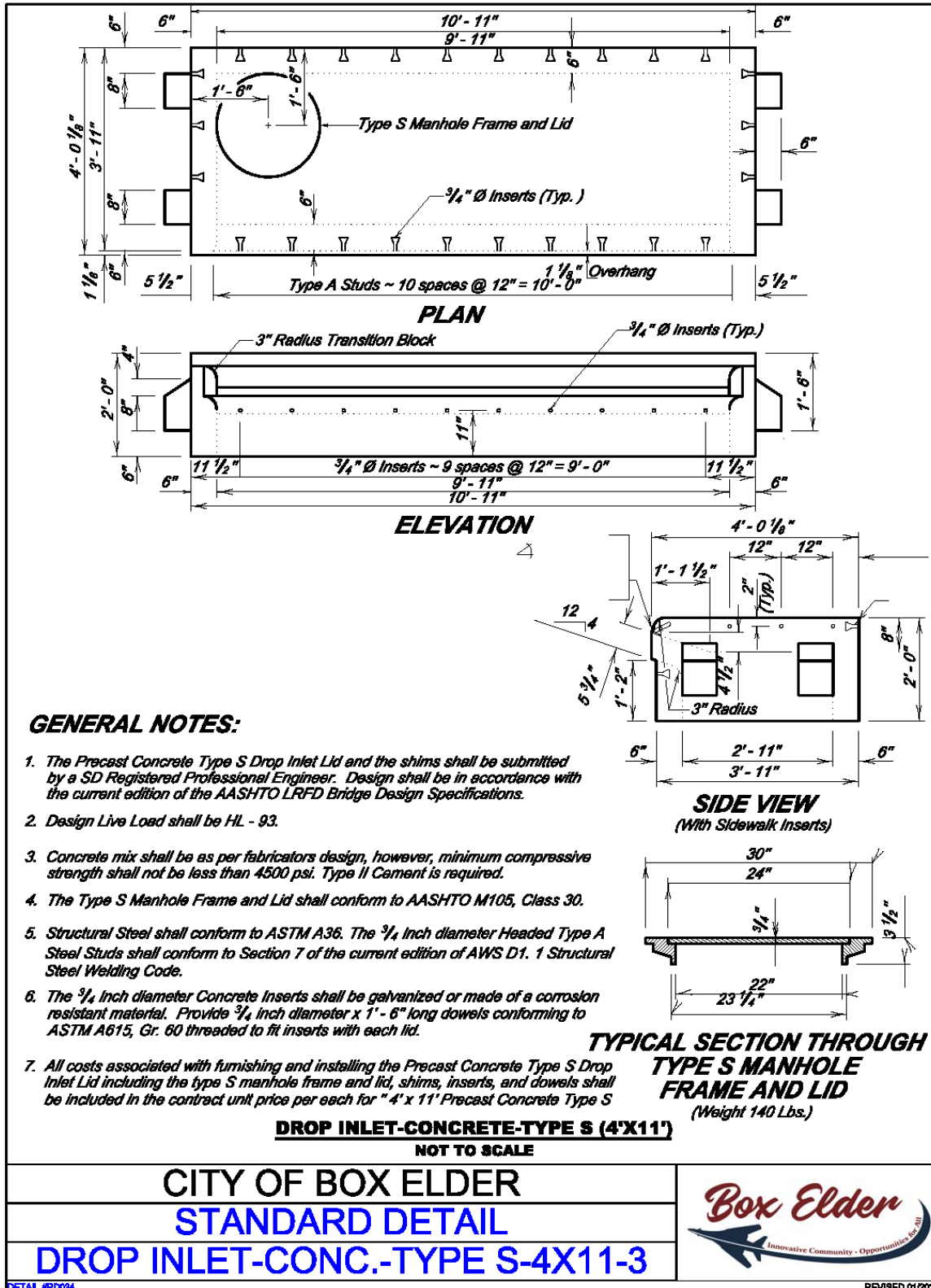

DETAIL RD025-DROP INLET-CONCRETE-TYPE S (7X11)-1

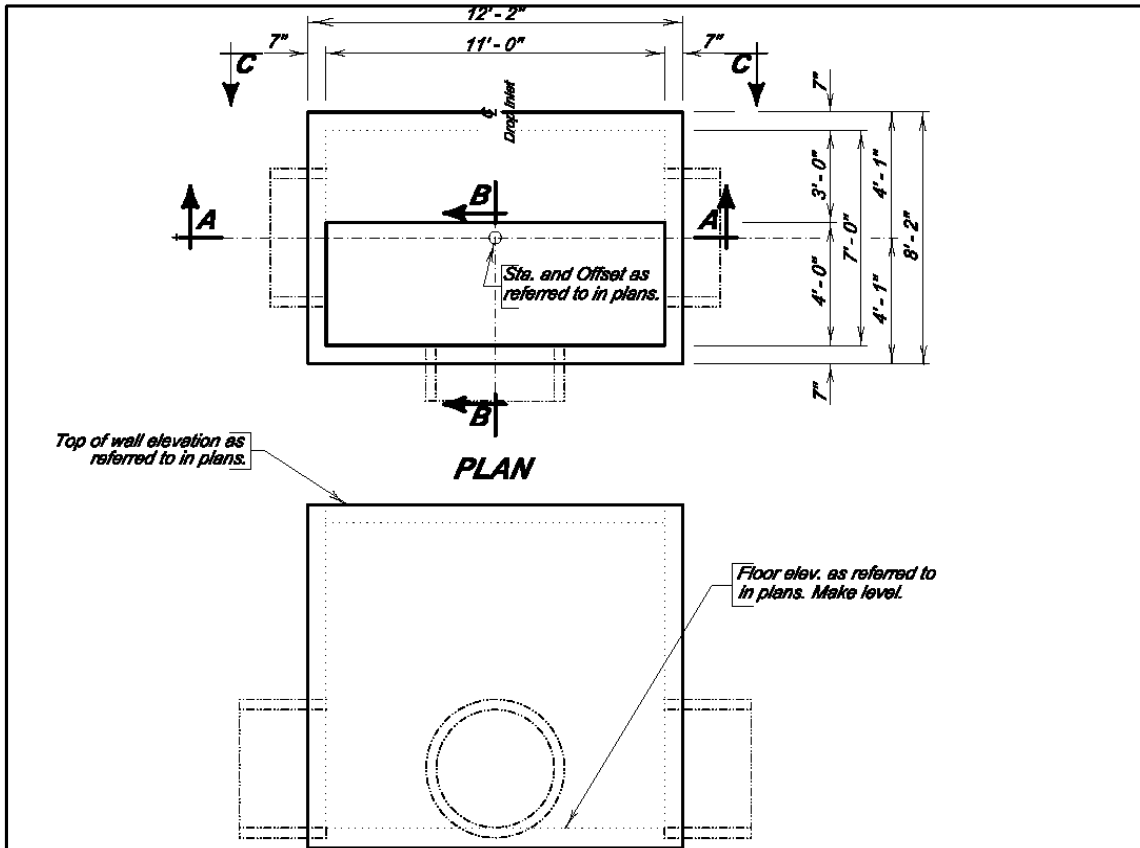

**SPECIFICATIONS:**

**ELEVATION**

1. Design Specifications: AASHTO LRFD Bridge Design Specifications, current edition.
2. Construction Specifications: South Dakota Standard Specifications for Roads and Bridges, current edition, and required Provisions, Supplemental Specifications, and Special Provisions as included in the Proposal.

**GENERAL NOTES:**

1. Design Live Load: HL-93 loading. No construction loading in excess of legal load was considered.
2. Base is intended for use with a Precast Concrete Type S Drop Inlet Lid. Base may be precast. If precast based used, and details differ from that shown, the precast base shop plans must be submitted by a SD Registered PE for approval. Design shall be in accordance with the current edition of the AASHTO LRFD Bridge Design Specifications.
3. Reduce total quantities of concrete by the amount of concrete displaced by the pipe. The total quantity of concrete shall be computed to the nearest 0.01 cubic yard. The total quantity of reinforcing steel shall be computed to the nearest pound.
4. Inlets shown may be modified by the addition or omission of connecting pipes as shown on the layouts. Connecting pipes shall not enter the inlet through the corners.
5. Maximum R.C.P. diameter shall not exceed 66 inches (54 inches for R.C. Arch) on the 7-foot wide side of the Drop Inlet.
6. Reinforcing steel shall conform to ASTM A615 Grade 60. Cut and bend reinforcing steel as required to place pipe(s) through the Inlet wall.
8. Use 1-inch clear cover on all reinforcing steel unless otherwise noted.
9. The dimension of H is in feet. Maximum H is 10 feet.

**DROP INLET-CONCRETE-TYPE S (7'X11')**

NOT TO SCALE

<p><b>CITY OF BOX ELDER</b></p> <p><b>STANDARD DETAIL</b></p> <p><b>DROP INLET-CONC.-TYPE S-7X11-1</b></p>	
DETAIL #RD025	REVISED 01/2020

DETAIL RD026-DROP INLET-CONCRETE-TYPE S (7X11)-2

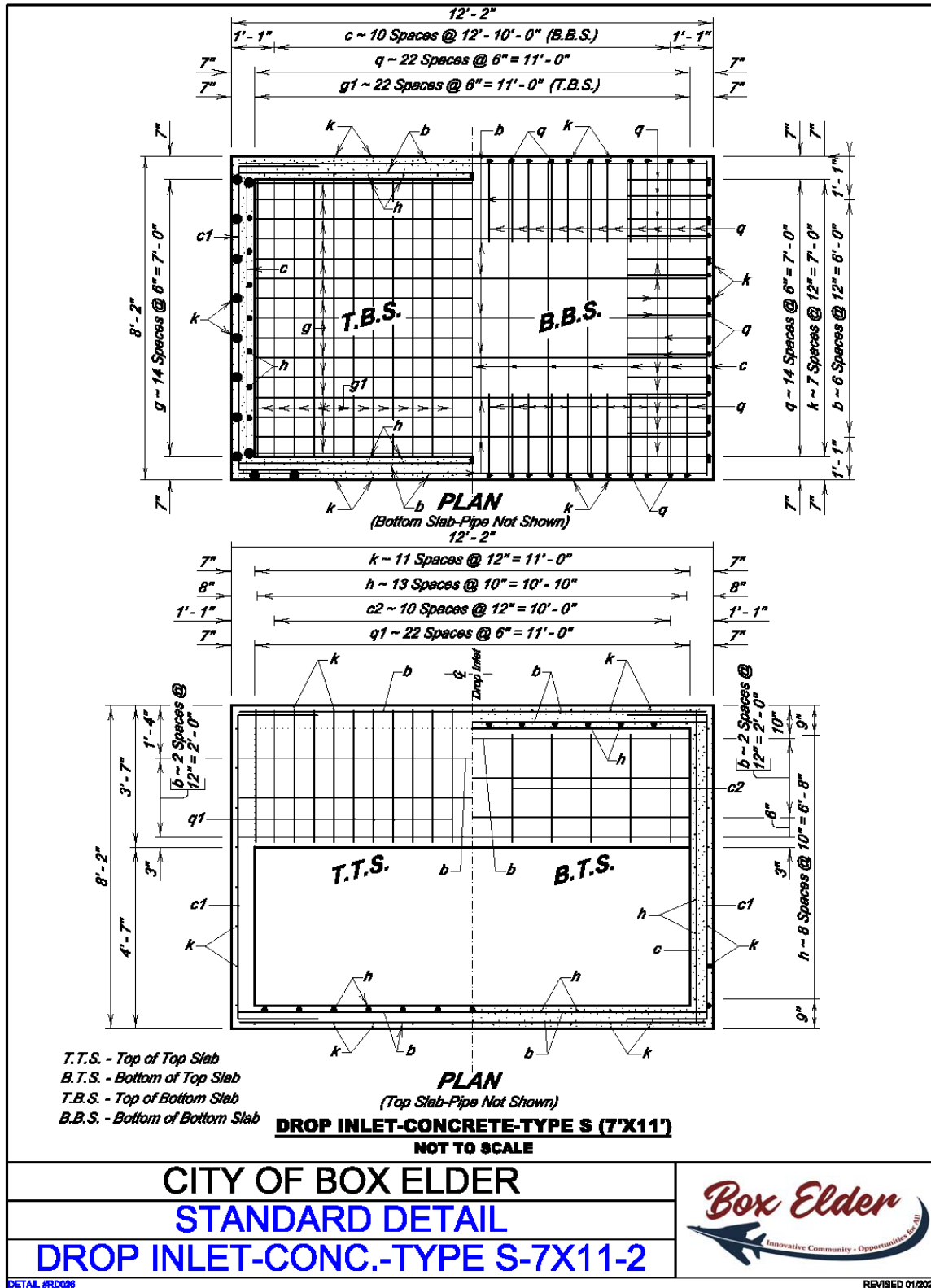

**CITY OF BOX ELDER**  
**STANDARD DETAIL**  
**DROP INLET-CONC.-TYPE S-7X11-2**



DETAIL RD027-DROP INLET-CONCRETE-TYPE S (7X11)-3

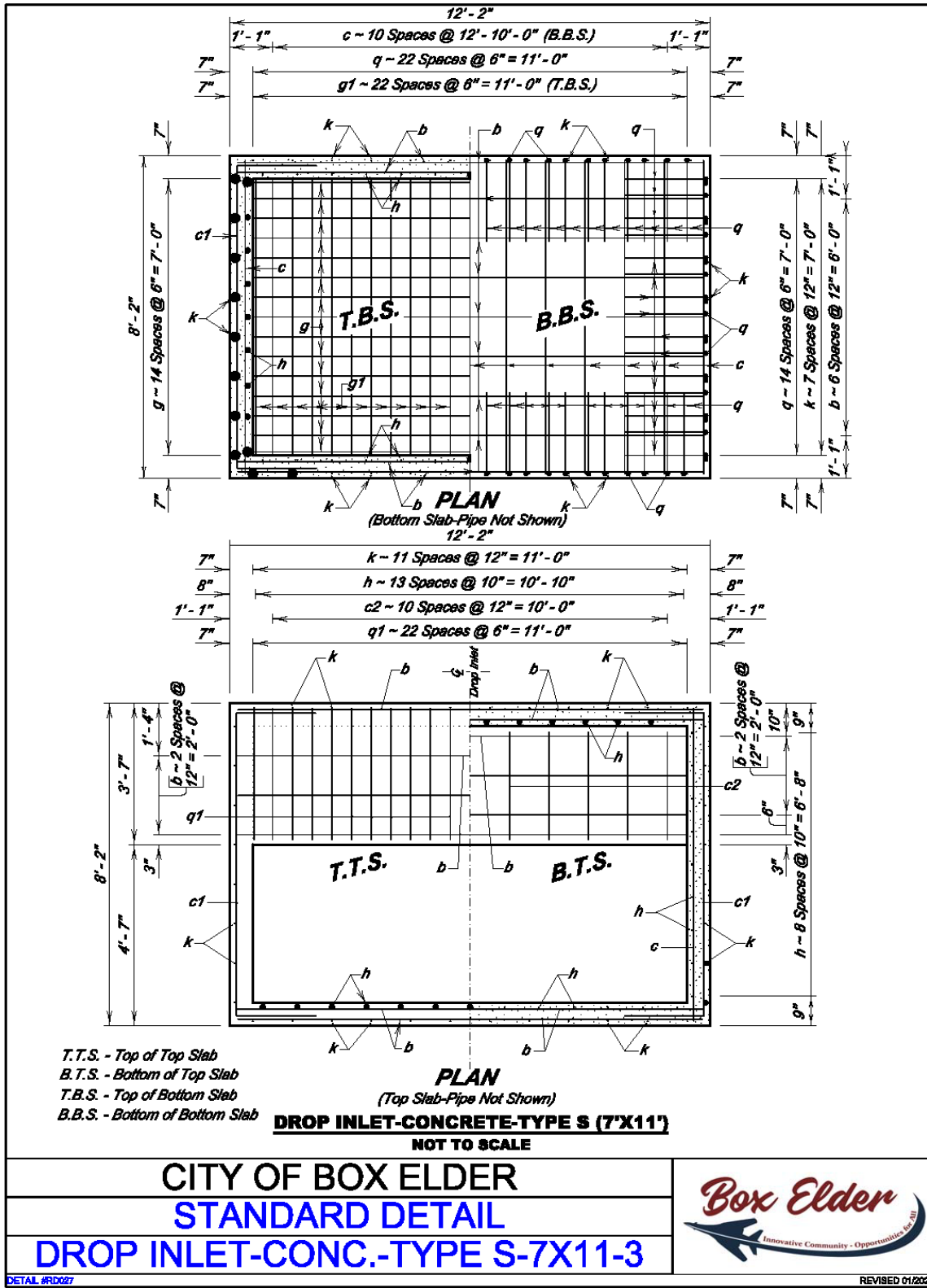



**DETAIL RD028-DROP INLET-CONCRETE-TYPE S (7X11)-4**

<b>REINFORCING SCHEDULE</b>					
Mk.	No.	Size	Length	Type	
b	19 + 4H	4	11' - 9"	Str.	
c	15 + 2H	4	7' - 9"	Str.	
c1	2 + 2H	4	11' - 10"	17	
c2	11	4	2' - 10"	Str.	
g	15	5	11' - 9"	Str.	
g1	23	5	7' - 9"	Str.	
h	46	5	H + 5"	Str.	
k	40	5	H + 5"	Str.	
q	76	5	5' - 6"	17A	
q1	23	5	6' - 8"	17A	

**NOTE:**  
All dimensions are out to out of bars

<b>ESTIMATED QUANTITIES</b>			
ITEM	UNIT	CONSTANT QUANTITY	VARIABLE QUANTITY
Class M6 Concrete	Cu. Yd.	3.65	0.83H
Reinforcing Steel	Lb.	1266	147.26H

**SEC. A - A**  
(Pipe Not Shown)

**DROP INLET-CONCRETE-TYPE S (7'X11')**  
NOT TO SCALE

<b>PIPE DISPLACEMENT REDUCTIONS</b>			
Diameter (Inches)	Wall T (Inches)	Class M6 Concrete (Cu. Yd.)	
R.C.P.	12	2	0.03
	15	2 1/4	0.04
	18	2 1/2	0.06
	24	3	0.11
	30	3 1/2	0.16
	36	4	0.23
	42	4 1/2	0.31
	48	5	0.40
	54	5 1/2	0.50
	60	6	0.61
R.C. ARCH	18	2 1/2	0.06
	24	3 1/2	0.11
	30	4	0.16
	36	4 1/2	0.22
	42	4 1/2	0.29
	48	5	0.37
	54	5 1/2	0.46
	60	6	0.57
72	7	0.82	
84	8	1.09	

**CITY OF BOX ELDER**

**STANDARD DETAIL**

**DROP INLET-CONC.-TYPE S-7X11-4**

DETAIL #RD028 REVISED 01/2020

DETAIL RD029-DROP INLET-CONCRETE-TYPE S-INSTALLATION-1

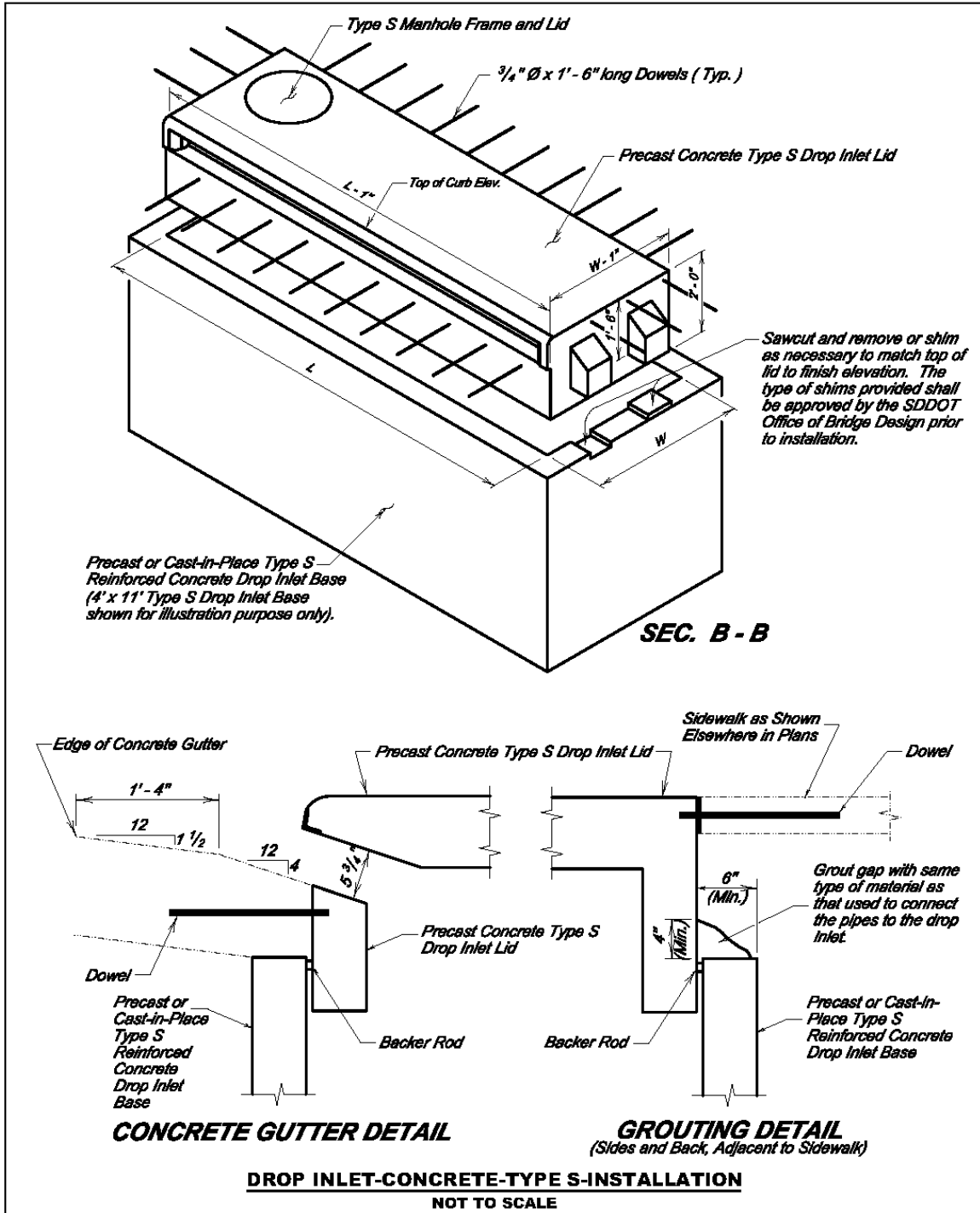

CITY OF BOX ELDER  
**STANDARD DETAIL**  
**DROP INLET-CONC.-TYPE S-INST.-1**



DETAIL #RD029

REVISED: 01/2020

DETAIL RD030-DROP INLET-CONCRETE-TYPE S-INSTALLATION-2

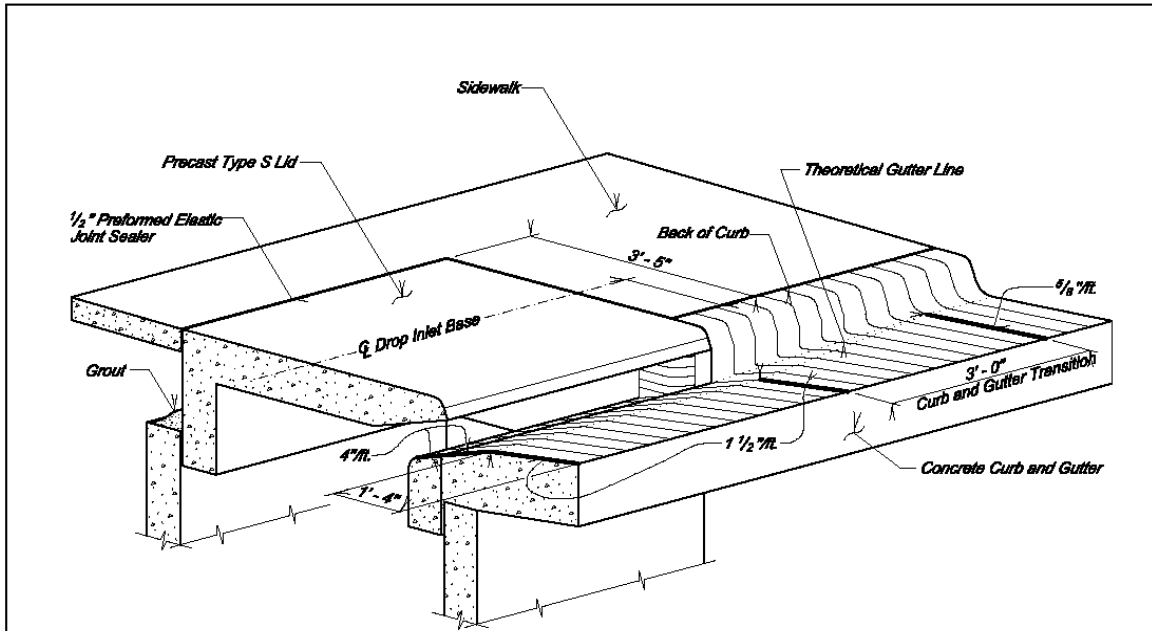

**CURB AND GUTTER  
TRANSITION DETAILS**

Drop Inlet Base Unit Size	✕ Distance
4' x 6'	1' - 5 1/2"
4' x 11'	1' - 5 1/2"
7' x 11'	2' - 11 1/2"

**GENERAL NOTES:**

1. Dowels shall be used to anchor the precast concrete Type S drop inlet lid to the concrete gutter. If there is sidewalk adjacent dowels shall be used to anchor the precast concrete Type S drop inlet lid to the sidewalk. If there is sidewalk adjacent to the drop inlet, the precast lid shall match the finish elevations and cross slopes of the sidewalk.
2. The sidewalk shall be steel reinforced when the sidewalk adjoins the precast lid.

**DROP INLET-CONCRETE-TYPE S-INSTALLATION  
NOT TO SCALE**

CITY OF BOX ELDER
STANDARD DETAIL
DROP INLET-CONC.-TYPE S-INST.-2



DETAIL #RD030

REVISED 01/2020

## DETAIL RD031-DROP INLET-CONCRETE-TYPE B-INSTALLATION

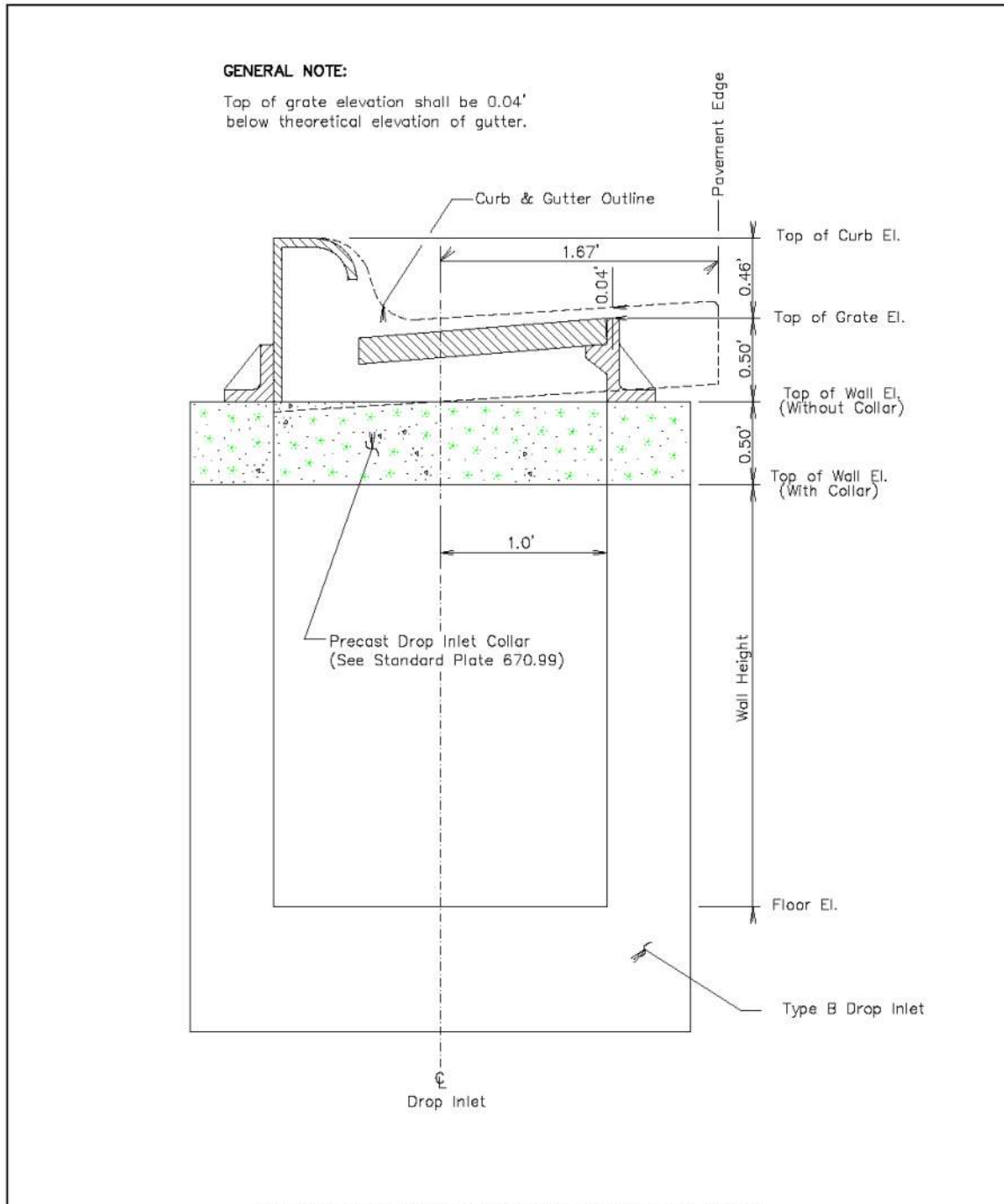

**DROP INLET-CONCRETE-TYPE B-INSTALLATION**  
NOT TO SCALE

CITY OF BOX ELDER
STANDARD DETAIL
DROP INLET-CONC.-TYPE B-INST.



DETAIL RD031

REVISED 01/2020

**DETAIL RD032-DROP INLET-CONCRETE-TYPE B-FRAME AND GRATE ASSEMBLY**

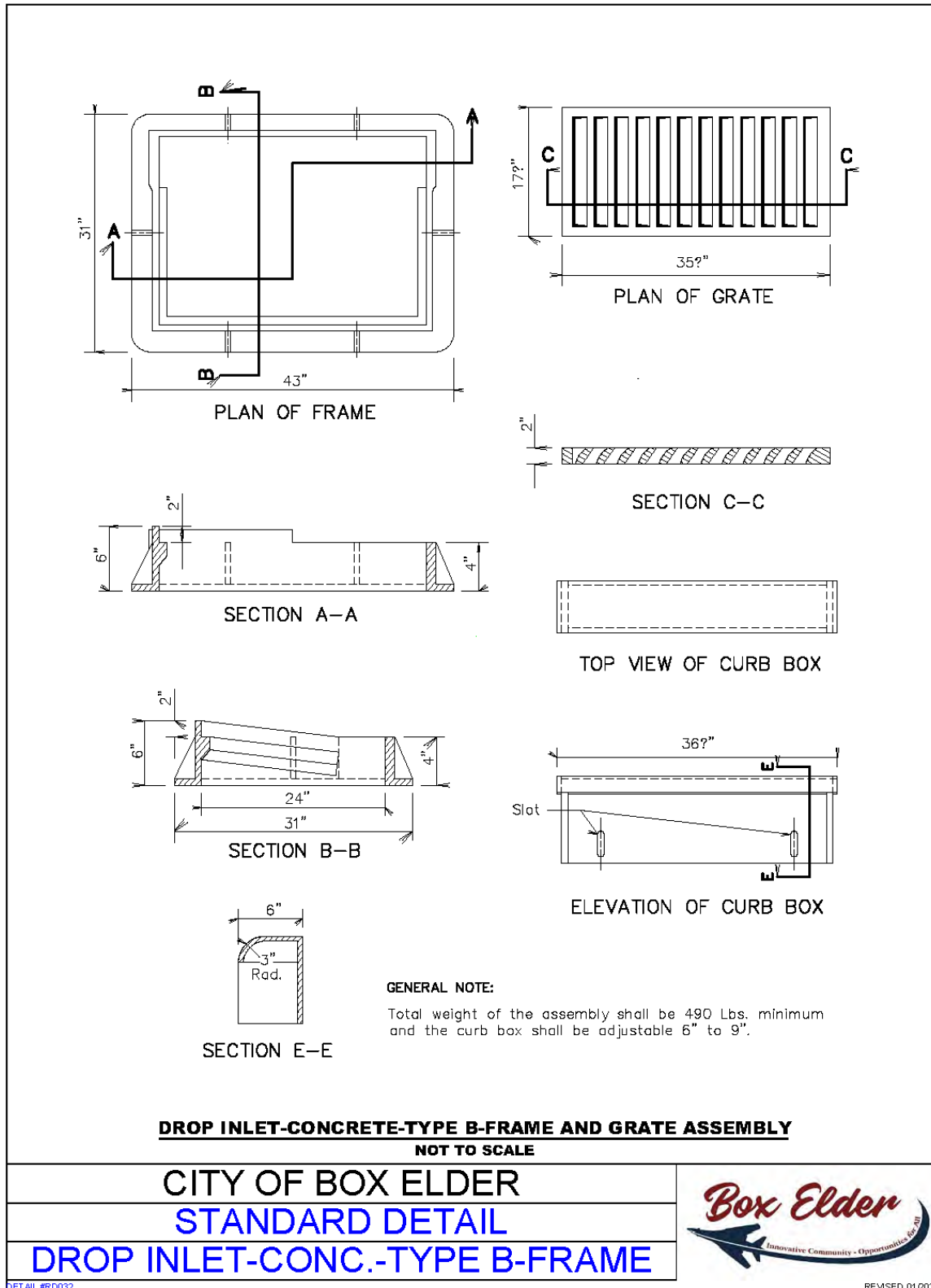

**CITY OF BOX ELDER**  
**STANDARD DETAIL**  
**DROP INLET-CONC.-TYPE B-FRAME**



**DETAIL RD033-DROP INLET-CONCRETE-TYPE C-FRAME AND GRATE ASSEMBLY**

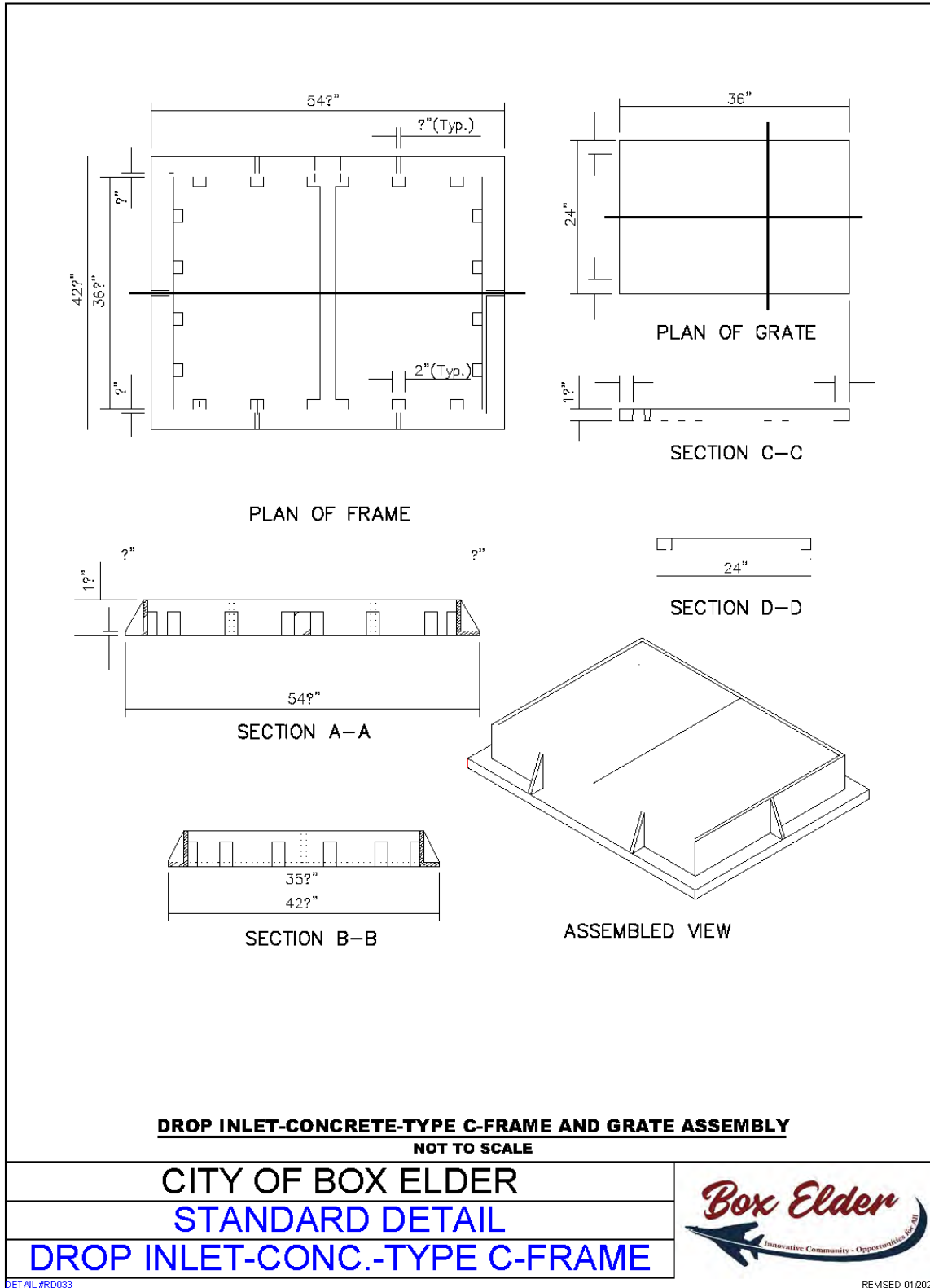

**DETAIL RD034-DROP INLET-CONCRETE-TYPE E-FRAME AND GRATE ASSEMBLY**

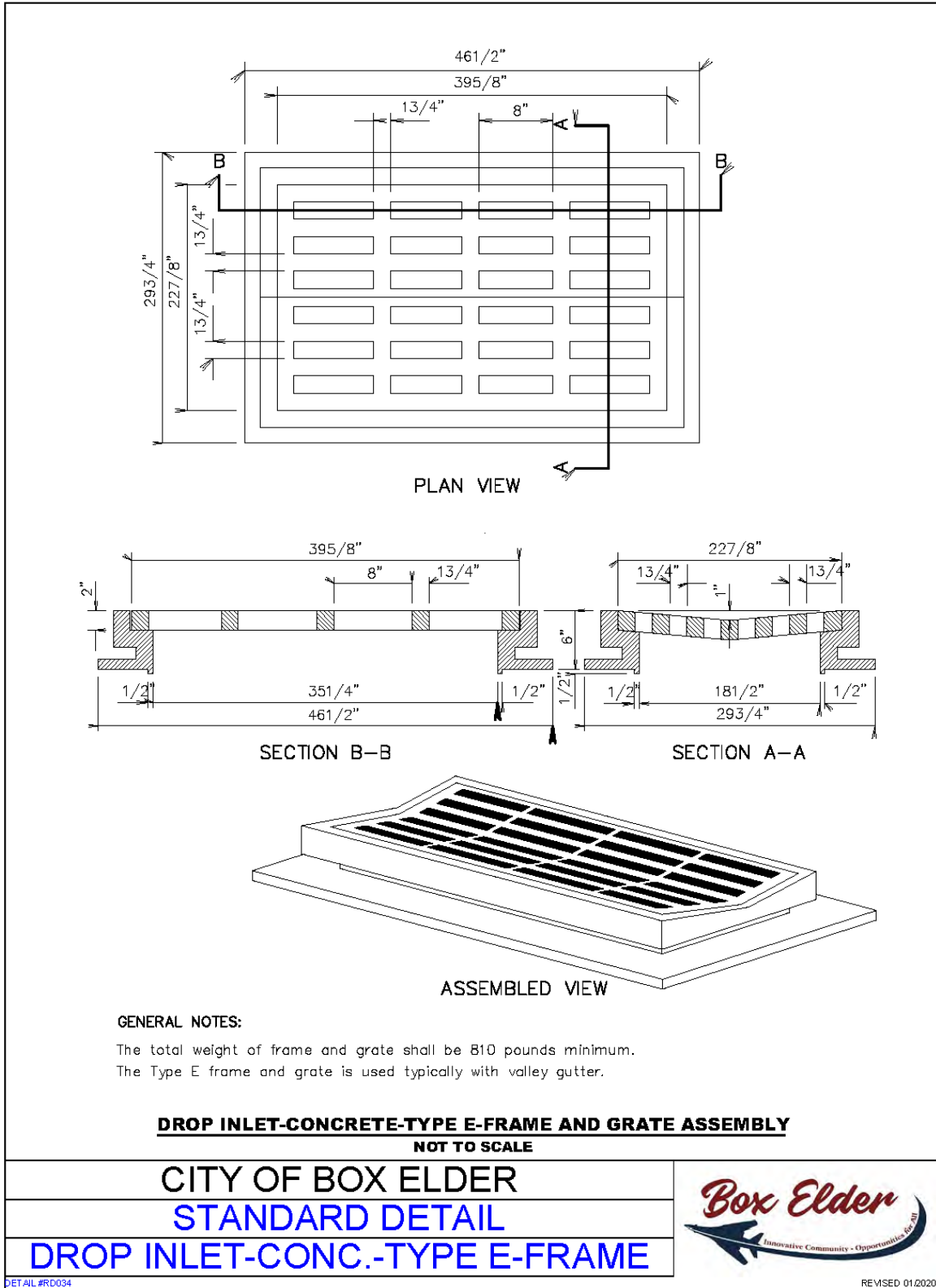

# DETAIL RD040-DROP INLET-CONCRETE-PERMANENT COVERS-1

<b>INFORMATIONAL QUANTITIES</b>			
<i>ITEM</i>	<i>Class M6 Concrete</i>	<i>Reinforcing Steel</i>	<i>Install Dowel in Concrete</i>
<b>DROP INLET COVER SIZE</b>	<i>Cu. Yd.</i>	<i>Lb.</i>	<i>Each</i>
<i>4'-0" x 11'-0"</i>	<i>1.1</i>	<i>116</i>	<i>12</i>
<i>5'-6" x 11'-0"</i>	<i>1.5</i>	<i>153</i>	<i>12</i>
<i>7'-0" x 11'-0"</i>	<i>1.9</i>	<i>218</i>	<i>12</i>

\* Quantity of #1 Dowel Bars is not included in Reinforcing Steel.

### **SPECIFICATIONS**

*Design Specifications: AASHTO LRFD Bridge Design Specifications, current edition.*

*Construction Specifications: South Dakota Standard Specifications for Roads and Bridges, Current Edition and required Provisions, Supplemental Specifications, and Special Provisions as included in the Proposal.*

### **GENERAL NOTES**

*Design Live Load: HL-93. No construction loading in excess of legal load was considered.*

*Drop inlet covers may be precast. If precast drop inlet cover details differ from this standard plate, submit a checked design done by a SD registered P.E. with shop plans to the Engineer for approval. If precast, top side of lid shall be marked.*

*Use 1 1/2 inch clear cover on all reinforcing steel except as shown.*

*All exposed edges shall be chamfered 1/4 inch.*

*Maximum fill over drop inlet cover shall be 3 feet, including surfacing.*

*Contractor shall break out drop inlet walls as necessary for the drop inlet cover to fit below roadway surfacing.*

*Apply a thin layer of grout between drop inlet and cover to ensure uniform bearing. Grout shall conform to the Specifications.*

*All costs involved in furnishing and installing the drop inlet cover including the epoxy resin and dowels shall be incidental to the contract unit price per Each for "4' x 11' Drop Inlet Cover", "5.6' x 11' Drop Inlet Cover, or "7' x 11' Drop Inlet Cover".*

### **INSTALLING DOWELS IN CONCRETE**

*Holes drilled in the existing concrete shall be true and normal or as shown in the plans. Care shall be taken not to damage the existing reinforcing steel. It is very likely that some of the existing reinforcing steel shown in the original construction plans may have been placed out of position during original construction. In spite of this precaution, the Contractor can still expect to encounter and have to drill through reinforcing steel or shift the dowel spacing as approved by the Engineer to miss the existing reinforcing steel.*

*The epoxy resin mixture shall be of a type for bonding steel to hardened concrete and shall conform to AASHTO M235 Type IV, Grade 3 (Equivalent to ASTM C881, Type IV, Grade 3).*

*The diameter of the drilled holes shall not be less than 1/8 inch greater, nor more than 1/8 inch greater than the diameter of the dowels or as per the Manufacturer's recommendations. Use compressed air or other techniques to ensure that the hole is free of any loose material before epoxy resin is applied.*

*Mix epoxy resin as recommended by the Manufacturer and apply by an injection method as approved by the Engineer. Beginning at the bottom of the drilled holes, fill the holes 1/2 to 1/2 full of epoxy resin. Rotate the steel bar during installation to eliminate voids and ensure complete bonding of the bar. Insertion of the bars by the dipping method will not be allowed.*

*No loads shall be applied to the epoxy grouted dowel bars until the epoxy resin has had sufficient time to cure as specified by the epoxy resin manufacturer.*

*Embed dowels 9 inches into existing concrete.*

## **DROP INLET-CONCRETE-PERMANENT COVERS (VARIOUS)**

NOT TO SCALE

**CITY OF BOX ELDER**

**STANDARD DETAIL**

**DROP INLET-CONC.-PERM. COVERS-1**



DETAIL #RD040

REVISED 01/2020



# DETAIL RD040-DROP INLET-CONCRETE-PERMANENT COVERS-2

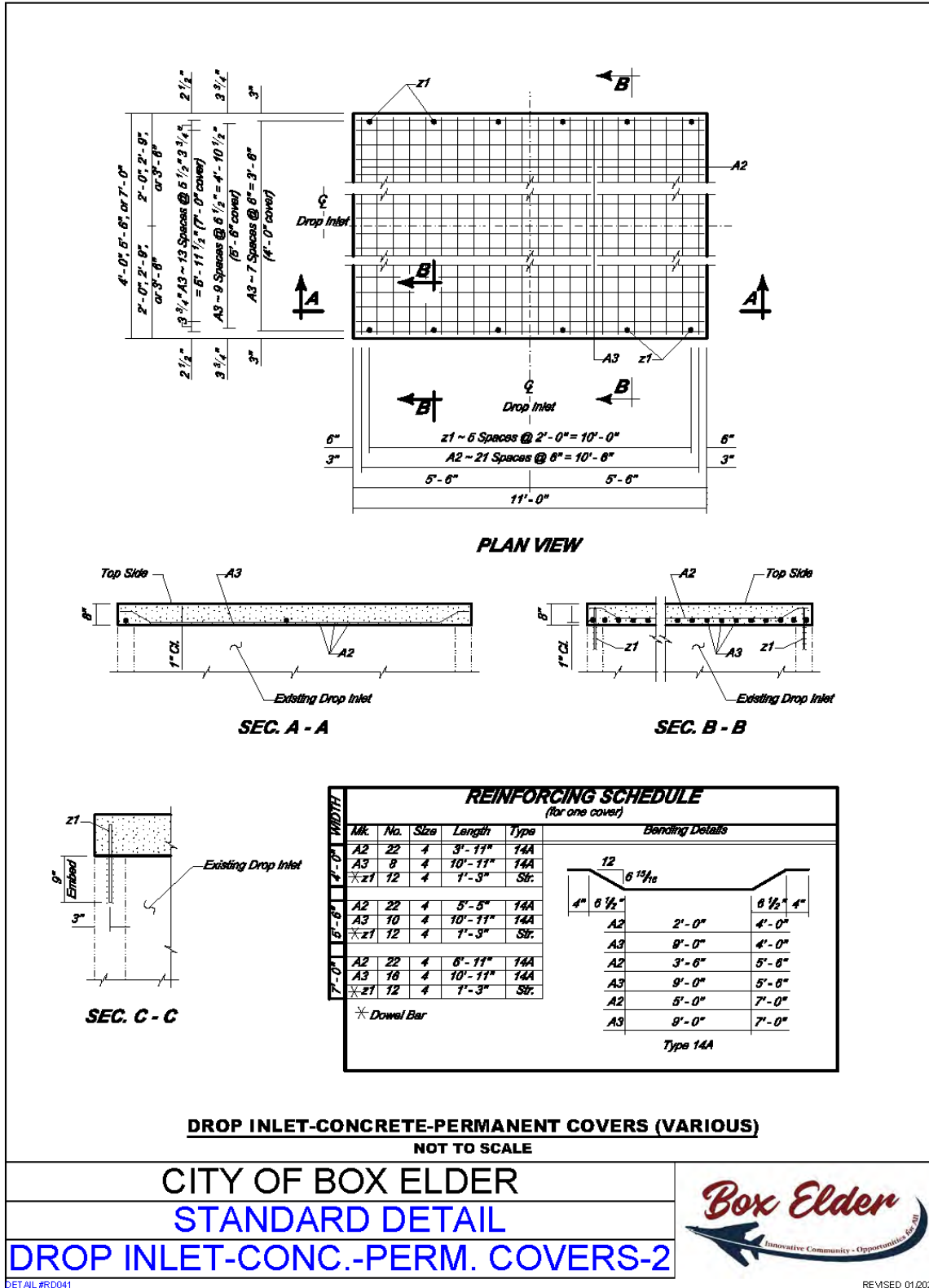

**DETAIL RD042-DROP INLET-CONCRETE-PRECAST COLLAR**

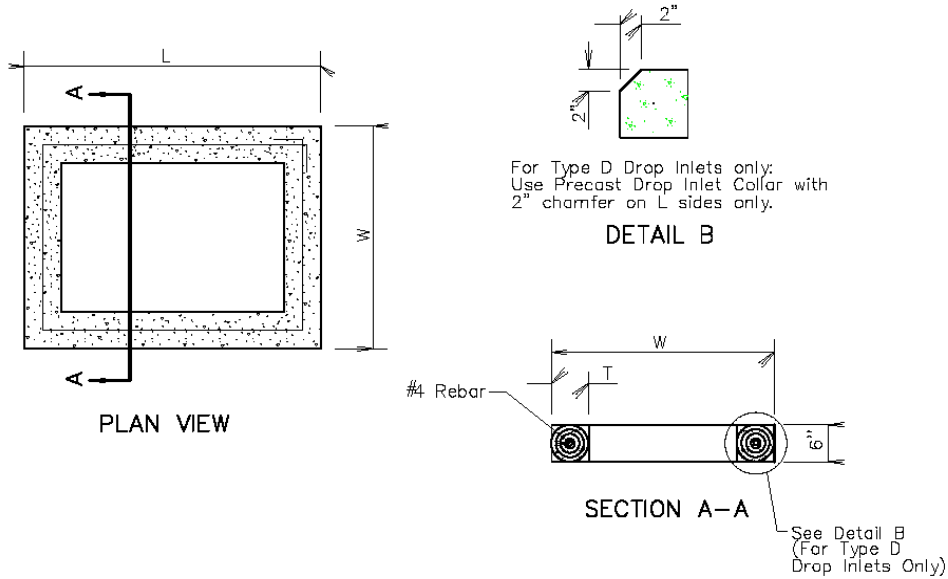

INFORMATIONAL QUANTITIES					
FRAME AND GRATE TYPE	L Ft-In	W Ft-In	T In	CLASS M6 CONCRETE CuYd	REINFORCING STEEL Lb
TYPE B	4'-0"	3'-0"	6	0.11	9
TYPE C	5'-0"	4'-0"	6	0.15	11
TYPE D	4'-0"	2'-6"	6	0.10	8

**GENERAL NOTES:**

All reinforcing steel shall conform to ASTM A615, Grade 60.  
The reinforcement bar shall lap 6 inches and shall be centered in the concrete.  
The cost of furnishing and installing Precast Drop Inlet Collars, including labor, materials, and incidentals shall be incidental to the contract unit price per Each for "Precast Drop Inlet Collar".

**DROP INLET-CONCRETE-PRECAST COLLAR**  
**NOT TO SCALE**

**CITY OF BOX ELDER**  
**STANDARD DETAIL**  
**DROP INLET-CONC.-PRECAST COLLAR**



DETAIL #RD042

REVISED 01/2020

**DETAIL RD050-DROP INLET-MANHOLE FRAME AND LID-TYPE A**

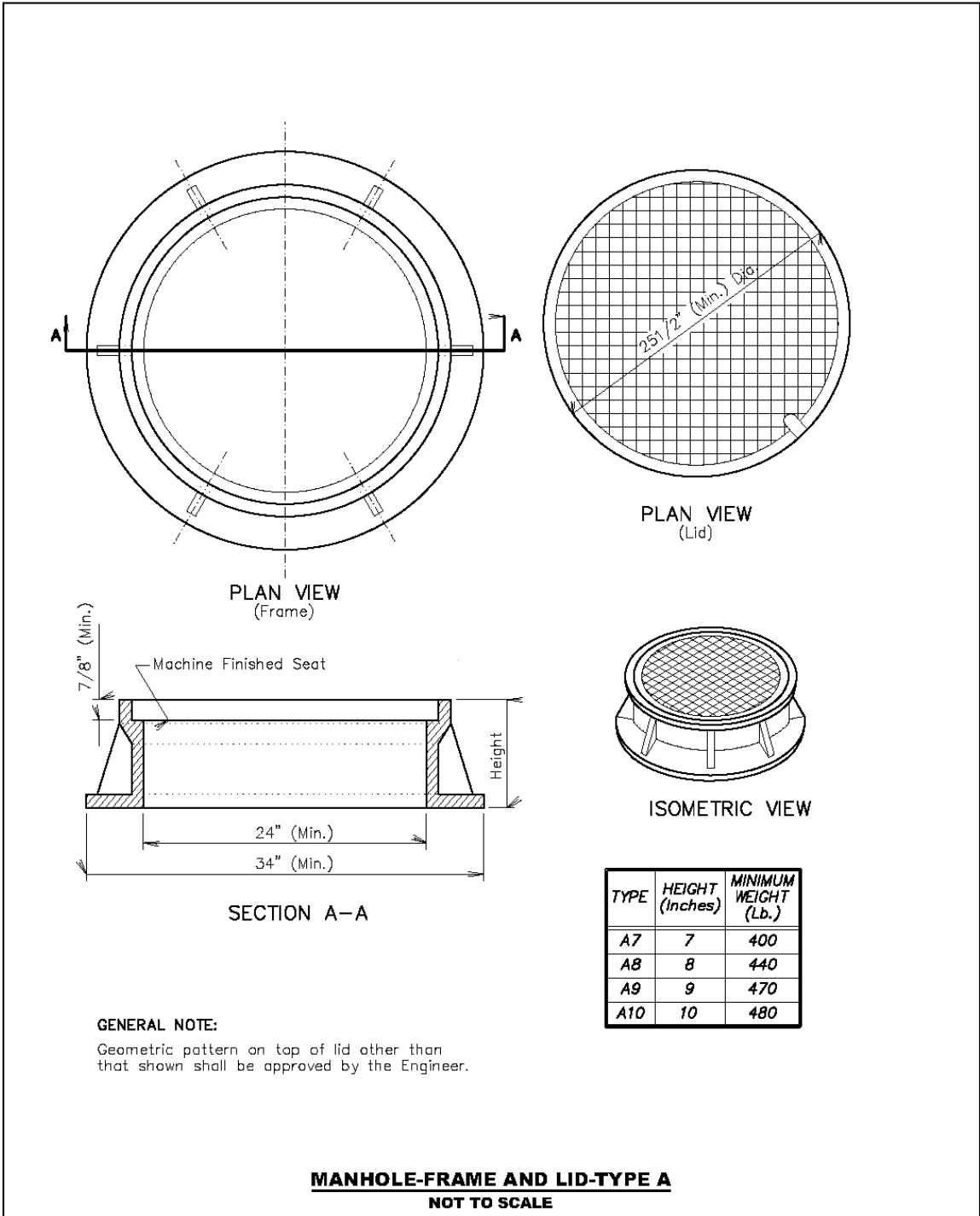

**CITY OF BOX ELDER**  
**STANDARD DETAIL**  
**MANHOLE FRAME AND LID-TYPE A**



DETAIL #RD050

REVISED 01/2020

**DETAIL RD051-DROP INLET-MANHOLE FRAME AND LID-TYPE B**

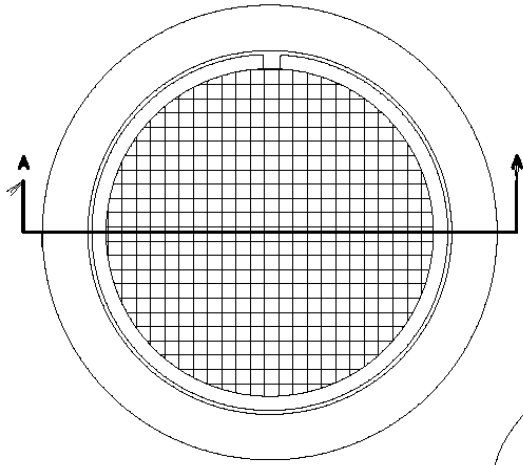

PLAN VIEW

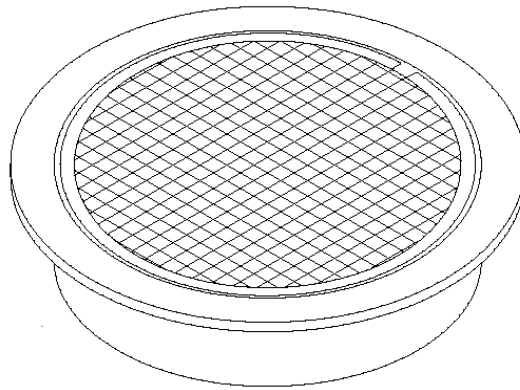

ASSEMBLED VIEW

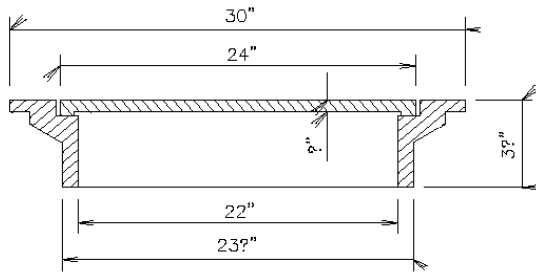

SECTION A-A

**GENERAL NOTE:**

Total weight of the frame and lid shall be 140 Lbs. minimum.

**MANHOLE-FRAME AND LID-TYPE B**

**NOT TO SCALE**

**CITY OF BOX ELDER**

**STANDARD DETAIL**

**MANHOLE FRAME AND LID-TYPE B**



DETAIL #RD051

REVISED 01/2020

## DETAIL RD060-HEADWALL-CONCRETE-UNDERDRAIN

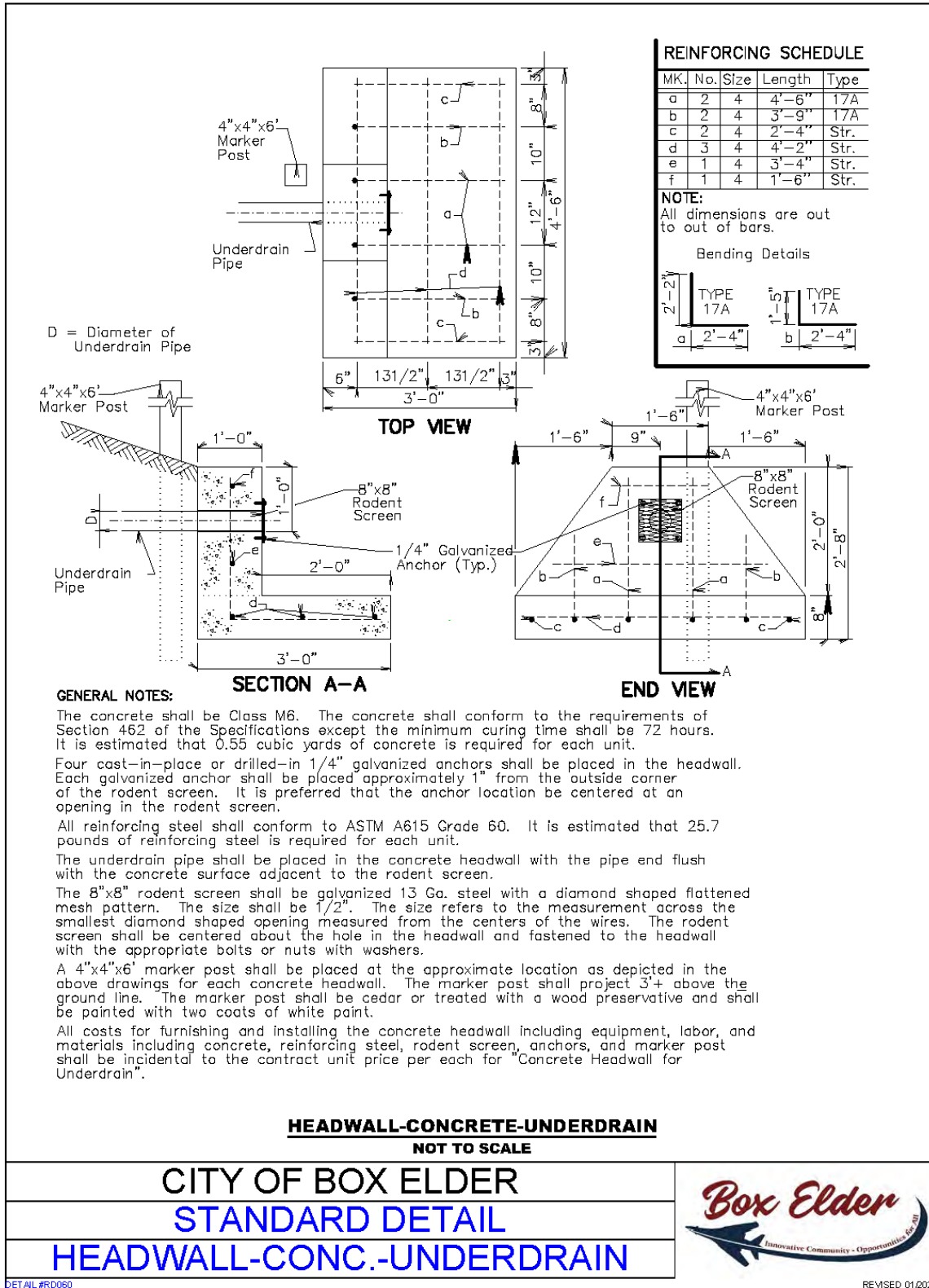

# DETAIL RE001-EROSION CONTROL-BLANKET

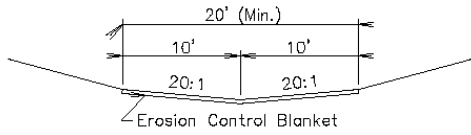

**STANDARD DITCH SECTION**

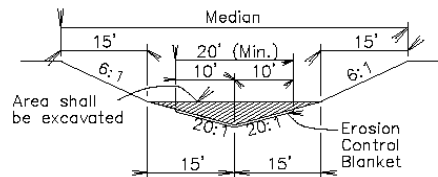

The median shall be shaped to the limits shown in this detail where the erosion control blanket will be placed.

**MEDIAN SECTION**

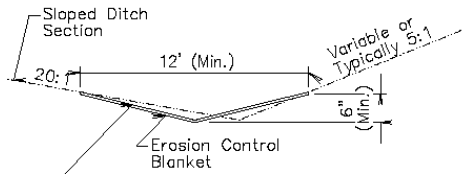

This ditch section shall be constructed when installing erosion control blanket.

**SLOPED DITCH SECTION**

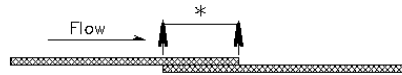

\* Use a 4" (Min.) overlap wherever two widths of erosion control blanket are applied side by side.

\* Use a 6" (Min.) overlap wherever one roll of erosion control blanket ends and another begins.

**OVERLAP DETAIL**

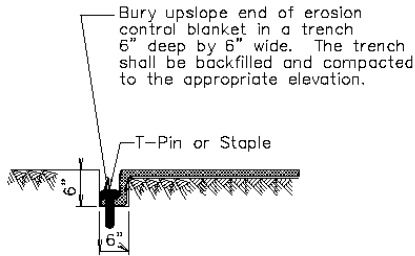

**TRENCH DETAIL**

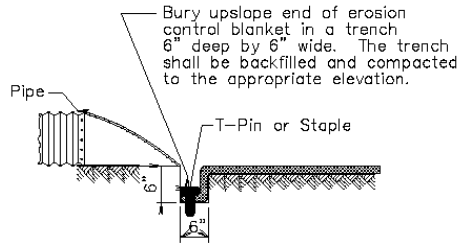

**PIPE END DETAIL**

**GENERAL NOTES:**

Prior to placement of the erosion control blanket, the areas shall be properly prepared, shaped, seeded, and fertilized.

Erosion control blanket shall be unrolled in the direction of the flow of water when placed in ditches and on slopes. The upslope end of the erosion control blanket shall be buried in a trench 6" deep by 6" wide. There shall be at least a 6" overlap wherever one roll of erosion control blanket ends and another begins, with the upslope erosion control blanket placed on top of the downslope erosion control blanket.

The erosion control blanket shall be pinned to the ground according to the manufacturer's installation recommendations.

After the placement of the erosion control blanket, the Contractor shall fine grade along all edges of the blanket to maintain a uniform slope adjacent to the blanket and level any low spots which might prevent uniform and unrestricted flow of side drainage directly onto the erosion control blanket.

All ditch sections shall be shaped when installing the erosion control blanket. All costs for shaping the ditches shall be incidental to the contract unit price per foot for "Shaping for Erosion Control Blanket".

**EROSION CONTROL-BLANKET**  
**NOT TO SCALE**

**CITY OF BOX ELDER**  
**STANDARD DETAIL**  
**EROSION CONTROL-BLANKET**



DETAIL #RE001

REVISED 01/2020

## DETAIL RE002-EROSION CONTROL-BALES

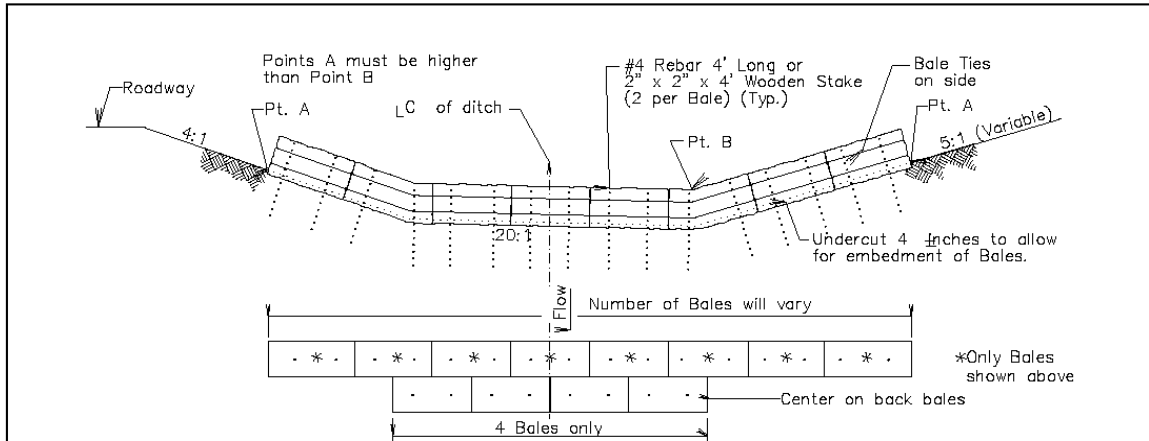

**NORMAL DITCH SECTION FOR EROSION BALE INSTALLATION**

\*\*The maximum spacing between sediment barriers should be such that the toe of the upstream sediment barrier is at the same elevation as the top of the downstream sediment barrier.

Grade	Spacing (Ft.)
2%	75
3%	50
4%	40
5%	30
6% & steeper	25

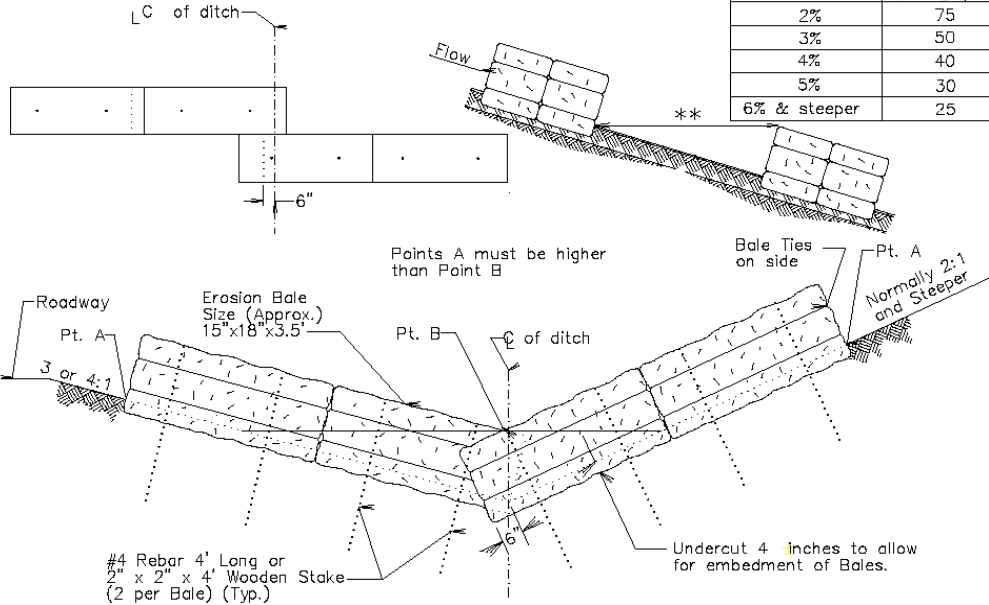

### EROSION BALE INSTALLATION

(This Ditch Section and Erosion Bale Installation Typically Used in Black Hills)

**GENERAL NOTES:**

The erosion bale sediment barrier must be entrenched and backfilled. A trench should be excavated the width of a bale and the length of the proposed sediment barrier to a minimum depth of 4 inches. After the bales are staked with rebar or wood stakes, the excavated soil must be backfilled against the sediment barrier. The sediment barrier must be extended to such a length that the bottoms of the end bales are higher in elevation than the top of the lowest middle bale.

### EROSION CONTROL-BALES

NOT TO SCALE

CITY OF BOX ELDER
STANDARD DETAIL
EROSION CONTROL-BALES

**Box Elder**  
Innovative Community - Opportunities for All

DETAIL #RE002

REVISED 01/2020

**DETAIL RE003-EROSION CONTROL-ROCK CHECK DAM**

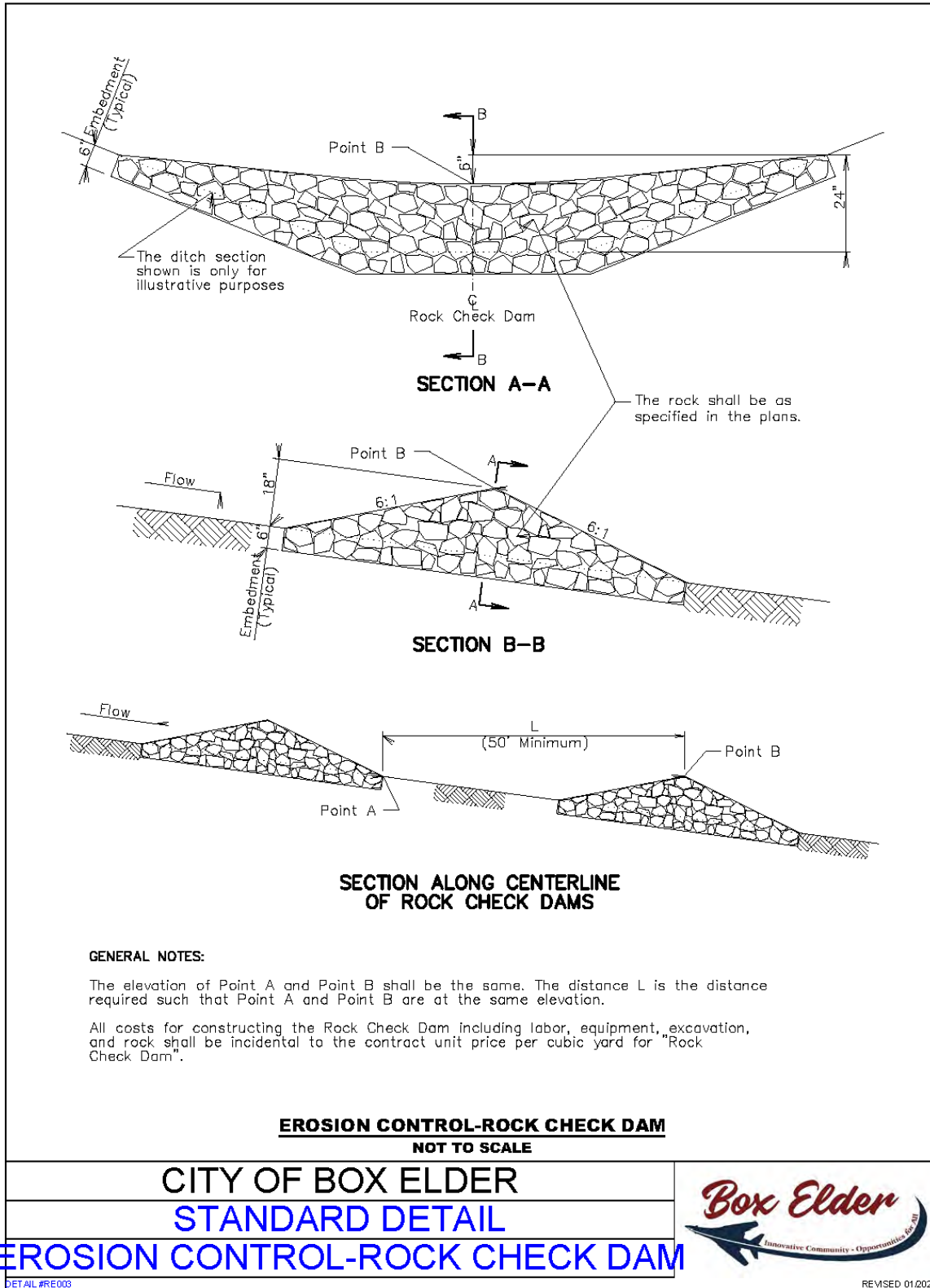



# DETAIL RE004-EROSION CONTROL-SILT FENCE-1

## MANUAL LOW FLOW SILT FENCE INSTALLATION

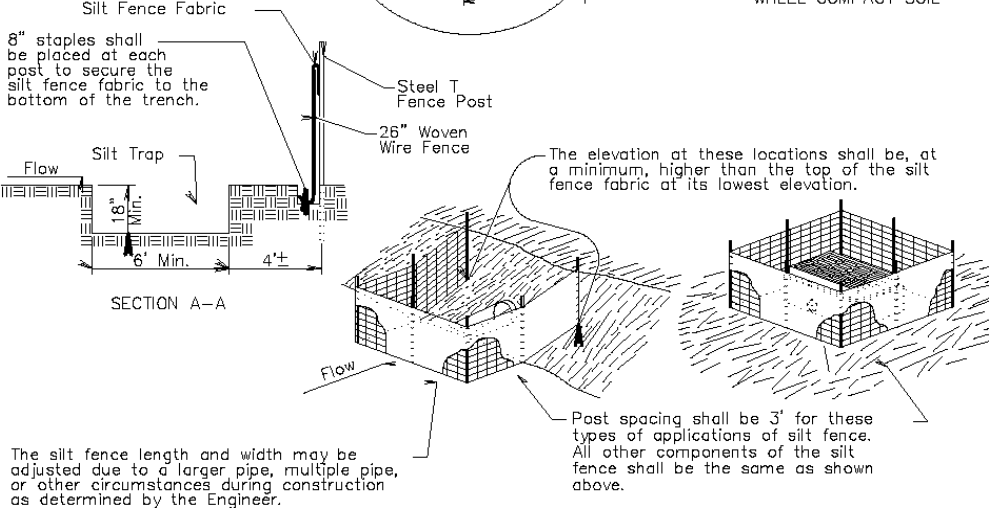
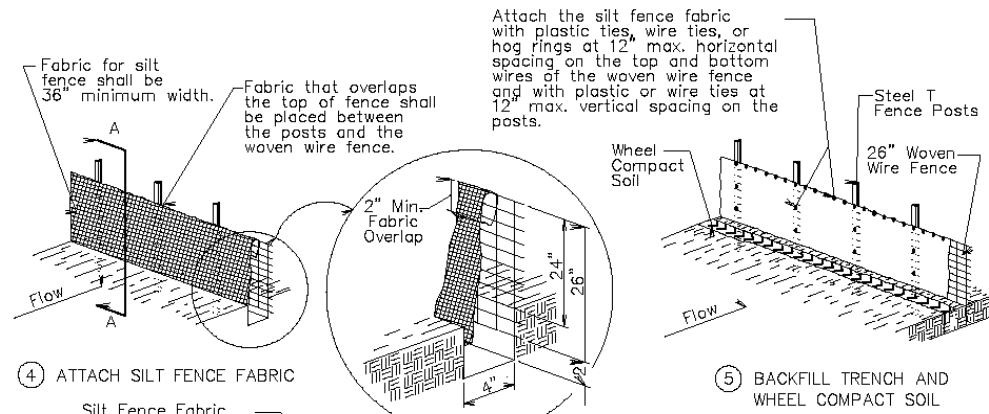
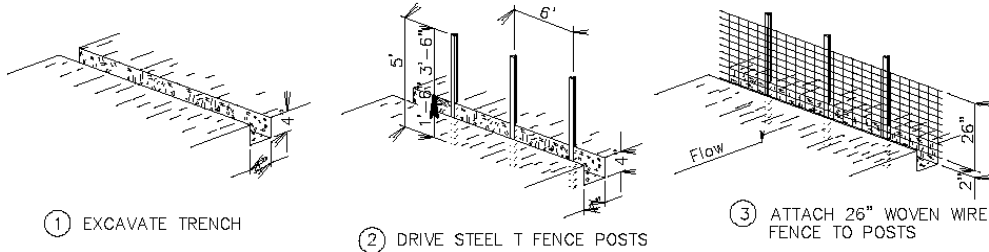

The silt fence length and width may be adjusted due to a larger pipe, multiple pipe, or other circumstances during construction as determined by the Engineer.

### EROSION CONTROL-LOW FLOW SILT FENCE AND TRAP NOT TO SCALE

CITY OF BOX ELDER  
STANDARD DETAIL  
EROSION CONTROL-SILT FENCE-1



DETAIL #RE004

REVISED 01/2020

**DETAIL RE005-EROSION CONTROL-SILT FENCE-2**

**MACHINE SLICED LOW FLOW SILT FENCE INSTALLATION**

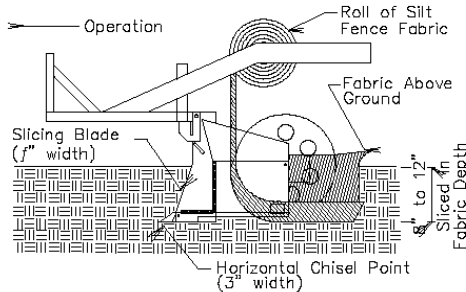

① INSTALL SILT FENCE FABRIC BY MACHINE SLICING METHOD.

Silt fence fabric shall be overlapped a minimum of 2" at top of woven wire fence.

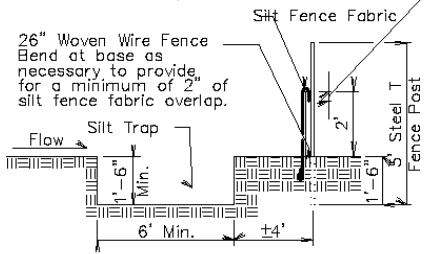

③ ATTACH 26" WOVEN WIRE FENCE TO POSTS AND ATTACH SILT FENCE FABRIC.

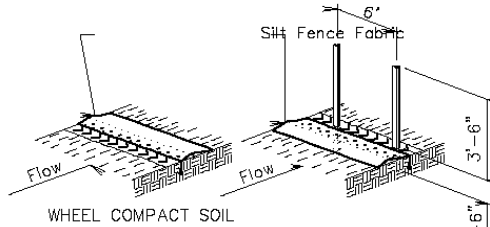

DRIVE STEEL T FENCE POSTS

② WHEEL COMPACT SOIL ABOVE SLICED IN PORTION OF FABRIC AND THEN DRIVE STEEL T FENCE POSTS.

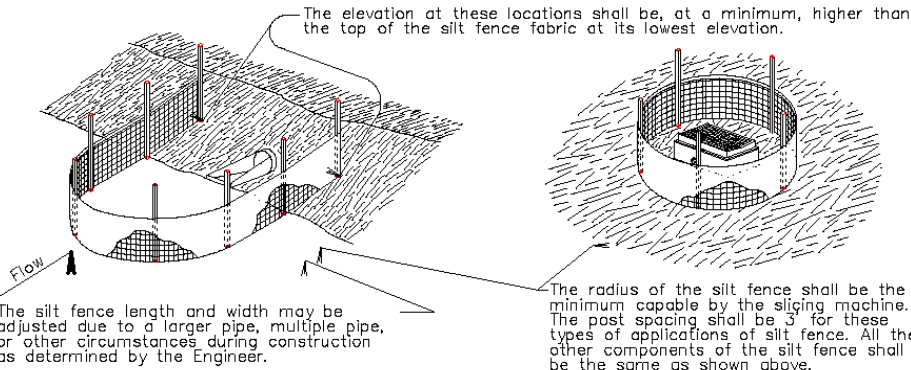
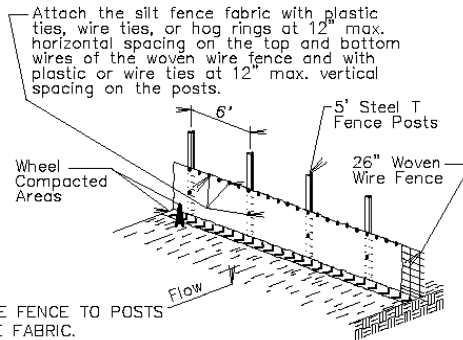

**GENERAL NOTES:**

A silt trap shall be provided when specified by a plan note. All costs for constructing the silt trap shall be incidental to the contract unit price per cubic yard for "Silt Trap".

If a trench can not be dug or the silt fence fabric can not be sliced in due to the type of earthen material (such as rock), then a row of 30 to 40 pound sandbags butted end to end shall be provided on top of the extra length of silt fence fabric to prevent underflow.

**EROSION CONTROL-LOW FLOW SILT FENCE AND TRAP**

**NOT TO SCALE**

**CITY OF BOX ELDER**  
**STANDARD DETAIL**  
**EROSION CONTROL-SILT FENCE-2**



DETAIL #RE005

REVISED 01/2020

## DETAIL RE006-EROSION CONTROL-WATTLE-1

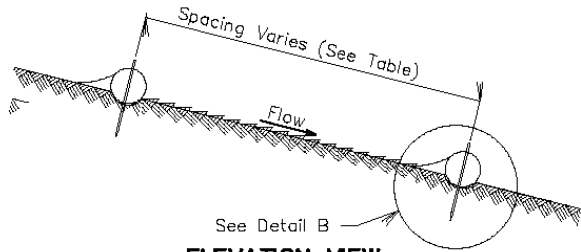

CUT OR FILL SLOPE INSTALLATION	
Slope	Spacing (Ft)
1:1	10
2:1	20
3:1	30
4:1	40

**ELEVATION VIEW  
CUT OR FILL SLOPE INSTALLATION**

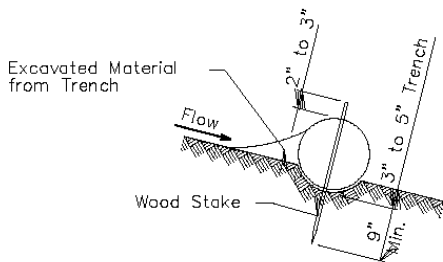

**DETAIL B  
(TYPICAL OF ALL INSTALLATIONS)**

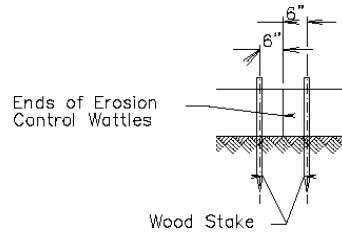

**DETAIL C**

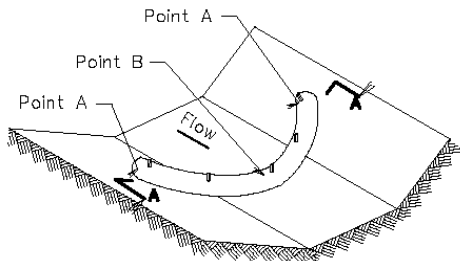

**ISOMETRIC VIEW  
DITCH INSTALLATION**

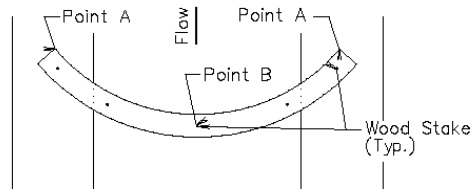

**PLAN VIEW  
DITCH INSTALLATION**

DITCH INSTALLATION	
Grade	Spacing (Ft)
2%	150
3%	100
4%	75
5%	50

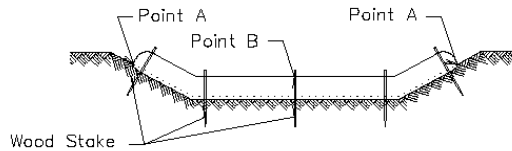

**SECTION A-A**

**EROSION CONTROL-WATTLE  
NOT TO SCALE**

**CITY OF BOX ELDER  
STANDARD DETAIL  
EROSION CONTROL-WATTLE-1**



DETAIL #RE006

REVISED 01/2020

## DETAIL RE007-EROSION CONTROL-WATTLE-2

### GENERAL NOTES:

At cut or fill slope installations, wattles shall be installed along the contour and perpendicular to the water flow.

At ditch installations, point A must be higher than point B to ensure that water flows over the wattle and not around the ends.

The Contractor shall dig a 3" to 5" trench, install the wattle tightly in the trench so that daylight can not be seen under the wattle, and then compact the soil excavated from the trench against the wattle on the uphill side. See Detail B.

The stakes shall be 1"x2" or 2"x2" wood stakes, however, other types of stakes such as rebar may be used only if approved by the Engineer. The stakes shall be placed 6" from the ends of the wattles and the spacing of the stakes along the wattles shall be 3' to 4'.

When installing running lengths of wattles, the Contractor shall butt the second wattle tightly against the first and shall not overlap the ends. See Detail C.

The Contractor and Engineer shall inspect the erosion control wattles once every week and within 24 hours after every rainfall event greater than 1/2". The Contractor shall remove, dispose, or reshape the accumulated sediment when necessary as determined by the Engineer.

Sediment removal, disposal, or necessary shaping shall be as directed by the Engineer. All costs for removing accumulated sediment, disposal of sediment, and necessary shaping shall be incidental to the contract unit price per cubic yard for "Remove Sediment".

All costs for furnishing and installing the erosion control wattles including labor, equipment, and materials shall be incidental to the contract unit price per foot for the corresponding erosion control wattle bid item.

All costs for removing the erosion control wattle from the project including labor, equipment, and materials shall be incidental to the contract unit price per foot for "Remove Erosion Control Wattle".

### **EROSION CONTROL-WATTLE**

**NOT TO SCALE**

**CITY OF BOX ELDER**

**STANDARD DETAIL**

**EROSION CONTROL-WATTLE-2**



DETAIL #RE007

REVISED 01/2020

**DETAIL RE008-EROSION CONTROL-INLETS-1**

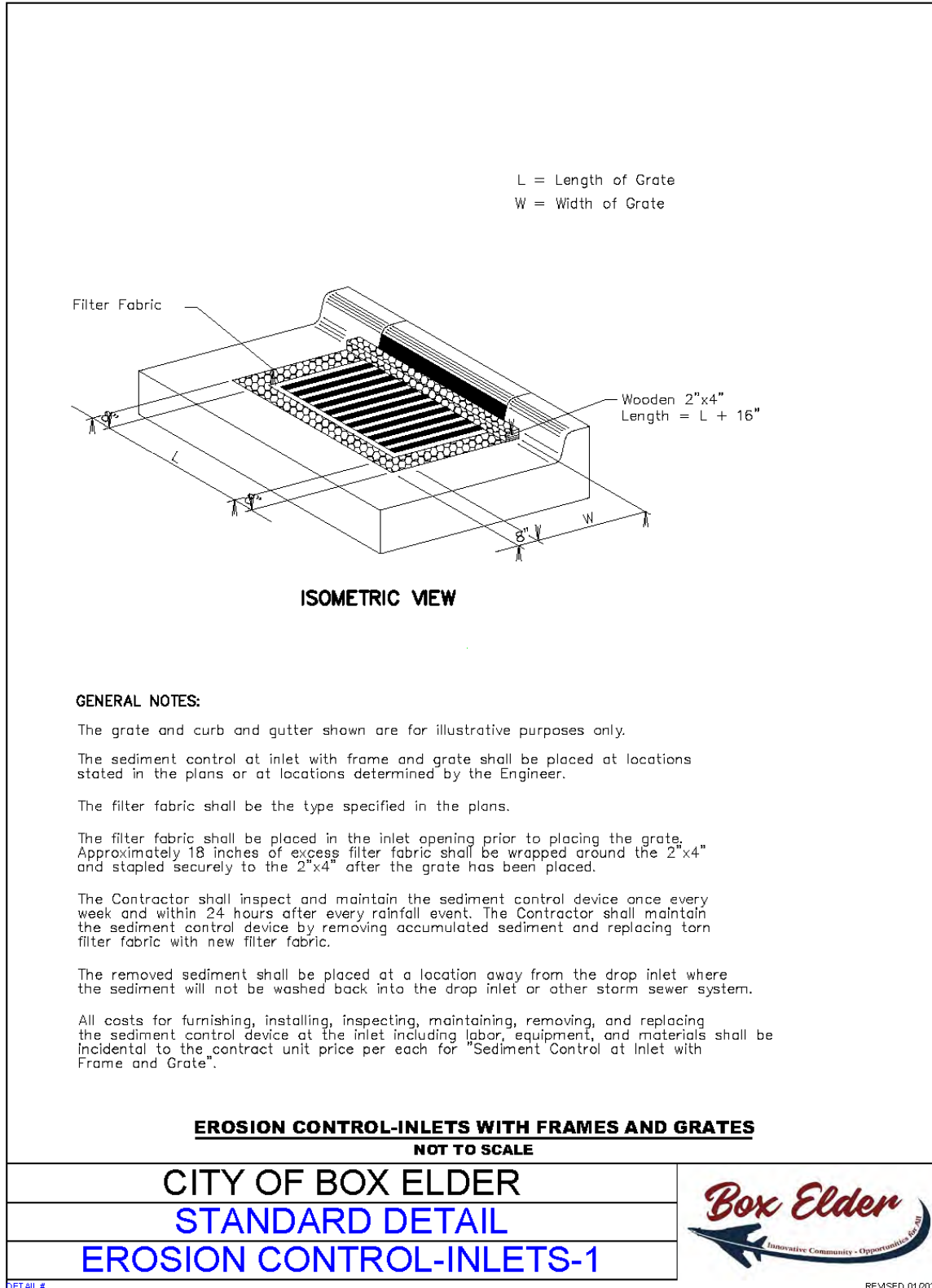

**DETAIL RE009-EROSION CONTROL-INLETS-2**

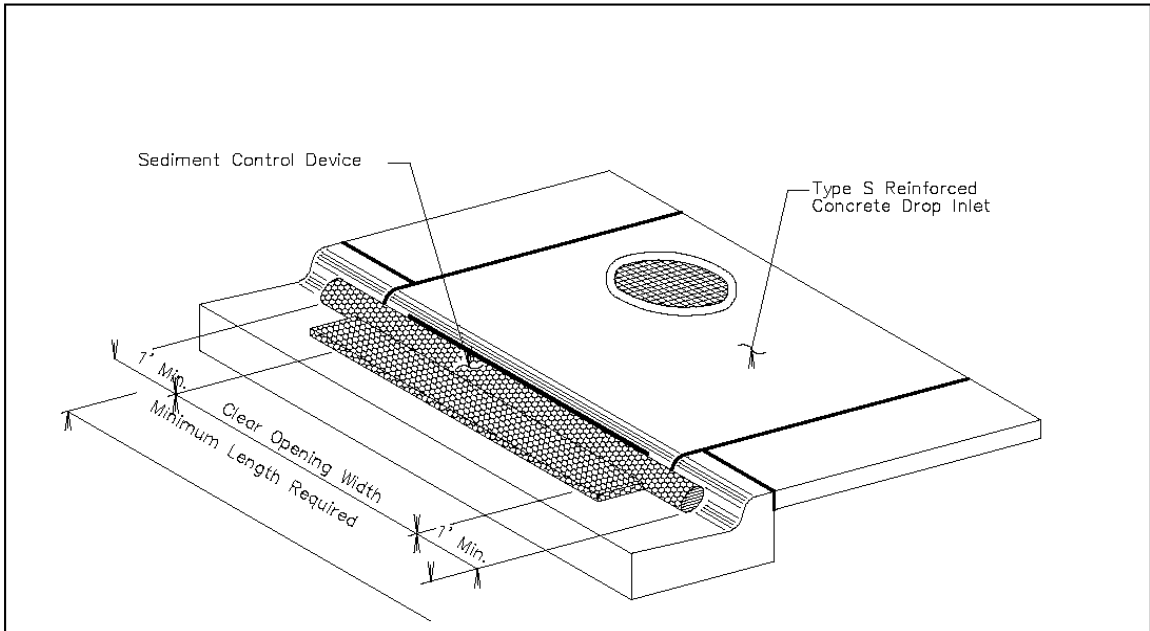

**ISOMETRIC VIEW**

**GENERAL NOTES:**

The type of sediment control device shown is for illustrative purposes only.

The type of sediment control device used shall be one of the types as specified in the plans.

The sediment control device shall be placed at the drop inlets according to the manufacturers' installation instructions.

The sediment control at inlet for type S reinforced concrete drop inlet shall be placed at locations stated in the plans or at locations determined by the Engineer.

The Contractor shall inspect and maintain the sediment control device once every week and within 24 hours after every rainfall event. The Contractor shall maintain the sediment control device by removing the device, removing accumulated sediment, and resetting the device.

The removed sediment shall be placed at a location away from the drop inlet where the sediment will not be washed back into the drop inlet or other storm sewer system.

Payment for the "Sediment Control at Type S Drop Inlet" shall be based on the minimum length required at the drop inlets. Some of the sediment control devices specified in the plans will have to be longer due to available length.

All costs for furnishing, installing, inspecting, maintaining, removing, and resetting the sediment control device at the drop inlet including labor, equipment, and materials shall be incidental to the contract unit price per foot for "Sediment Control at Type S Reinforced Concrete Drop Inlet".

**EROSION CONTROL-INLETS FOR TYPE S DROP INLETS**

**NOT TO SCALE**

**CITY OF BOX ELDER**  
**STANDARD DETAIL**  
**EROSION CONTROL-INLETS-2**



DETAIL #RE009

REVISED 01/2020

## DETAIL RE020-EROSION CONTROL-GABION-1

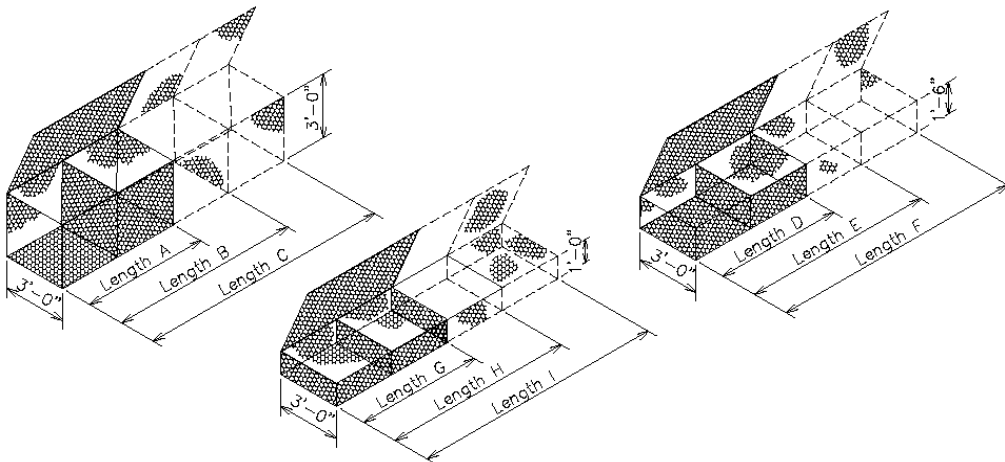

**GABION DETAILS  
STANDARD SIZES**

SIZE	LENGTH	WIDTH	HEIGHT	NUMBER OF CELLS	CAPACITY, Cu. Yd.
A	6'-0"	3'-0"	3'-0"	2	2.0
B	9'-0"	3'-0"	3'-0"	3	3.0
C	12'-0"	3'-0"	3'-0"	4	4.0
D	6'-0"	3'-0"	1'-6"	2	1.0
E	9'-0"	3'-0"	1'-6"	3	1.5
F	12'-0"	3'-0"	1'-6"	4	2.0
G	6'-0"	3'-0"	1'-0"	2	0.7
H	9'-0"	3'-0"	1'-0"	3	1.0
I	12'-0"	3'-0"	1'-0"	4	1.3

Above Dimensions subject to mill tolerances.

**GENERAL NOTES:**

Lacing and internal connecting wire shall be 0.0866 inch diameter steel wire ASTM A641 Class 3 soft temper measured after galvanizing and for PVC coated gabions shall be 0.0866 inch diameter steel wire measured after galvanizing but before PVC coating.

The lacing procedure is as follows:

1. Cut a length of lacing wire approximately 1 times the distance to be laced but not exceeding 5 feet.
2. Secure the wire terminal at the corner by looping and twisting.
3. Proceed lacing with alternating single and double loops at a spacing not to exceed 6 inches.
4. Securely fasten the other lacing wire terminal.

Wire lacing or interlocking type fasteners shall be used for gabion assembly and final construction of gabion structures. Interlocking fasteners for galvanized gabions shall be high tensile 0.120 inch diameter galvanized steel wire measured after galvanizing. The galvanizing shall conform to ASTM A641-92 Class 3 coating. Fasteners shall also be in accordance with ASTM A764, Class II, Type III.

Interlocking fasteners for PVC coated gabions shall be high tensile 0.120 inch diameter stainless steel wire conforming to ASTM A313, Type 302, Class 1. The spacing of the interlocking fasteners during all phases of assembly and construction shall not exceed 6 inches.

All fasteners shall be placed where the mesh weaves around the selvaige wire at the vertical and horizontal joints.

**EROSION CONTROL-GABION-BANK AND CHANNEL**

**NOT TO SCALE**

**CITY OF BOX ELDER  
STANDARD DETAIL  
EROSION CONTROL-GABION-1**



DETAIL #RE020

REVISED 01/2020

**DETAIL RE021-EROSION CONTROL-GABION-2**

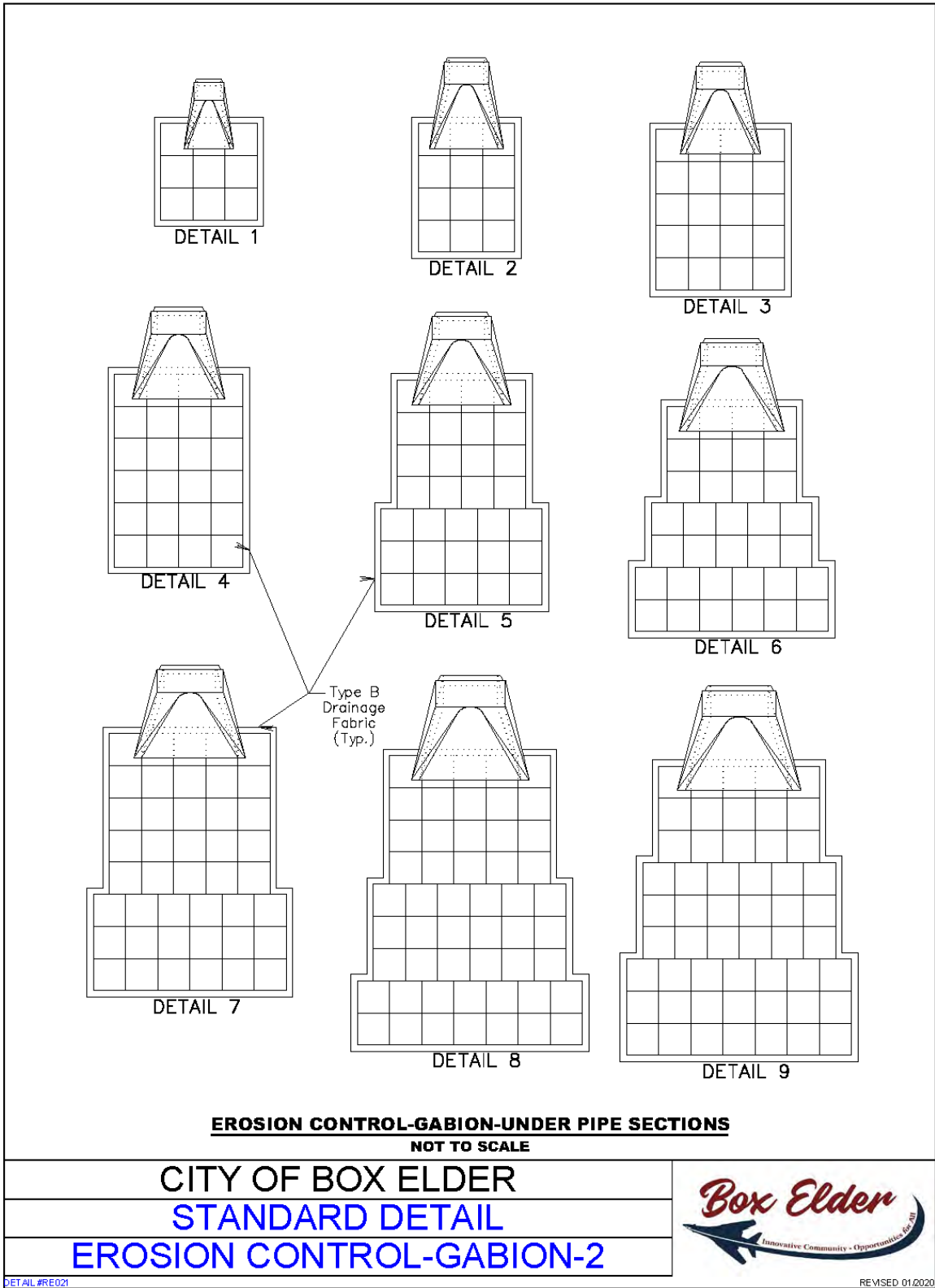



**DETAIL RE022-EROSION CONTROL-GABION-3**

ESTIMATED QUANTITIES *				
Detail	Pipe Diameter (Inches)	Gabion (Cu. Yd.)	Type B Drainage Fabric (Sq. Yd.)	
<b>RCP, RCP Arch, CMP, and CMP Arch</b>	1	12, 18, and 24	4.5	15
	2	30 and 36	6.0	19
	3	42	10.0	29
	4	48 and 54	12.0	34
	5	60	15.5	43
	6	66	17.0	47
	7	72	21.5	57
	8	78	26.0	68
	9	84	27.0	70

**GENERAL NOTES:**

Gabions at outlets of CMP and RCP shall be placed under the end section a distance of 2' from the outlet end. For CMP end section installations, the upper fabric of the gabions shall be modified to accommodate the metal end section as approved by the Engineer.

\*

Gabion and type B drainage fabric quantities on this standard plate are based on standard gabion sizes D, E, and F as depicted on Standard Plate 720.01.

Type B drainage fabric shall be placed under the gabions and around the exterior sides (perimeter) of the gabions as approved by the Engineer. The type B drainage fabric shall be in conformance with Section 831 of the Specifications. Measurement and payment of the type B drainage fabric shall be in conformance with Section 720 of the Specifications.

**EROSION CONTROL-GABION-UNDER PIPE END SECTIONS**

**NOT TO SCALE**

**CITY OF BOX ELDER**  
**STANDARD DETAIL**  
**EROSION CONTROL-GABION-3**



DETAIL #RE022

REVISED 01/2020

**DETAIL RE030-EROSION CONTROL-DITCH**

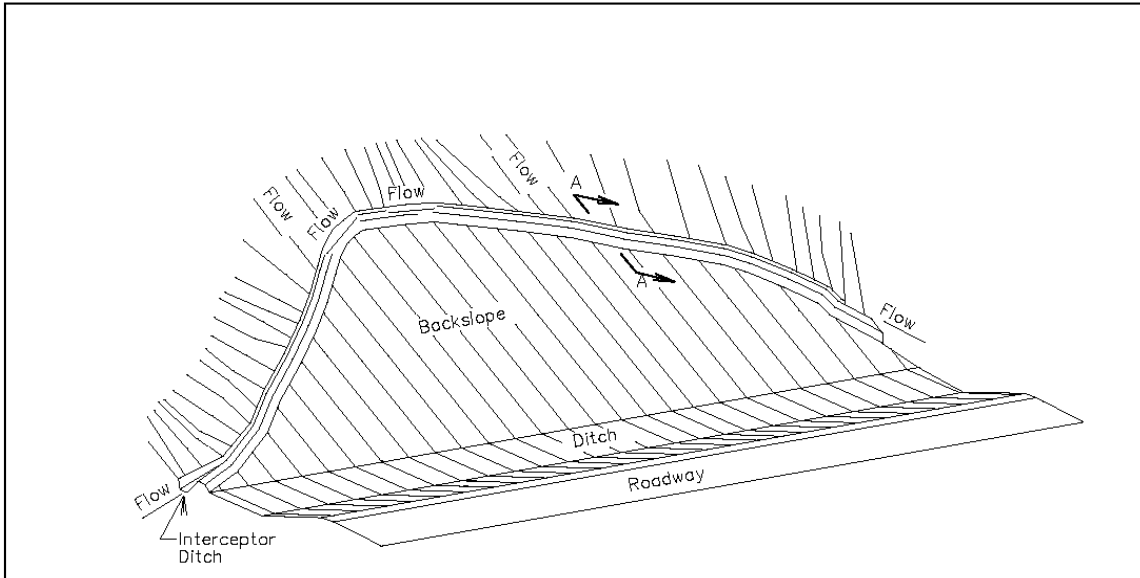

**ISOMETRIC VIEW**

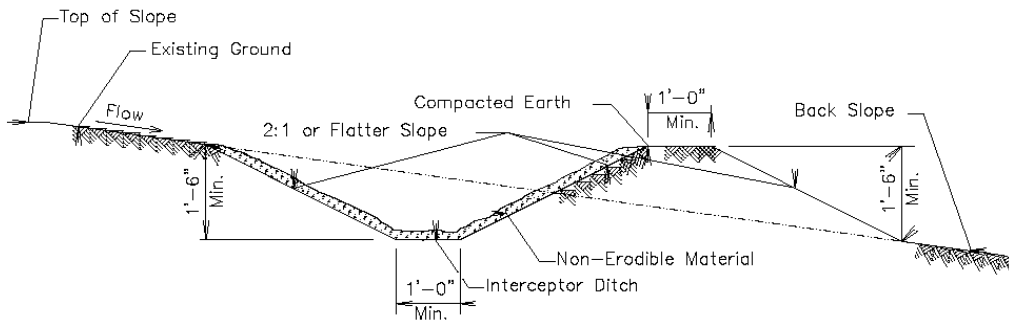

**SECTION A-A**

**GENERAL NOTES:**

The Contractor shall inspect the interceptor ditch once every week and within 24 hours after every rainfall event. The Contractor shall maintain the interceptor ditch by removing accumulated sediment once it has reached a depth of 1'.

The non-erodible material used shall be an erosion control blanket or a 2" thickness of shotrock, base course, or gravel cushion material.

The Engineer shall determine when or if the interceptor ditch shall be removed.

All costs for constructing, inspecting, and maintaining the interceptor ditch including labor, equipment, and materials shall be incidental to the contract unit price per foot for "Cut Interceptor Ditch".

**EROSION CONTROL-CUT INTERCEPTOR DITCH**

**NOT TO SCALE**

<p><b>CITY OF BOX ELDER</b></p> <p><b>STANDARD DETAIL</b></p> <p><b>EROSION CONTROL-DITCH</b></p>
---



DETAIL #RE030

REVISED 01/2020

## DETAIL RE031-EROSION CONTROL-SLOPE DRAIN

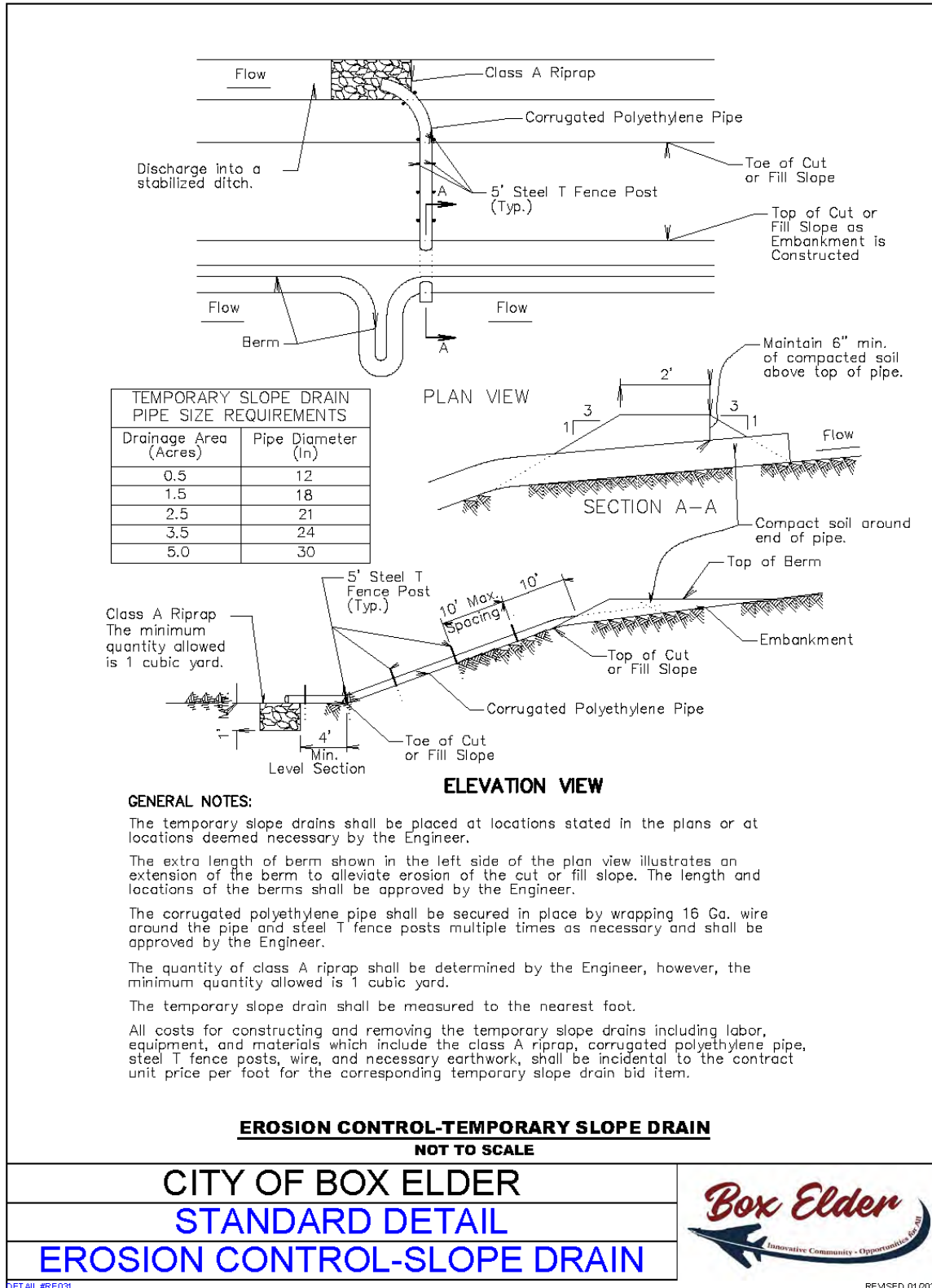

# DETAIL RE032-EROSION CONTROL-SURFACE ROUGHENING

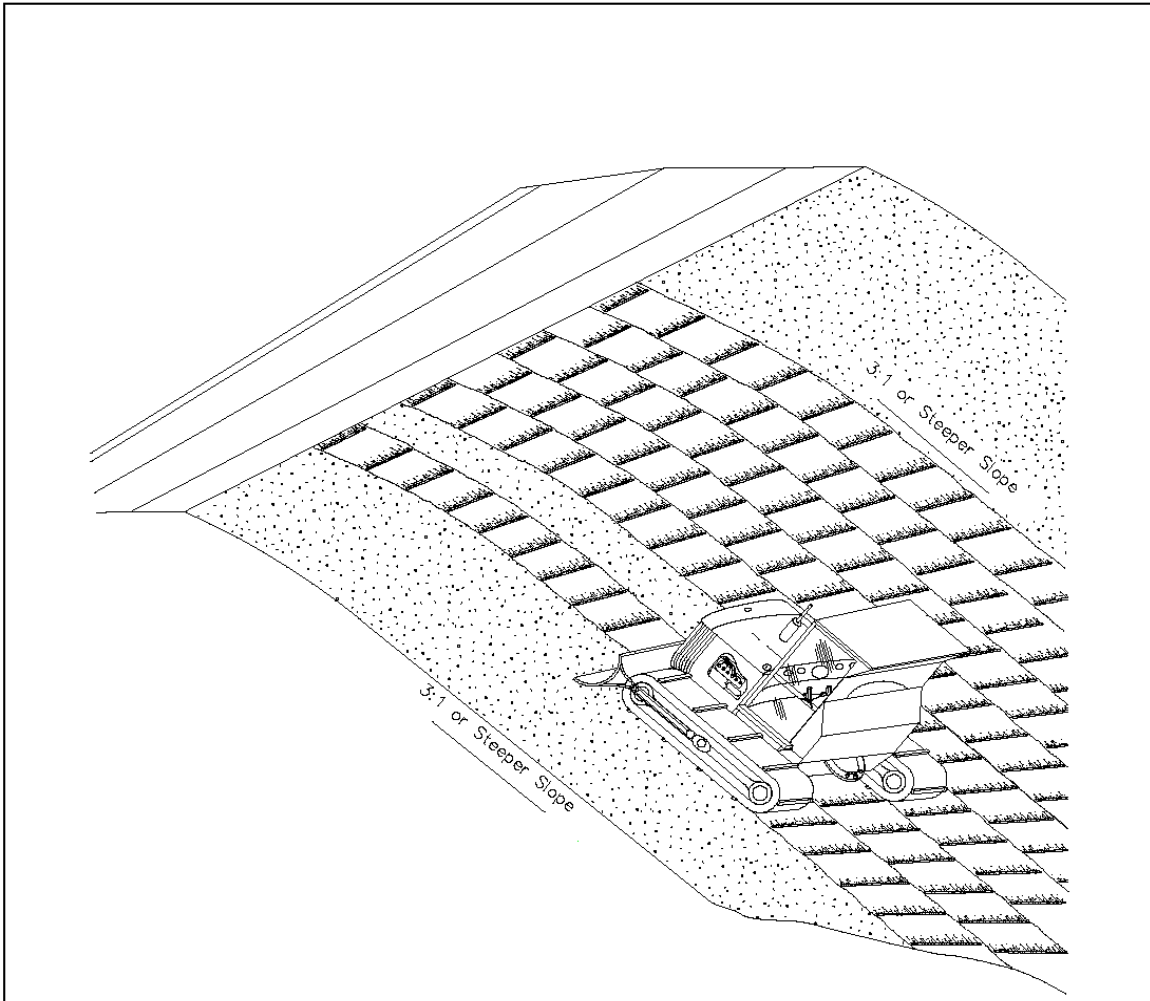

**GENERAL NOTES:**

Where practical, surface roughening shall be done on slopes 3:1 and steeper and on slopes deemed necessary by the Engineer.

The equipment used for surface roughening shall be equipped with tracks that are capable of creating ridges in the soil that are perpendicular to the slope. The final condition of the surface roughening shall be approved by the Engineer.

Measurement for surface roughening shall be to the nearest tenth of an acre.

All costs associated with surface roughening including labor, equipment, and materials shall be incidental to the contract unit price per acre for "Surface Roughening".

**EROSION CONTROL-SURFACE ROUGHENING**

**NOT TO SCALE**

**CITY OF BOX ELDER**

**STANDARD DETAIL**

**EROSION CONTROL-SURFACE ROUGH**



DETAIL #RE032

REVISED 01/2020

## DETAIL RF001-FENCING-RIGHT-OF-WAY

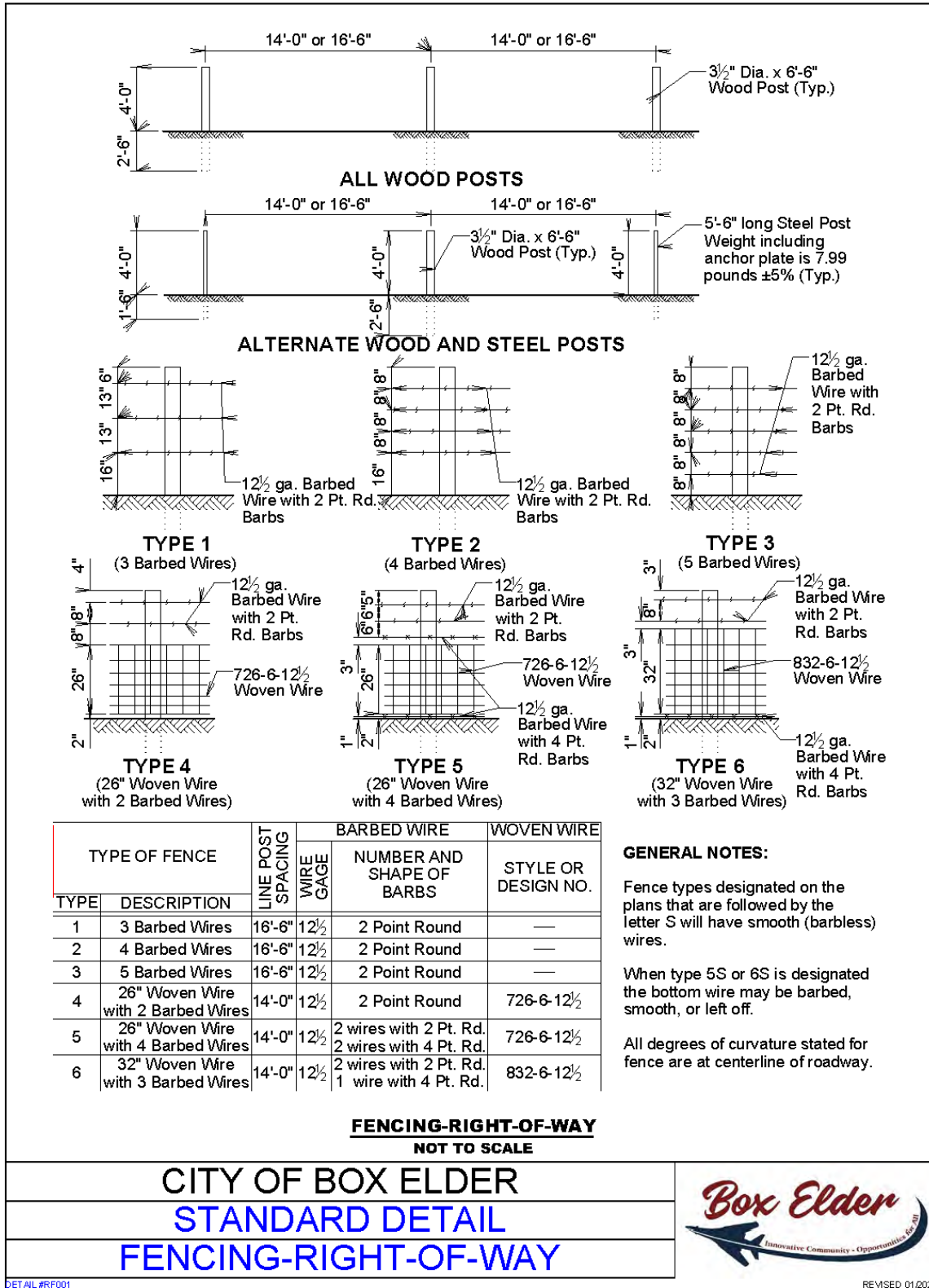

## DETAIL RF002-FENCING INSTALLATION

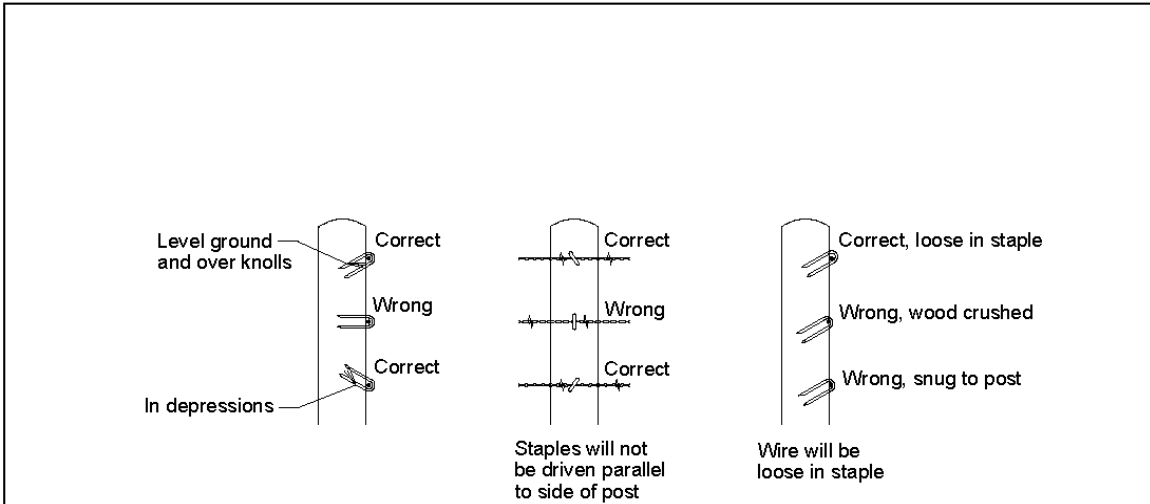

### STAPLE INSTALLATION

**GENERAL NOTES:**

The Right-of-Way fence will consist of barbed wire or a combination of woven wire and barbed wire. The barbed wire and/or woven wire will be fastened to all wood posts or fastened to alternating wood and steel posts. Only wood posts will be used for brace panels. Gates will be of the type designated in the plans or as otherwise directed by the Engineer. Fence will be constructed conforming to the details on the standard plates and in the plans unless otherwise directed by the Engineer.

Right-of-Way fence on Interstate Projects will be constructed one foot within the Interstate Right-of-Way lines except at bridge openings, cattle passes, and as otherwise directed by the Engineer.

Right-of-Way fence other than on Interstate Projects will be constructed within one foot of the Right-of-Way on the Landowner's side except at bridge openings, cattle passes, and as otherwise directed by the Engineer.

Barbs will be fabricated from zinc coated 14 ga. wire. Two point barbs will be wrapped twice around one main strand at four-inch spacings and the four point barbs will be interlocked and wrapped around both main strands at five-inch spacings.

The gages of wire and wood post lengths and sizes are the minimum acceptable unless otherwise specified in the plans. The tolerances for steel posts will be as stated in AASHTO M281. Woven wire will conform to design and specifications of ASTM A116 and barbed wire will conform to ASTM A121.

**FENCING-RIGHT-OF-WAY INSTALLATION**

NOT TO SCALE

CITY OF BOX ELDER	
STANDARD DETAIL	
FENCING-RIGHT-OF-WAY INSTALL	

DETAIL #RF002

REVISED: 01/2020

**DETAIL RF003-FENCING-BRACE PANEL AND APPLICATIONS**

**ENTRANCE**  
(Not on corner)

Fence type will be same as adjacent fence type or as directed by the Engineer.

Fence type will be same as adjacent fence type or as directed by the Engineer.

**DOUBLE ENTRANCES**      **ENTRANCES AT CORNERS**

**GATES**

\* If fence length is less than 600' to next corner use a 2 post panel.  
\* If fence length is greater than 600' to next corner use a 3 post panel.  
Ⓛ See Detail B on Sheet 1 of 3.

**FENCING-BRACE PANELS AND APPLICATIONS**  
**NOT TO SCALE**

<b>CITY OF BOX ELDER</b>	
<b>STANDARD DETAIL</b>	
<b>FENCING-BRACE PANEL APP.-1</b>	

DETAIL #RF003

REVISED 01.2020

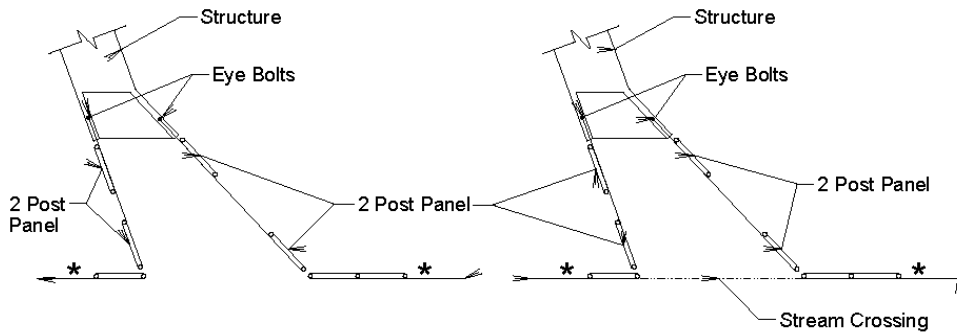
**DETAIL RF004-FENCING-BRACE PANEL APPLICATIONS AT STRUCTURES**

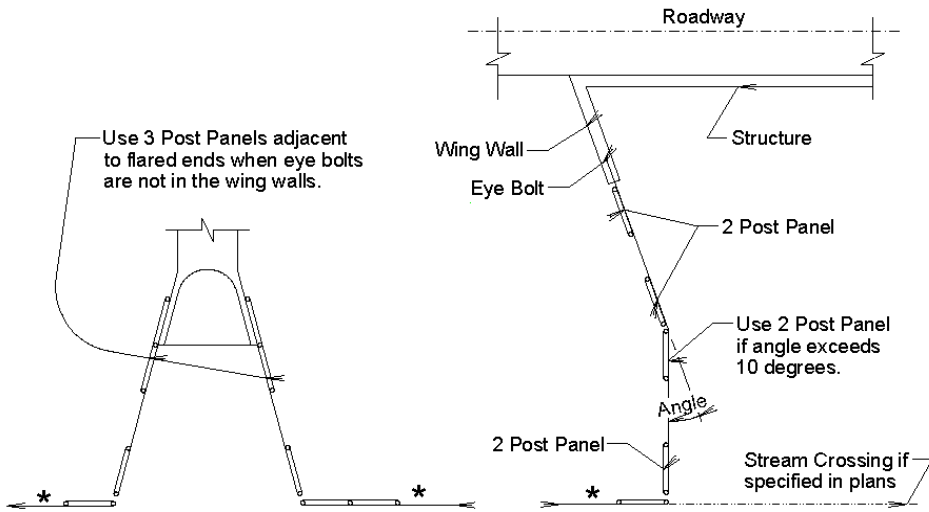

**R.C. BOX CULVERT  
OR CATTLE PASS**

**STRUCTURE WITH STREAM  
CROSSING FENCE**



**R.C. BOX CULVERT  
OR CATTLE PASS**

**BRIDGE**

\* If fence length is less than 600' to next corner use a 2 post panel.  
\* If fence length is greater than 600' use a 3 post panel.

**FENCING-BRACE PANEL APPLICATIONS AT STRUCTURES**

NOT TO SCALE

**CITY OF BOX ELDER**  
**STANDARD DETAIL**  
**FENCING-BRACE PANEL APP.-2**



DETAIL #RF004

REVISED 01/2020



# DETAIL RF005-FENCING-WIDE DEPRESSIONS AND STREAM CROSSINGS

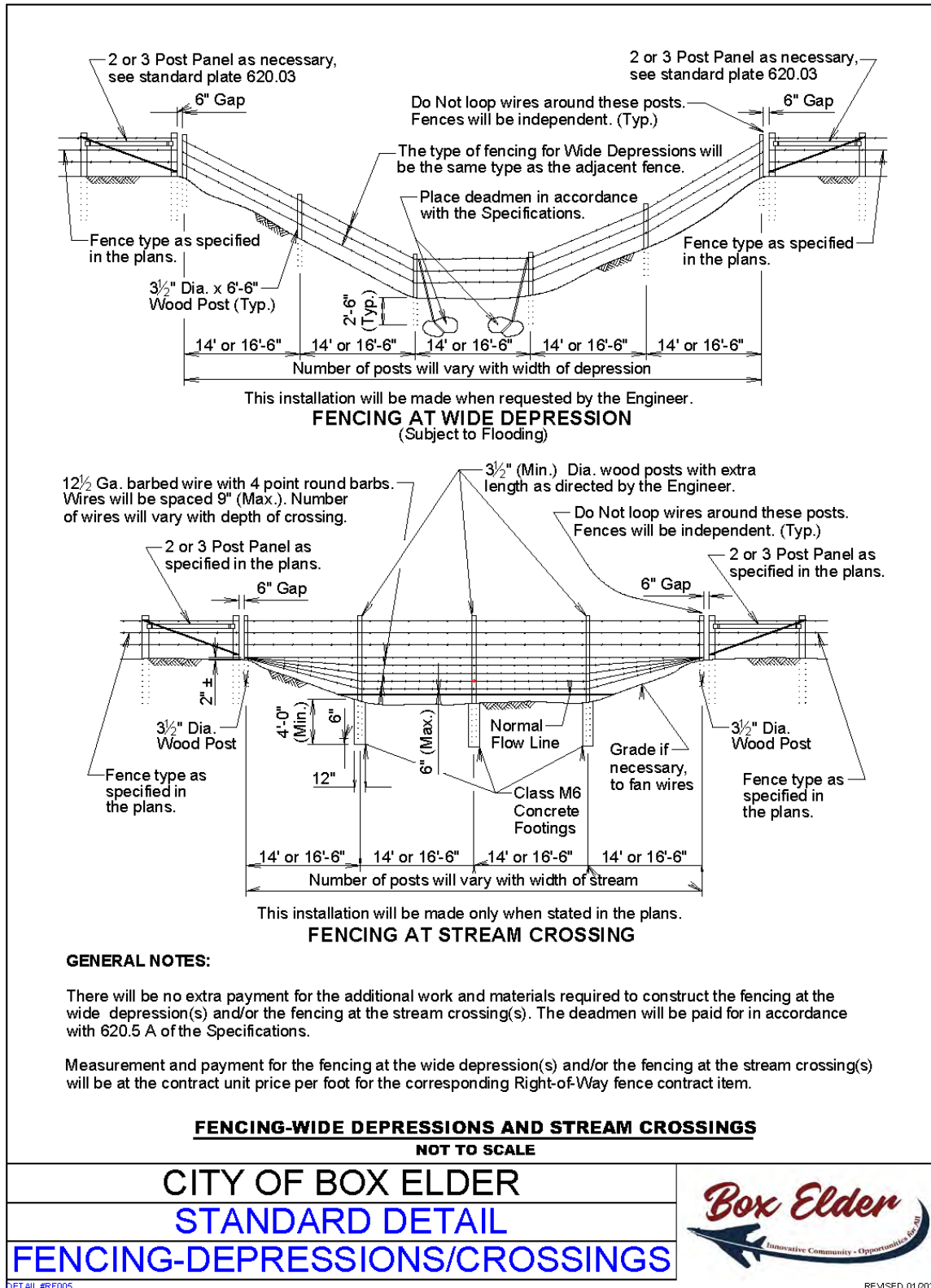

## DETAIL RF006-FENCING-GROUNDING

**BARBED WIRE FENCE**

**WOVEN WIRE FENCE**

**CHAIN LINK FENCE**

**GROUND ROD DETAIL**

**GENERAL NOTES:**

Details shown on this standard plate will apply to all types of Right-of-Way fence constructed with all wood posts or chain link fence.

Continuous fence in urban areas will be grounded at maximum intervals of 500 feet. Continuous fence in rural areas will be grounded at maximum intervals of 1000 feet. There will be a ground at a maximum of 100 feet from a gate in each adjacent section of fence.

Fence placed under a power line will be grounded with three grounds. One ground will be placed directly below the crossing and the other two will be placed 25 feet to 50 feet away, one on each side.

One ground will be placed directly below each telephone or cable crossing.

Ground rods will be located on the post side of the fence and will be as close as possible to the post and fence.

The cost of furnishing and placing all materials for grounding will be incidental to the contract unit price per foot for the respective Right-of-Way fence or chain link fence contract item.

The approximate quantities of materials per each installation of a ground are:

- 1 ground rod clamp.
- 1  $\frac{5}{8}$ " diameter x 8' long copper clad ground rod
- 1 #6 AWG bare copper wire; 7' long for Right-of-Way fence or 10' long for chain link fence.

Compression type or other type of connectors:  
 26" woven wire will have a total of two connectors, one secured to the top and one secured to the bottom.  
 32" woven wire will have a total of three connectors, one secured to the top, one secured to the middle, and one secured to the bottom.  
 One connector will be used for each strand of barbed wire.  
 A minimum of 3 connectors will be installed on chain link fence, the connectors will be placed vertically at every 2-foot increment and connectors will be placed on the top and bottom tension wires or top rail.

**FENCING-GROUNDING**  
NOT TO SCALE

**CITY OF BOX ELDER**

**STANDARD DETAIL**

**FENCING-GROUNDING**

DETAIL #RF006
REVISED 01/2020

**DETAIL RF010-FENCING-WIRE GATES**

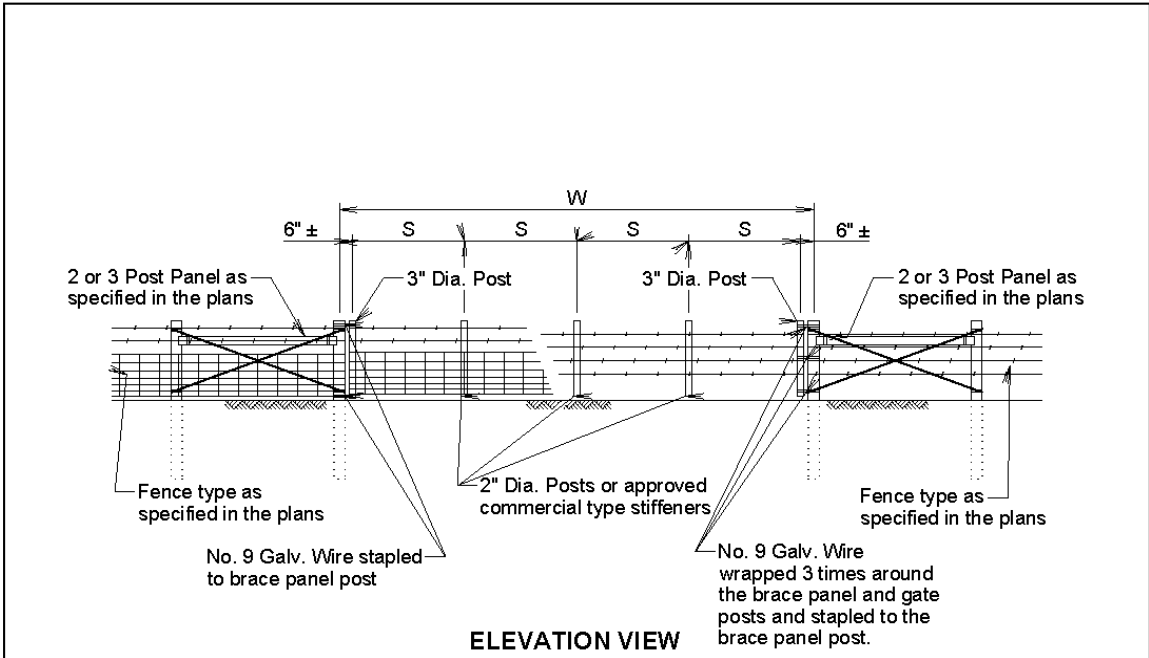

**ELEVATION VIEW**

W Gate Width (Ft.)	S Post Spacing
16	3 @ 5'-0" ±
20	4 @ 4'-9" ±
24	4 @ 5'-9" ±
30	5 @ 5'-10" ±
40	6 @ 6'-6" ±

**GENERAL NOTES:**

Creosote treatment of the gate posts will not be accepted.

The type of fencing in the gate will be of the same type as specified for the adjacent Right-of-Way fence.

All costs for furnishing and constructing the wire gate(s) will be incidental to the contract unit price per foot for the respective Right-of-Way fence contract item.

**FENCING-WIRE GATES  
NOT TO SCALE**

<p><b>CITY OF BOX ELDER</b> <b>STANDARD DETAIL</b> <b>FENCING-WIRE GATES</b></p>
--



DETAIL #RF010

REVISED 01/2020

## DETAIL RF011-FENCING-TUBULAR FRAME GATES

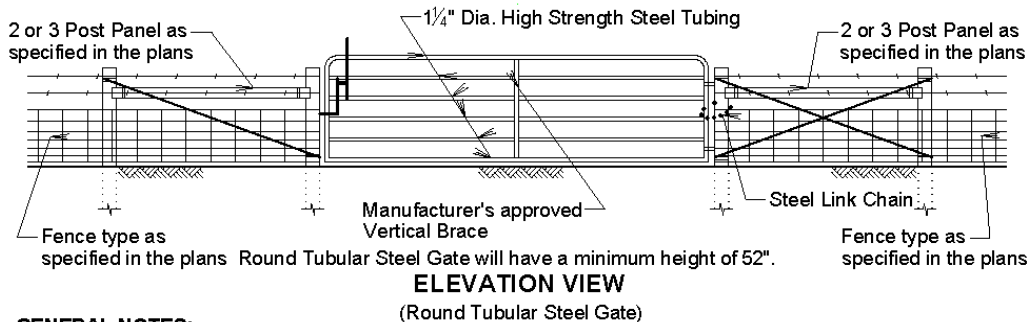
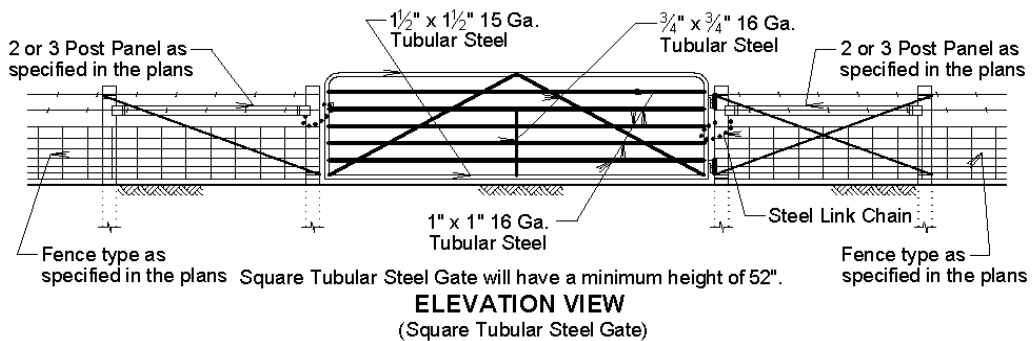
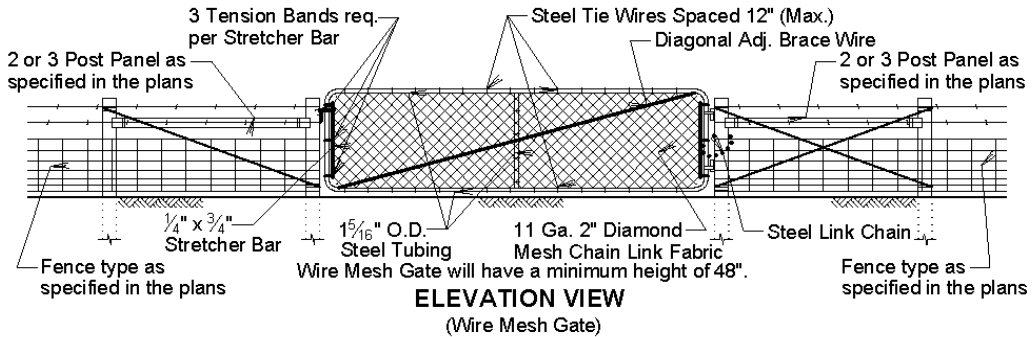

**GENERAL NOTES:**

Only single tubular frame gates are shown on this standard plate. If double tubular frame gates are specified, the gates will be of the same type and materials as shown above. Double tubular gates will swing toward the middle of the opening and will be secured by a chain, latch, or other suitable hardware.

Gate hardware will conform to the specific type of gate installed. The gate and gate hardware will either be painted or galvanized. The paint on the gates and hardware will be subject to approval by the Engineer.

The Steel Link Chain will be a minimum of 1/4", 4' long, rust resistant, and have electrically welded links. The chain will be wrapped around the gate hinge post and gate frame and the ends of the chain will be welded together with enough slack in the chain to provide free operation of the gate.

**FENCING-TUBULAR FRAME GATES**  
**NOT TO SCALE**

<b>CITY OF BOX ELDER</b>
<b>STANDARD DETAIL</b>
<b>FENCING-TUBULAR FRAME GATES</b>



DETAIL #RF011

REVISED 01/2020

**DETAIL RF020-FENCING-ANCHORS FOR BOX CULVERT WING WALLS**

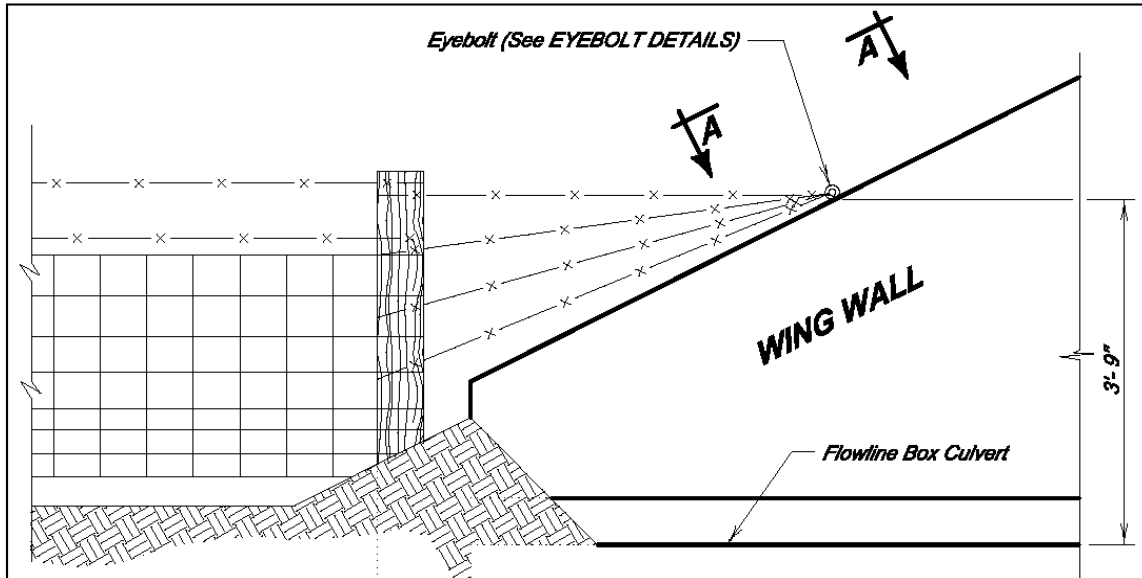

**DETAIL FOR FENCE ANCHORS**

**GENERAL NOTES:**

1. The fence and post details shown are for illustrative purpose only. The fence shall be as specified elsewhere in the plans.
2. Eyebolts shall be placed on all of the box culvert wing walls.
3. Eyebolts shall be 5/8 inch diameter and shall conform to ASTM A307.
4. Eyebolts, nuts, and concrete inserts shall be galvanized in accordance with AASHTO M232 (ASTM A153). Concrete inserts of corrosion resistant material need not be galvanized.
5. Cast-in-place eyebolts shall have a nut attached, be 4 1/2 inches (Min.) in length and shall be embedded such that the eye of the bolt is flush with the concrete surface. (See Eyebolt Details) As an alternate, cast-in-place concrete inserts, capable of developing the full strength of the 5/8 inch diameter threaded eyebolt, may be used and shall be set in the concrete in accordance with the manufacturer's recommendations. The eyebolt shall be of sufficient length to develop its full strength. The eye of the eyebolt shall be flush with the concrete surface.
6. The cost for furnishing and installing eyebolts and/or concrete inserts shall be incidental to various contract items.

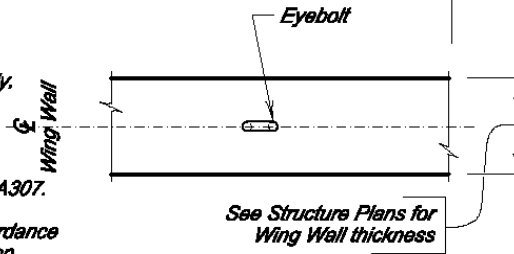

**VIEW A - A**

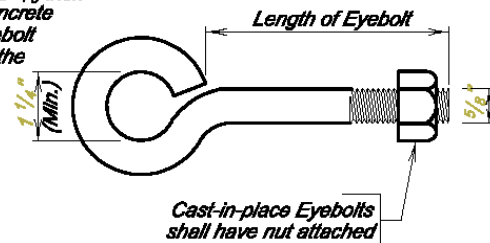

**EYEBOLT DETAILS**

**FENCING-ANCHORS FOR BOX CULVERT WING WALLS**

NOT TO SCALE

CITY OF BOX ELDER  
**STANDARD DETAIL**  
**FENCING-ANCHORS-1**



DETAIL #RF020

REVISED 01/2020

**DETAIL RF021-FENCING-ANCHORS FOR BRIDGE ABUTMENT WING WALLS (>6')**

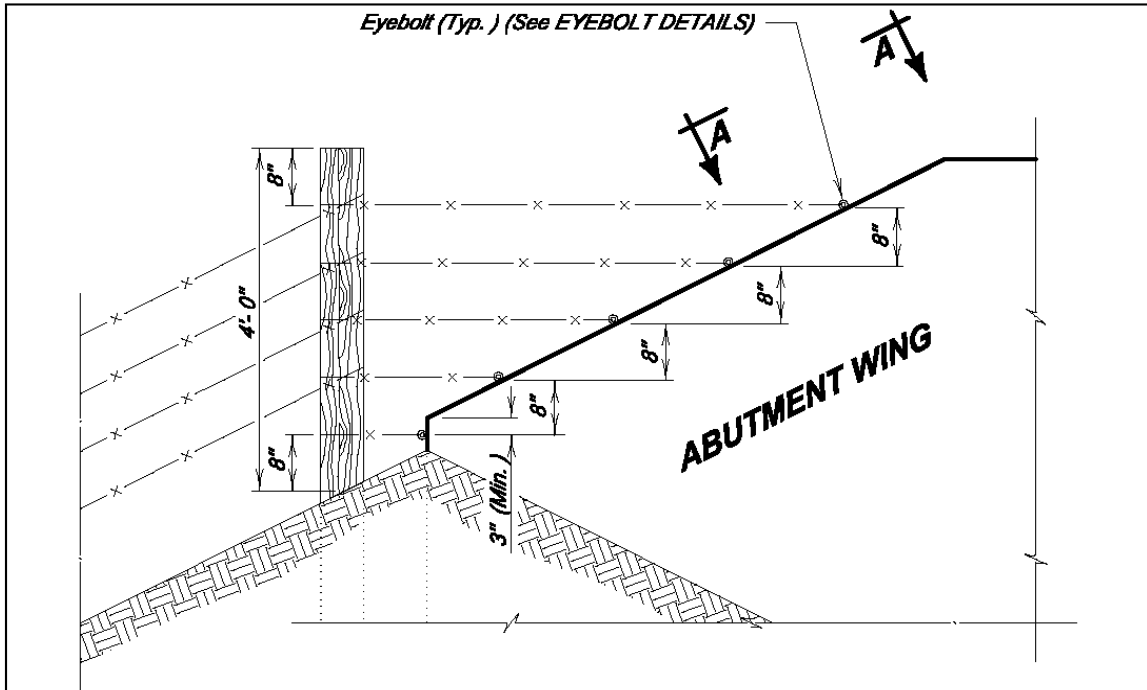

**GENERAL NOTES:      DETAIL FOR FENCE ANCHORS**

1. The fence and post details shown are for illustrative purpose only. The fence shall be as specified elsewhere in the plans.
2. Eyebolts shall be placed on all of the bridge abutment wings.
3. Eyebolts shall be  $\frac{5}{8}$  inch diameter and shall conform to ASTM A307.
4. Eyebolts, nuts, and concrete inserts shall be galvanized in accordance with AASHTO M232 (ASTM A153). Concrete inserts of corrosion resistant material need not be galvanized.
5. Cast-in-place eyebolts shall have a nut attached, be  $4\frac{1}{2}$  inches (Min.) in length and shall be embedded such that the eye of the bolt is flush with the concrete surface. (See Eyebolt Details) As an alternate, cast-in-place concrete inserts, capable of developing the full strength of the  $\frac{5}{8}$  inch diameter threaded eyebolt, may be used and shall be set in the concrete in accordance with the manufacturer's recommendations. The eyebolt shall be of sufficient length to develop its full strength. The eye of the eyebolt shall be flush with the concrete surface.
6. The cost for furnishing and installing eyebolts and/or concrete inserts shall be incidental to various contract items.

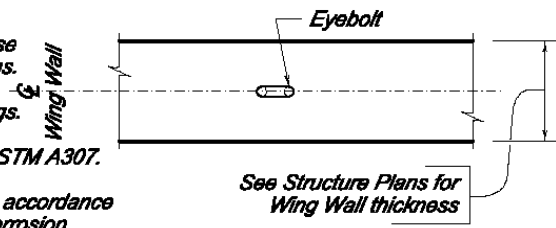

**VIEW A - A**

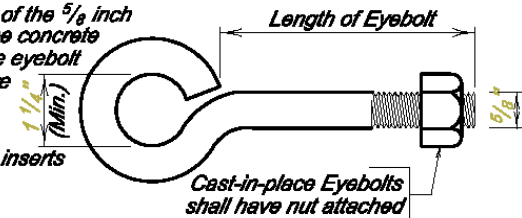

**EYEBOLT DETAILS**

**FENCING-ANCHORS FOR BRIDGE ABUTMENT WING WALLS (GREATER THAN 6')**

NOT TO SCALE

<p><b>CITY OF BOX ELDER</b></p> <p><b>STANDARD DETAIL</b></p> <p><b>FENCING-ANCHORS-2</b></p>
---



DETAIL #RF021

REVISED 01/2020

**DETAIL RF022-FENCING-ANCHORS FOR BRIDGE ABUTMENT WING WALLS (≤6')**

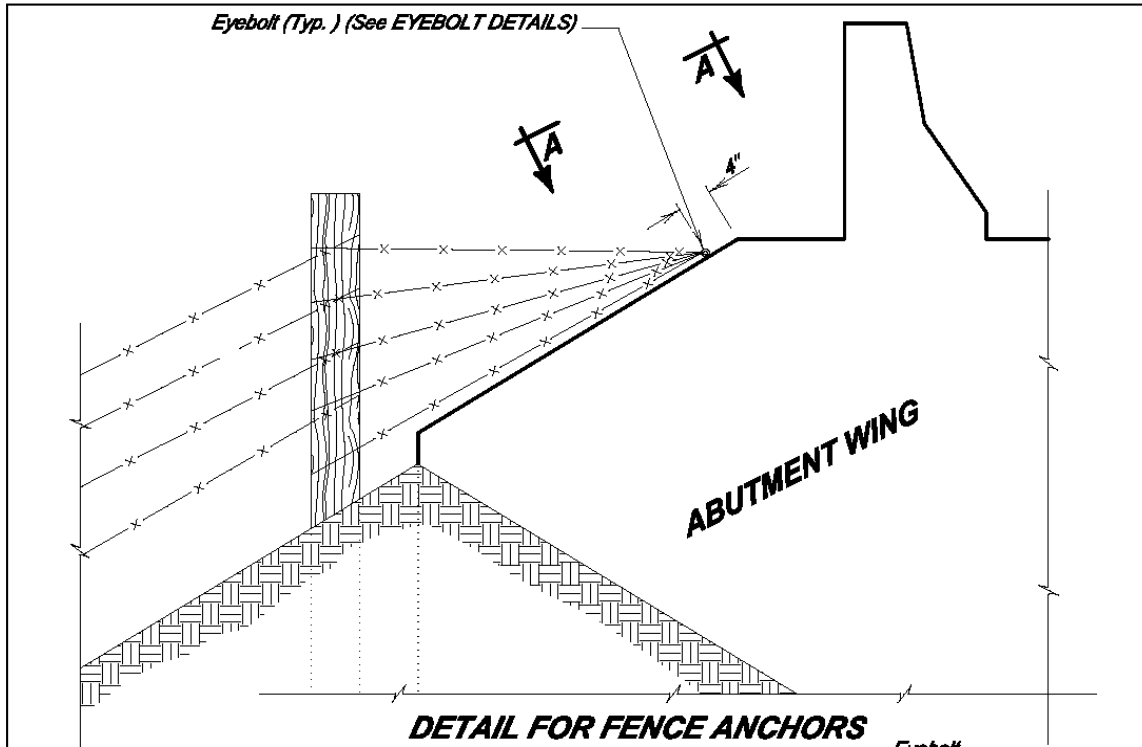

**DETAIL FOR FENCE ANCHORS**

**GENERAL NOTES:**

1. The fence and post details shown are for illustrative purpose only. The fence shall be as specified elsewhere in the plans.
2. Eyebolts shall be placed on all of the bridge abutment wings.
3. Eyebolts shall be 5/8 inch diameter and shall conform to ASTM A307.
4. Eyebolts, nuts, and concrete inserts shall be galvanized in accordance with AASHTO M232 (ASTM A153). Concrete inserts of corrosion resistant material need not be galvanized.
5. Cast-in-place eyebolts shall have a nut attached, be 4 1/2 inches (Min.) in length and shall be embedded such that the eye of the bolt is flush with the concrete surface. (See Eyebolt Details) As an alternate, cast-in-place concrete inserts, capable of developing the full strength of the 5/8 inch diameter threaded eyebolt, may be used and shall be set in the concrete in accordance with the manufacturer's recommendations. The eyebolt shall be of sufficient length to develop its full strength. The eye of the eyebolt shall be flush with the concrete surface.
6. The cost for furnishing and installing eyebolts and/or concrete inserts shall be incidental to various contract items.

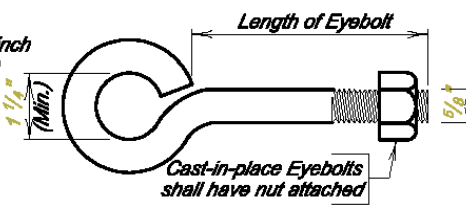
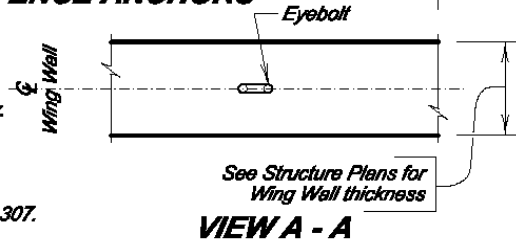

**FENCING-ANCHORS FOR BRIDGE ABUTMENT WING WALLS (6' AND LESS)**

NOT TO SCALE

CITY OF BOX ELDER  
**STANDARD DETAIL**  
**FENCING-ANCHORS-3**



DETAIL #RF022

REVISED 01/2020

# DETAIL RF023-FENCING-ANCHORS FOR BRIDGE ABUTMENT WITH SWEEP BACK WINGS

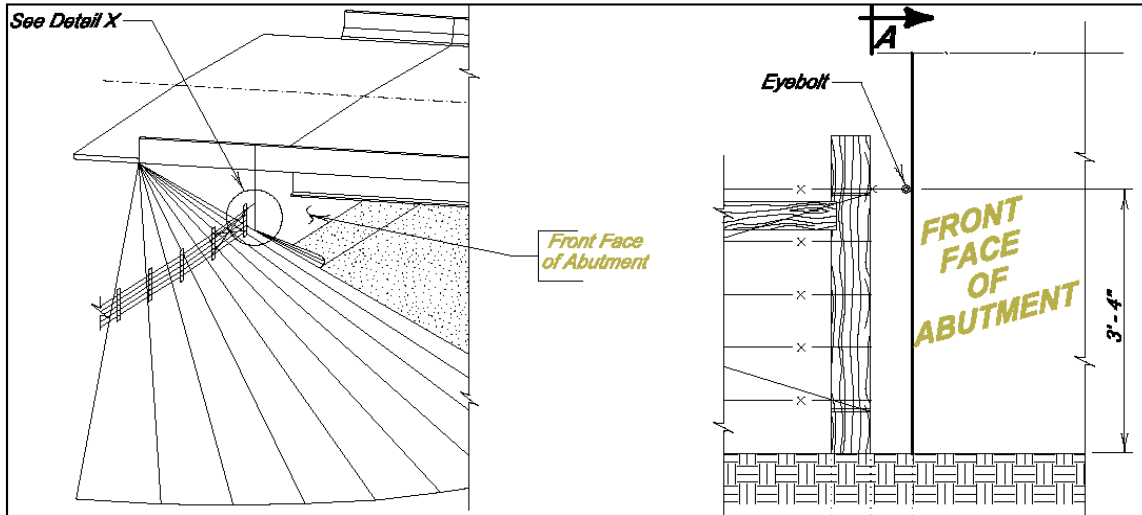

## DETAILS FOR FENCE ANCHORS

### GENERAL NOTES:

1. The fence and post details shown are for illustrative purpose only. The fence shall be as specified elsewhere in the plans.
2. Eyebolts shall be placed on all of the bridge abutment wings.
3. Eyebolts shall be  $\frac{5}{8}$  inch diameter and shall conform to ASTM A307.
4. Eyebolts shall be galvanized in accordance with AASHTO M232 (ASTM A153).
5. Eyebolts shall be installed after abutment wings are backfilled and berm construction is complete. Drill-in and epoxy eyebolts into abutment such that the eye of the bolt is flush with the concrete surface.
6. The epoxy resin mixture shall be of a type for bonding steel to hardened concrete and shall conform to AASHTO M235 Type IV, Grade 3 (Equivalent to ASTM C881, Type IV, Grade 3).
7. The diameter of the drilled holes shall not be less than  $\frac{1}{8}$  inch greater, nor more than  $\frac{3}{8}$  inch greater than the diameter of the eyebolts or per manufacturer's recommendations. The drilled holes shall be blown out with compressed air using a device that will reach the back of the hole to be sure that all debris or loose material has been removed prior to epoxy injection.
8. Mix epoxy resin as recommended by the Manufacturer and apply by an injection method as approved by the Engineer. Beginning at the back of the drilled holes, fill the holes  $\frac{1}{3}$  to  $\frac{1}{2}$  full of epoxy, or as recommended by the Manufacturer, prior to insertion of the eyebolts. Care shall be taken to prevent epoxy from flowing out of the horizontal holes prior to eyebolt insertion. Rotate the eyebolt during installation to eliminate voids and ensure complete bonding of the bolt. Insertion of the eyebolts by the dipping or painting method will not be allowed.
9. Loads shall not be applied to the epoxy grouted eyebolts until the epoxy resin has had sufficient time to cure as specified by the epoxy resin man.
10. The cost for furnishing and installing the eyebolts shall be incidental to various contract items.

**DETAIL "X"**

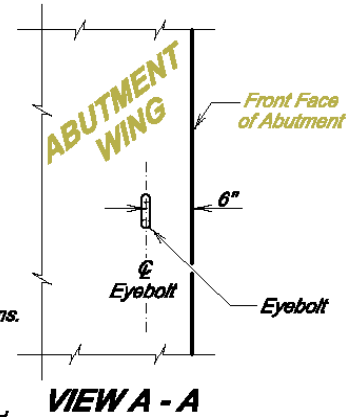

**VIEW A - A**

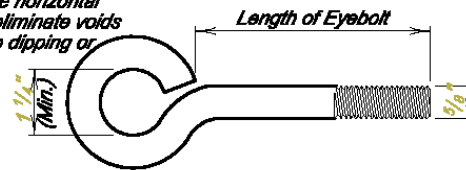

**EYEBOLT DETAILS**

## FENCING-ANCHORS FOR BRIDGE ABUTMENTS WITH SWEEP BACK WINGS

NOT TO SCALE

**CITY OF BOX ELDER**  
**STANDARD DETAIL**  
**FENCING-ANCHORS-4**



DET.AIL.#RF023

REVISED 01/2020



## DETAIL RG001-CURB & GUTTER-TYPE B

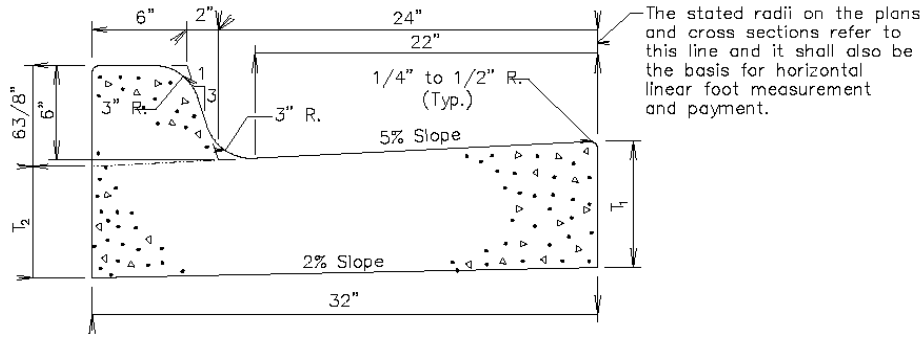

Type	T <sub>1</sub> (Inches)	T <sub>2</sub> (Inches)	Cu. Yd. Per Lin. Ft.	Lin. Ft. Per Cu. Yd.
B66	6	51/16	0.057	17.7
B67	7	61/16	0.065	15.4
B68	8	71/16	0.073	13.7
B68.5	8.5	79/16	0.077	13.0
B69	9	81/16	0.081	12.3
B69.5	9.5	89/16	0.085	11.7
B610	10	91/16	0.090	11.2
B610.5	10.5	99/16	0.094	10.7
B611	11	101/16	0.098	10.2
B611.5	11.5	109/16	0.102	9.8
B612	12	111/16	0.106	9.4

**GENERAL NOTES:**

When concrete curb and gutter longitudinally adjoins new concrete pavement, the method of attachment shall be by one of the methods shown on Standard Plate 380.11.

See Standard Plate 650.90 for expansion and contraction joints in the curb and gutter.

**CURB AND GUTTER-CONCRETE-TYPE B**

**NOT TO SCALE**

**CITY OF BOX ELDER**  
**STANDARD DETAIL**  
**CURB & GUTTER-TYPE B**



DETAIL #RG001

REVISED 01/2020

## DETAIL RG002-CURB & GUTTER-TYPE BL

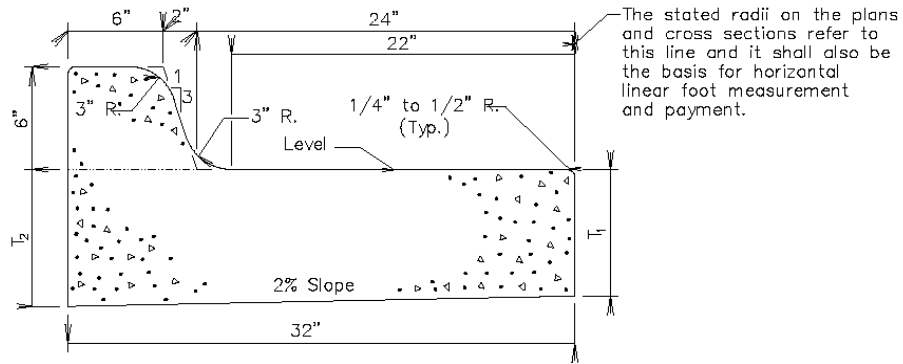

Type	T <sub>1</sub> (Inches)	T <sub>2</sub> (Inches)	Cu. Yd. Per Lin. Ft.	Lin. Ft. Per Cu. Yd.
BL66	6	65/8	0.063	15.9
BL67	7	75/8	0.071	14.1
BL68	8	85/8	0.080	12.5
BL68.5	8.5	91/8	0.084	11.9
BL69	9	95/8	0.088	11.4
BL69.5	9.5	101/8	0.092	10.9
BL610	10	105/8	0.096	10.4
BL610.5	10.5	111/8	0.100	10.0
BL611	11	115/8	0.104	9.6
BL611.5	11.5	121/8	0.108	9.3
BL612	12	125/8	0.112	8.9

**GENERAL NOTES:**

When concrete curb and gutter longitudinally adjoins new concrete pavement, the method of attachment shall be by one of the methods shown on Standard Plate 380.11.

See Standard Plate 650.90 for expansion and contraction joints in the curb and gutter.

**CURB AND GUTTER-CONCRETE-TYPE BL**

NOT TO SCALE

**CITY OF BOX ELDER**  
**STANDARD DETAIL**  
**CURB & GUTTER-TYPE BL**



DETAIL #RG002

REVISED 01/2020

# DETAIL RG003-CURB & GUTTER-TAPER

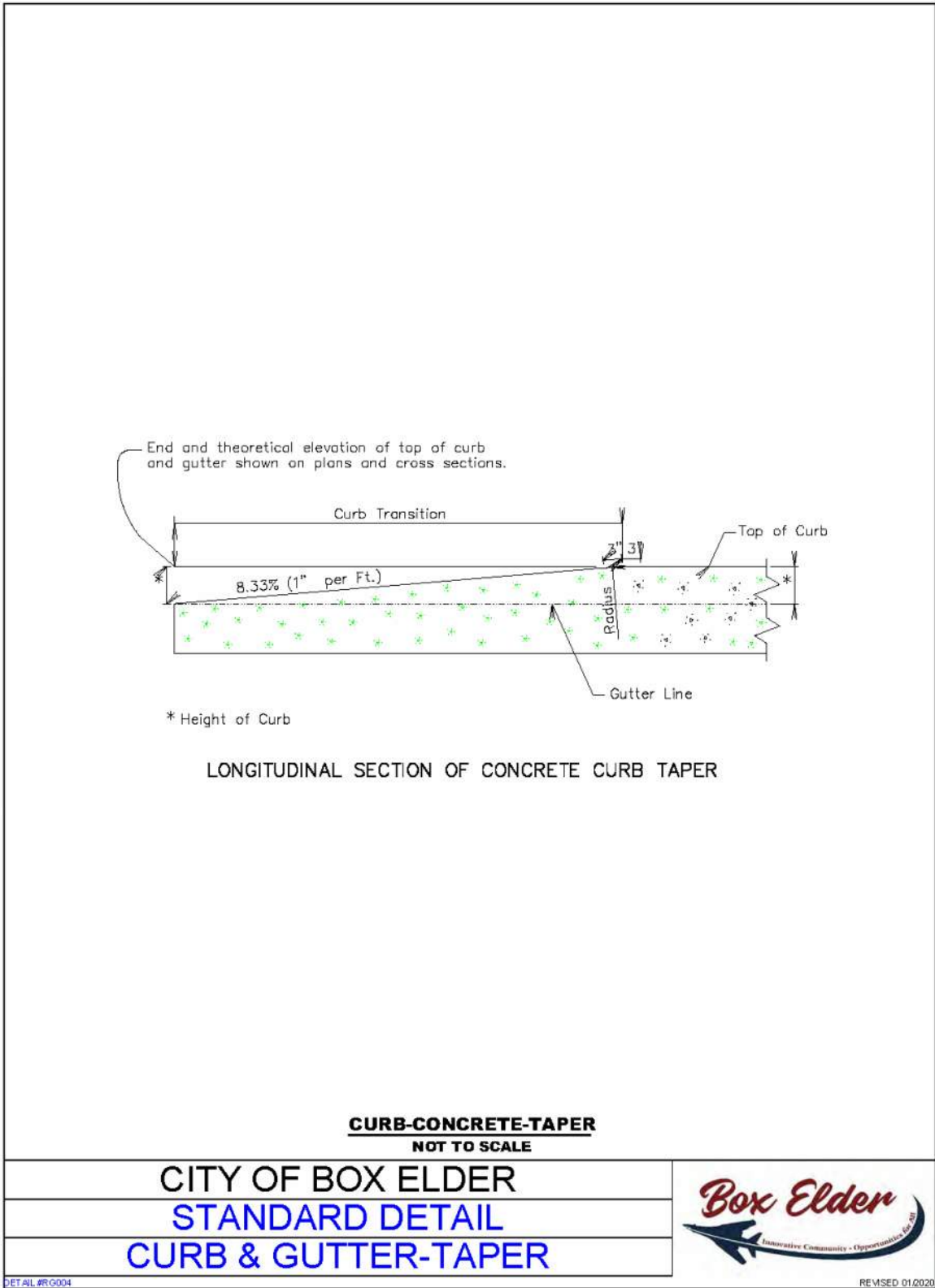

## DETAIL RG004-CURB & GUTTER-TYPE P

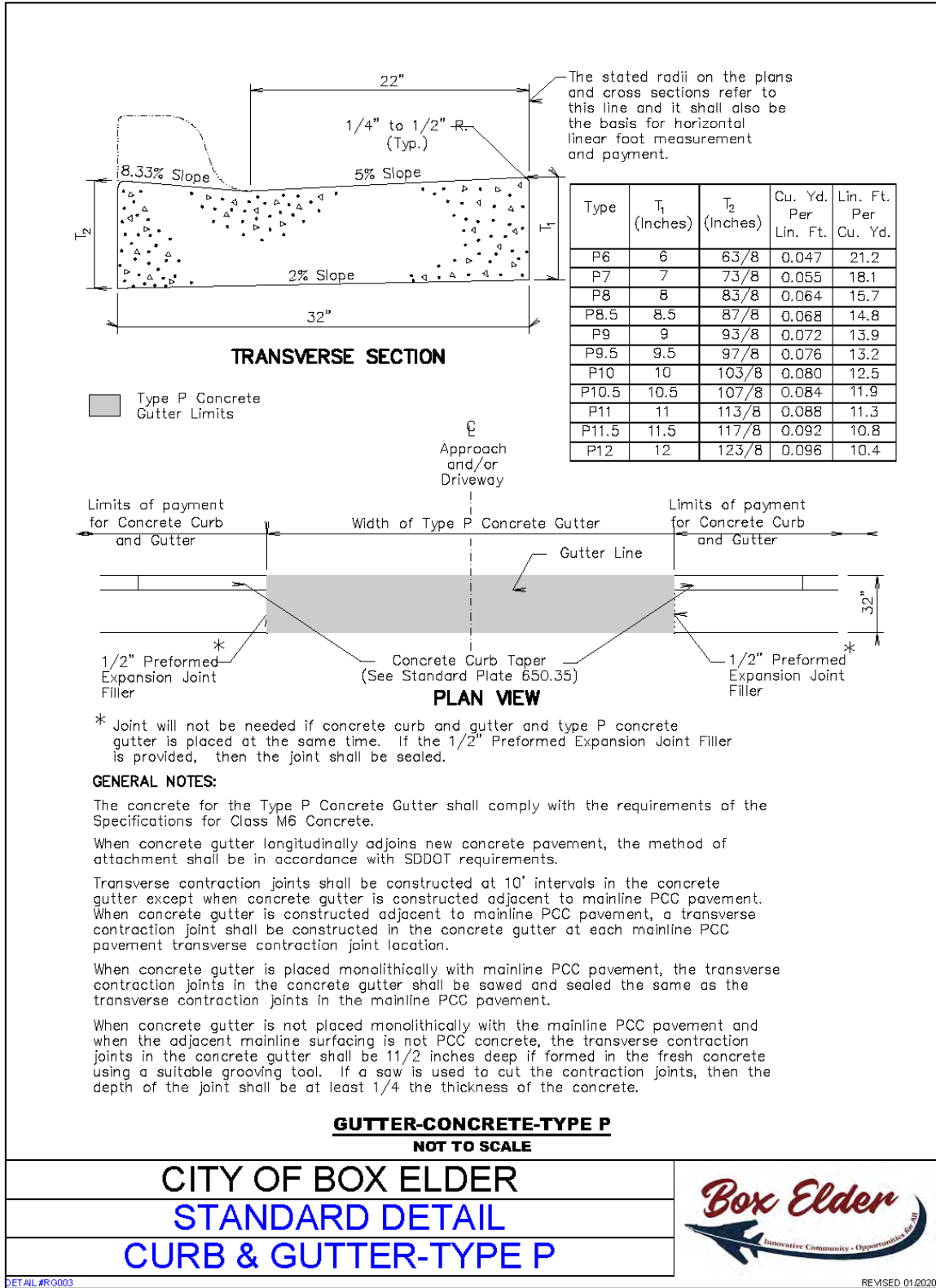

## DETAIL RG005-CURB & GUTTER-VALLEY

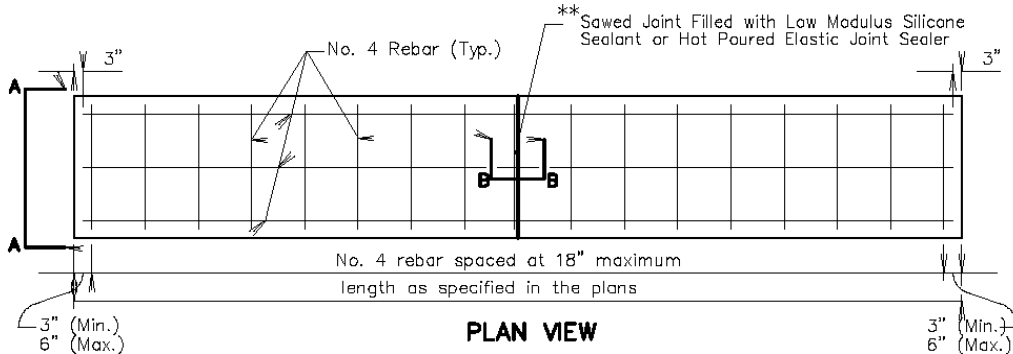

\* or as specified in the plans

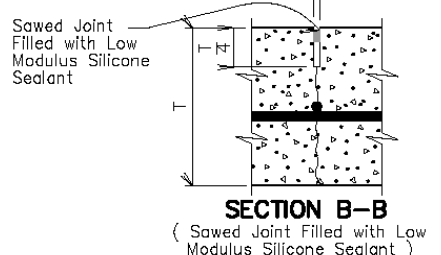
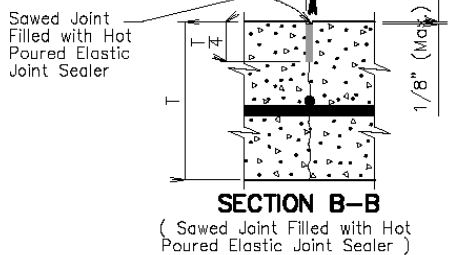
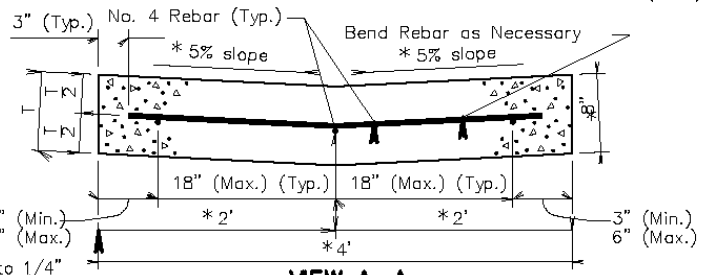

**GENERAL NOTES:**

- The concrete shall comply with the Specifications for Class M6 concrete.
- The reinforcing steel shall comply with the requirements of the Specifications.
- If a lap splice is provided the No. 4 rebar shall be lapped a minimum of 12".
- \*\* The sawed joints shall be spaced at 12'; however, when the length of the valley gutter is 12' to 24' there shall be a joint at the midpoint of the length. The saw cut to control cracking shall be a minimum of 1/4 the thickness of the pavement.
- All hot poured elastic joint sealer material spilled on the surface of the concrete pavement shall be removed as soon as the material has cooled. The extent of removal of material shall be to the satisfaction of the Engineer. All costs for removal of the spilled joint sealer material shall be borne by the Contractor.
- The silicone sealant shall be bonded to the sides of a clean joint to completely seal the joint as approved by the Engineer.

**GUTTER-CONCRETE-VALLEY**  
NOT TO SCALE

**CITY OF BOX ELDER**  
**STANDARD DETAIL**  
**CURB & GUTTER-VALLEY**



DETAIL #RG005

REVISED 01.2020

## DETAIL RG006-CURB & GUTTER-JOINTS-1

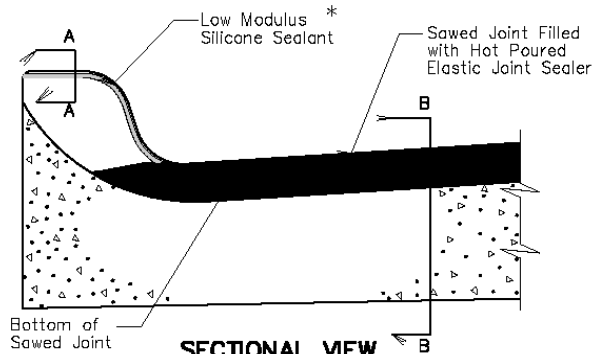

( Curb and Gutter Placed Monolithic with  
Adjacent Mainline PCC Pavement )

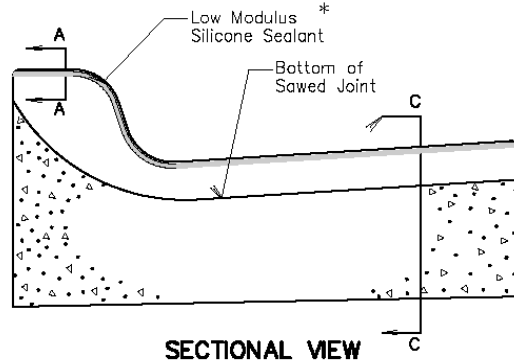
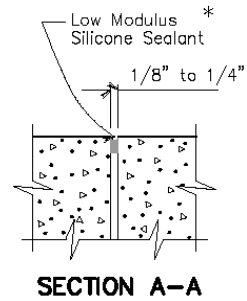

( Curb and Gutter not Placed Monolithic with  
Adjacent Mainline PCC Pavement or Mainline  
Surfacing is not PCC Pavement )

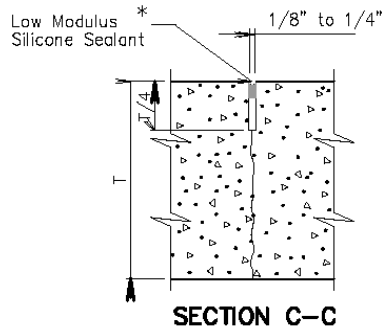
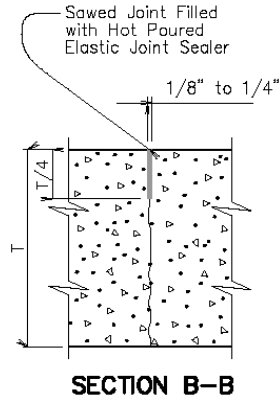

\* The silicone sealant shall be placed such  
that it completely seals the joint and is  
bonded to the sides of the clean joint  
as approved by the Engineer.

### **CURB AND GUTTER-CONCRETE-JOINTS NOT TO SCALE**

**CITY OF BOX ELDER**  
**STANDARD DETAIL**  
**CURB & GUTTER-JOINTS 1**



DETAIL #RG006

REVISED 01/2020

## DETAIL RG007-CURB & GUTTER-JOINTS-2

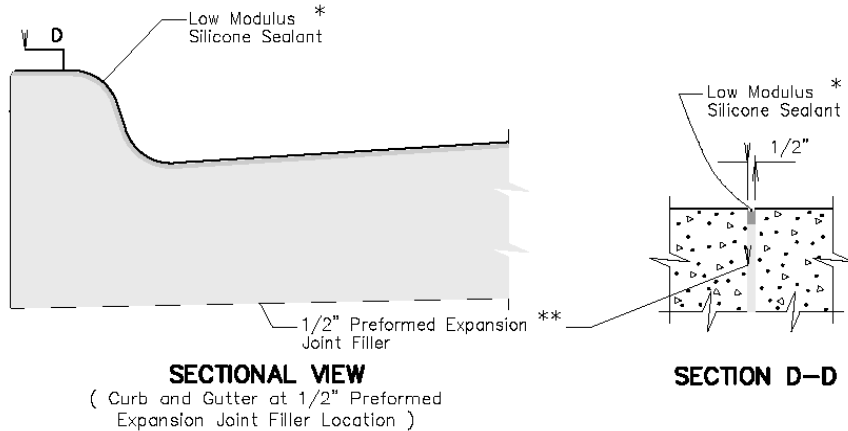

\* The silicone sealant shall be placed such that it completely seals the joint and is bonded to the sides of the clean joint as approved by the Engineer.

### GENERAL NOTES:

For illustrative reason, only the type B curb and gutter is shown.

\*\* A 1/2" preformed expansion joint filler shall be placed transversely in the curb and gutter at the following locations:

1. At each junction between the radius return of curb and gutter and curb and gutter which is parallel to the project centerline.
2. At each junction between new curb and gutter and existing curb and gutter.

Transverse contraction joints shall be constructed at 10' intervals in the concrete curb and gutter except when the concrete curb and gutter is constructed adjacent to mainline PCC pavement. When concrete curb and gutter is constructed adjacent to mainline PCC pavement, a transverse contraction joint shall be constructed in the concrete curb and gutter at each mainline PCC pavement transverse contraction joint location.

When concrete curb and gutter is not placed monolithically with the mainline PCC pavement or when the adjacent mainline surfacing is not PCC concrete, the transverse contraction joints in the concrete curb and gutter shall be 1 1/2 inches deep if formed in the fresh concrete using a suitable grooving tool. If a saw is used to cut the contraction joints, then the depth of the joint shall be at least 1/4 the thickness of the concrete and the joint shall be sealed in accordance with the details shown above.

### CURB AND GUTTER-CONCRETE-JOINTS

NOT TO SCALE

**CITY OF BOX ELDER**  
**STANDARD DETAIL**  
**CURB & GUTTER-JOINTS 2**



DETAIL #RG007

REVISED 01/2020

# DETAIL RG010-CURB & GUTTER-CURB RAMP-PERPENDICULAR-1

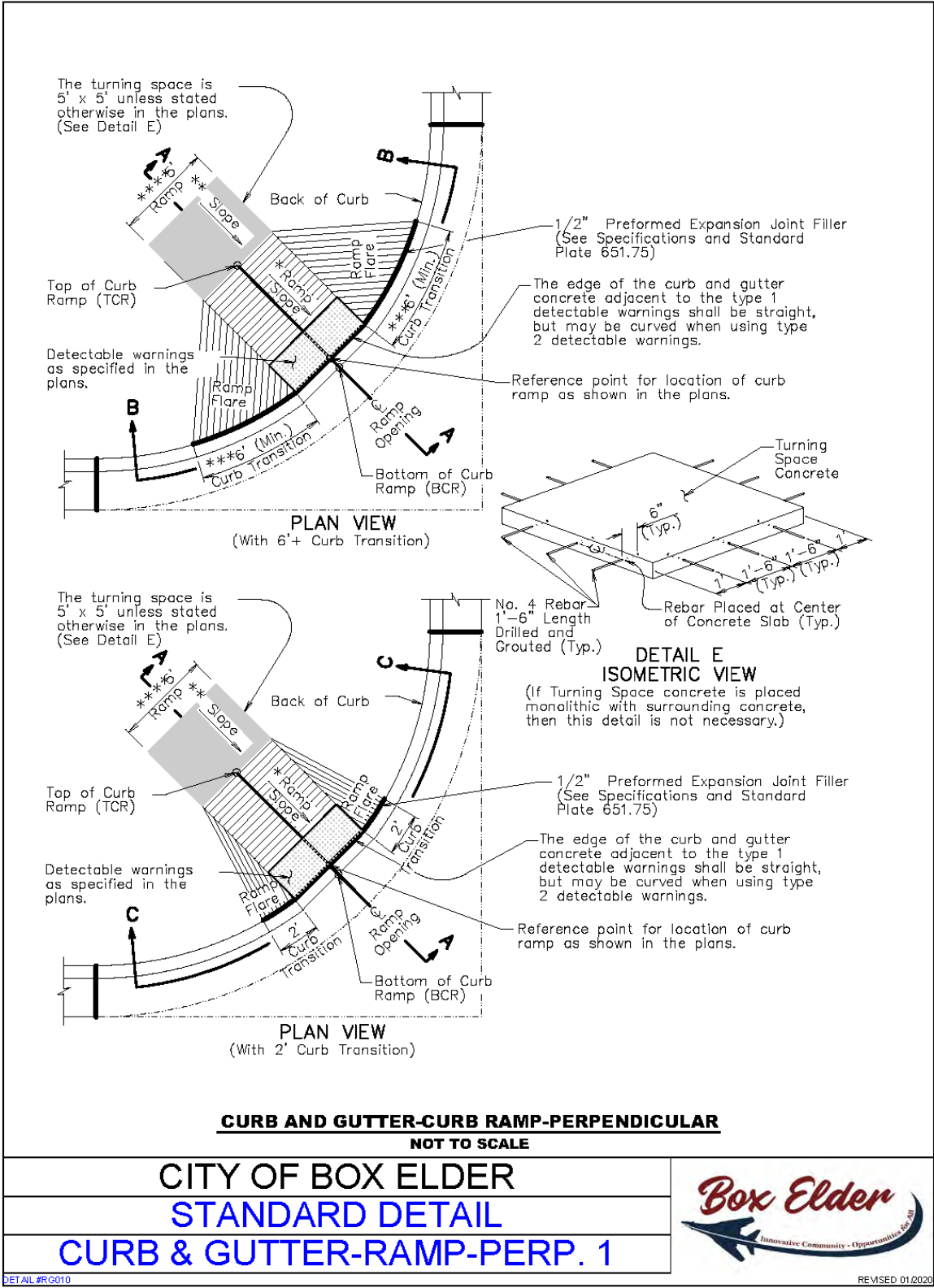



## DETAIL RG011-CURB & GUTTER-CURB RAMP-PERPENDICULAR-2

Curb ramp slopes are designed at 7.5% unless stated otherwise in the plans. The curb ramp may have a maximum slope of 8.3% and shall not exceed 15' in length unless stated otherwise in the plans.

\* The curb ramp length may be computed based on the intersection of a continuous 1.5% theoretical slope from theoretical top of curb (TTOC) with the curb ramp using a continuous 7.5% curb ramp slope. The elevation of point TCR shall always be higher than the elevation of point TTOC unless specified otherwise in the plans. The curb ramp length dimension as shown in the plans shall be adjusted as necessary to meet all slope and length requirements based on field geometrics.

The cross slope of the ramp shall not be steeper than 2%. Plans are designed using a 1.5% slope unless stated otherwise in the plans.

\*\* The slope in the turning space shall not be steeper than 2% in any direction of pedestrian travel. Plans are designed using a 1.5% slope unless stated otherwise in the plans.

\*\*\* The curb transition shall be a minimum of 6' long, a maximum of 10' long, and the curb transition slope shall not be steeper than 10% unless stated otherwise in the plans. The curb transition length shall be adjusted as necessary to meet slope and length requirements based on field geometrics.

\*\*\*\* The ramp width is 5' unless stated otherwise in the plans.

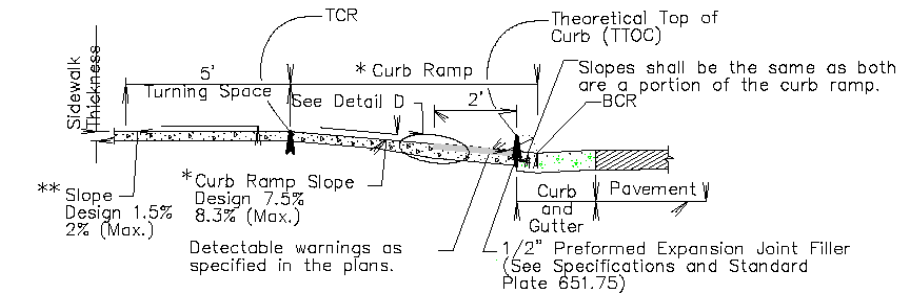

SECTION A-A

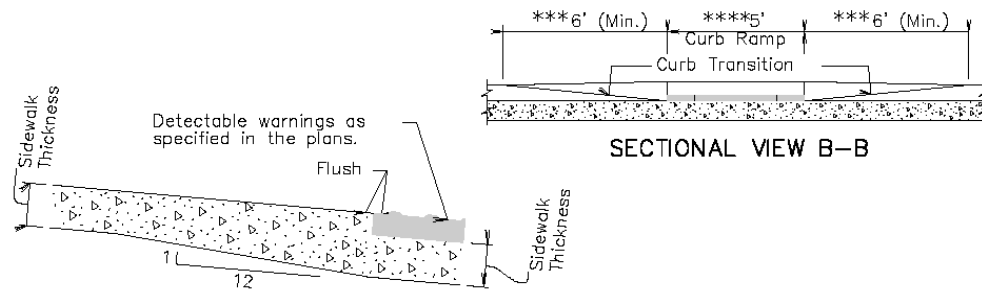

SECTIONAL VIEW B-B

DETAIL D

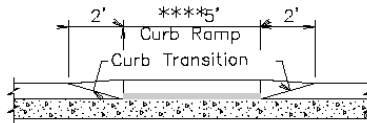

SECTIONAL VIEW C-C

**CURB AND GUTTER-CURB RAMP-PERPENDICULAR**  
NOT TO SCALE

**CITY OF BOX ELDER**  
**STANDARD DETAIL**  
**CURB & GUTTER-RAMP-PERP. 2**



DETAIL #RG011

REVISED 01/2020

# DETAIL RG012-CURB & GUTTER-CURB RAMP-PERPENDICULAR-3

## GENERAL NOTES:

For illustrative purpose only, type 1 detectable warnings are shown in the drawings.

For illustrative purpose only, PCC fillet sections are shown in the drawings. The curb ramp depicted on this standard plate may be used with a PCC fillet section or curb and gutter.

For illustrative purpose only, the curb ramp location is shown at the center of a PCC fillet section. The curb ramp shall be placed at the location stated in the plans.

Sidewalk shall not be placed adjacent to the curb ramp flares when a 2' curb transition is used unless shown otherwise in the plans.

\* Care shall be taken to ensure a uniform grade on the curb ramp, free of sags and short grade changes.

Surface texture of the curb ramp shall be obtained by coarse brooming transverse to the slope of the curb ramp.

The normal gutter line profile shall be maintained through the area of the ramp opening.

Joints shall be sawed or tooled into the concrete adjacent to the detectable warnings to alleviate possible corner cracking.

Care shall be taken to ensure that the surface of the detectable warnings are clean and maintains a uniform color.

The detectable warnings shall be cut as necessary to fit the plan specified limits of the detectable warnings. Cost for cutting the detectable warnings shall be incidental to the corresponding detectable warning bid item.

There will be no separate payment for curb ramps. The curb ramp shall be measured and paid for at the contract unit price per square foot for the corresponding concrete sidewalk bid item. The square foot area of the detectable warnings shall be included in the measured and paid for quantity of sidewalk.

If rebar is placed in the Turning Space as depicted in DETAIL E, the cost of the materials, labor, and equipment to furnish and install the rebar shall be incidental to the contract unit price per square foot for the corresponding concrete sidewalk bid item.

The curb transitions and ramp opening shall be measured and paid for at the contract unit price per foot for the corresponding curb and gutter bid item when curb and gutter is used. The curb transitions and ramp opening shall be measured and paid for at the contract unit price per square yard for the corresponding PCC fillet section bid item when a PCC fillet section is used.

The type 1 detectable warnings shall be measured to the nearest square foot. All costs for furnishing and installing the type 1 detectable warnings including labor, equipment, materials, and incidentals shall be paid for at the contract unit price per square foot for "Type 1 Detectable Warnings".

The type 2 detectable warnings shall be measured to the nearest square foot. All costs for furnishing and installing the type 2 detectable warnings including labor, equipment, and materials, including adhesive, necessary sealant or grout, and necessary grinding shall be paid for at the contract unit price per square foot for "Type 2 Detectable Warnings".

## **CURB AND GUTTER-CURB RAMP-PERPENDICULAR**

**NOT TO SCALE**

**CITY OF BOX ELDER**

**STANDARD DETAIL**

**CURB & GUTTER-RAMP-PERP. 3**



DETAIL #RG012

REVISED 01/2020

# DETAIL RG013-CURB & GUTTER-CURB RAMP-DIRECTIONAL-1

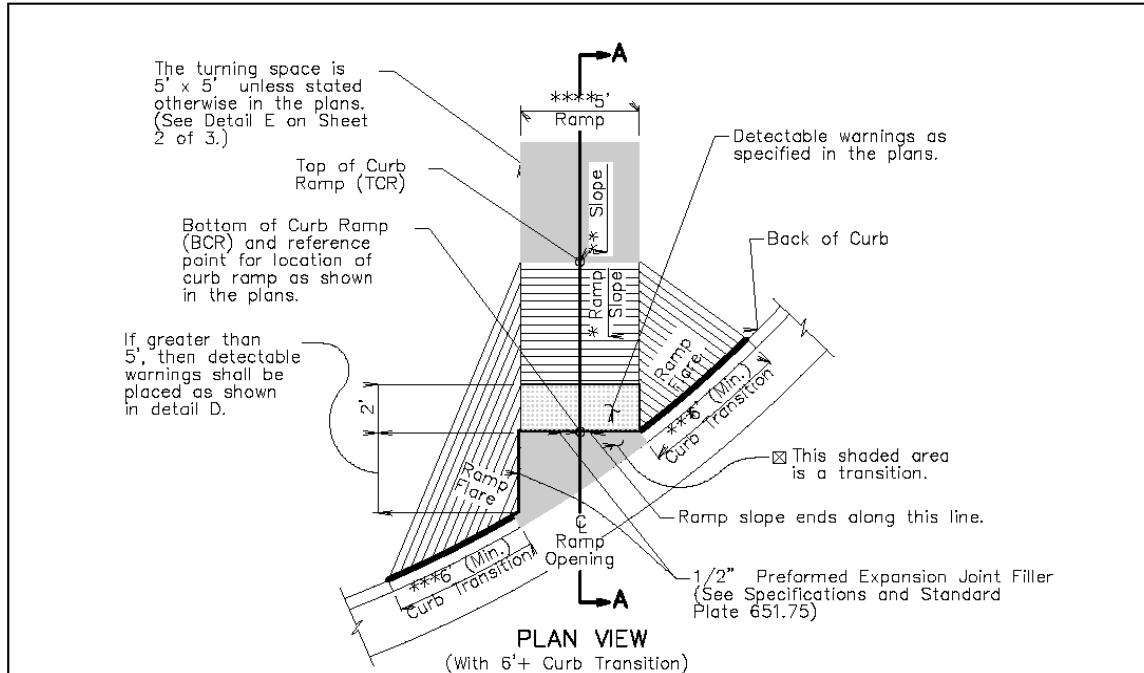

- ☒ The slope within the transition area shall not be steeper than 5%. The concrete within the transition shall be placed monolithic with the curb and gutter or fillet section concrete. The concrete thickness within the transition shall be the same as the curb and gutter or fillet section concrete thickness.
- \*\*\* The curb transition shall be a minimum of 6' long, a maximum of 10' long, and the curb transition slope shall not be steeper than 10% unless stated otherwise in the plans. The curb transition length shall be adjusted as necessary to meet slope and length requirements based on field geometrics.

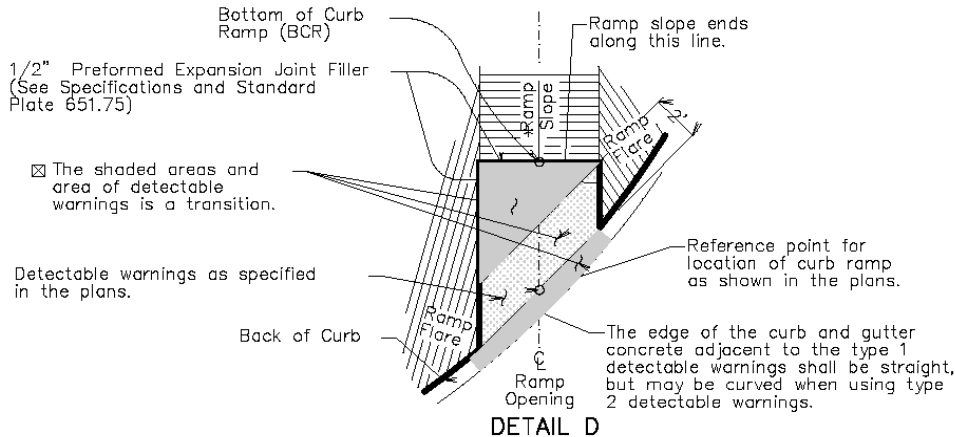

**CURB AND GUTTER-CURB RAMP-DIRECTIONAL**  
**NOT TO SCALE**

<p><b>CITY OF BOX ELDER</b></p> <p><b>STANDARD DETAIL</b></p> <p><b>CURB &amp; GUTTER-RAMP-DIRECT. 1</b></p>
--



DETAIL #RG013

REVISED 01/2020

## DETAIL RG014-CURB & GUTTER-CURB RAMP-DIRECTIONAL-2

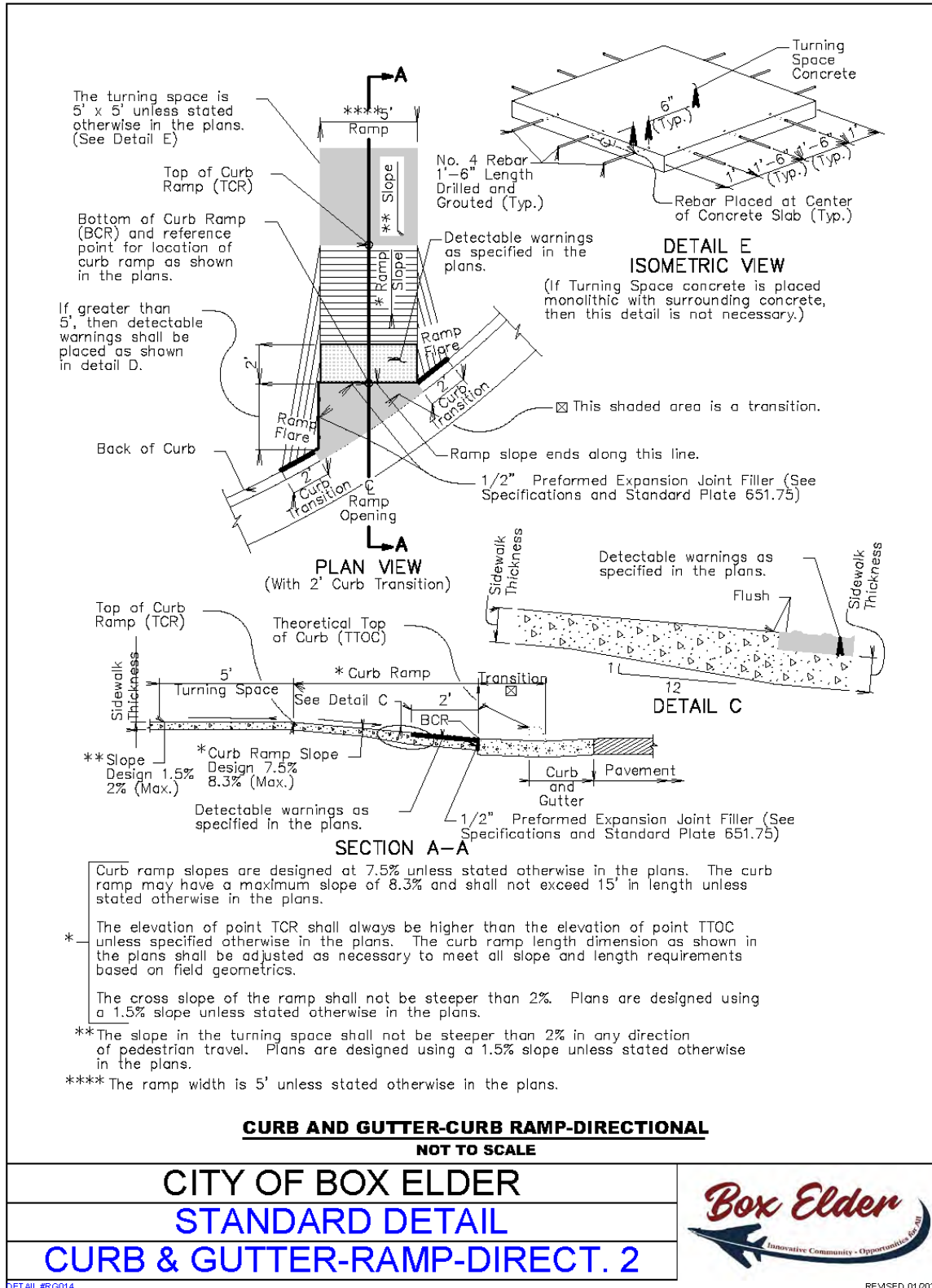

## DETAIL RG015-CURB & GUTTER-CURB RAMP-DIRECTIONAL-3

### GENERAL NOTES:

For illustrative purpose only, type 1 detectable warnings are shown in the drawings.

The curb ramp depicted on this standard plate may be used with a PCC fillet section or curb and gutter. The curb ramp shall be placed at the location stated in the plans.

Sidewalk shall not be placed adjacent to the curb ramp flares when a 2' curb transition is used unless shown otherwise in the plans.

- \* Care shall be taken to ensure a uniform grade on the curb ramp, free of sags and short grade changes.

Surface texture of the curb ramp shall be obtained by coarse brooming transverse to the slope of the curb ramp.

The normal gutter line profile shall be maintained through the area of the ramp opening.

Joints shall be sawed or tooled into the concrete adjacent to the detectable warnings to alleviate possible corner cracking.

Care shall be taken to ensure that the surface of the detectable warnings are clean and maintains a uniform color.

The detectable warnings shall be cut as necessary to fit the plan specified limits of the detectable warnings. Cost for cutting the detectable warnings shall be incidental to the corresponding detectable warning bid item.

There will be no separate payment for curb ramps. The curb ramp shall be measured and paid for at the contract unit price per square foot for the corresponding concrete sidewalk bid item. The square foot area of the detectable warnings shall be included in the measured and paid for quantity of sidewalk.

If rebar is placed in the Turning Space as depicted in DETAIL E, the cost of the materials, labor, and equipment to furnish and install the rebar shall be incidental to the contract unit price per square foot for the corresponding concrete sidewalk bid item.

The curb transitions and ramp opening shall be measured and paid for at the contract unit price per foot for the corresponding curb and gutter bid item when curb and gutter is used. The curb transitions and ramp opening shall be measured and paid for at the contract unit price per square yard for the corresponding PCC fillet section bid item when a PCC fillet section is used.

All costs for furnishing and installing the transition area at the base of the curb ramp shall be incidental to the contract unit price per foot for the corresponding curb and gutter bid item when curb and gutter is used and shall be incidental to the contract unit price per square yard for the corresponding PCC fillet section bid item when a PCC fillet section is used.

The type 1 detectable warnings shall be measured to the nearest square foot. All costs for furnishing and installing the type 1 detectable warnings including labor, equipment, materials, and incidentals shall be paid for at the contract unit price per square foot for "Type 1 Detectable Warnings".

The type 2 detectable warnings shall be measured to the nearest square foot. All costs for furnishing and installing the type 2 detectable warnings including labor, equipment, and materials, including adhesive, necessary sealant or grout, and necessary grinding shall be paid for at the contract unit price per square foot for "Type 2 Detectable Warnings".

### **CURB AND GUTTER-CURB RAMP-DIRECTIONAL**

**NOT TO SCALE**

**CITY OF BOX ELDER**

**STANDARD DETAIL**

**CURB & GUTTER-RAMP-DIRECT. 3**



DETAIL #RG015

REVISED 01/2020

**DETAIL RG016-CURB & GUTTER-CURB RAMP-PARALLEL-1**

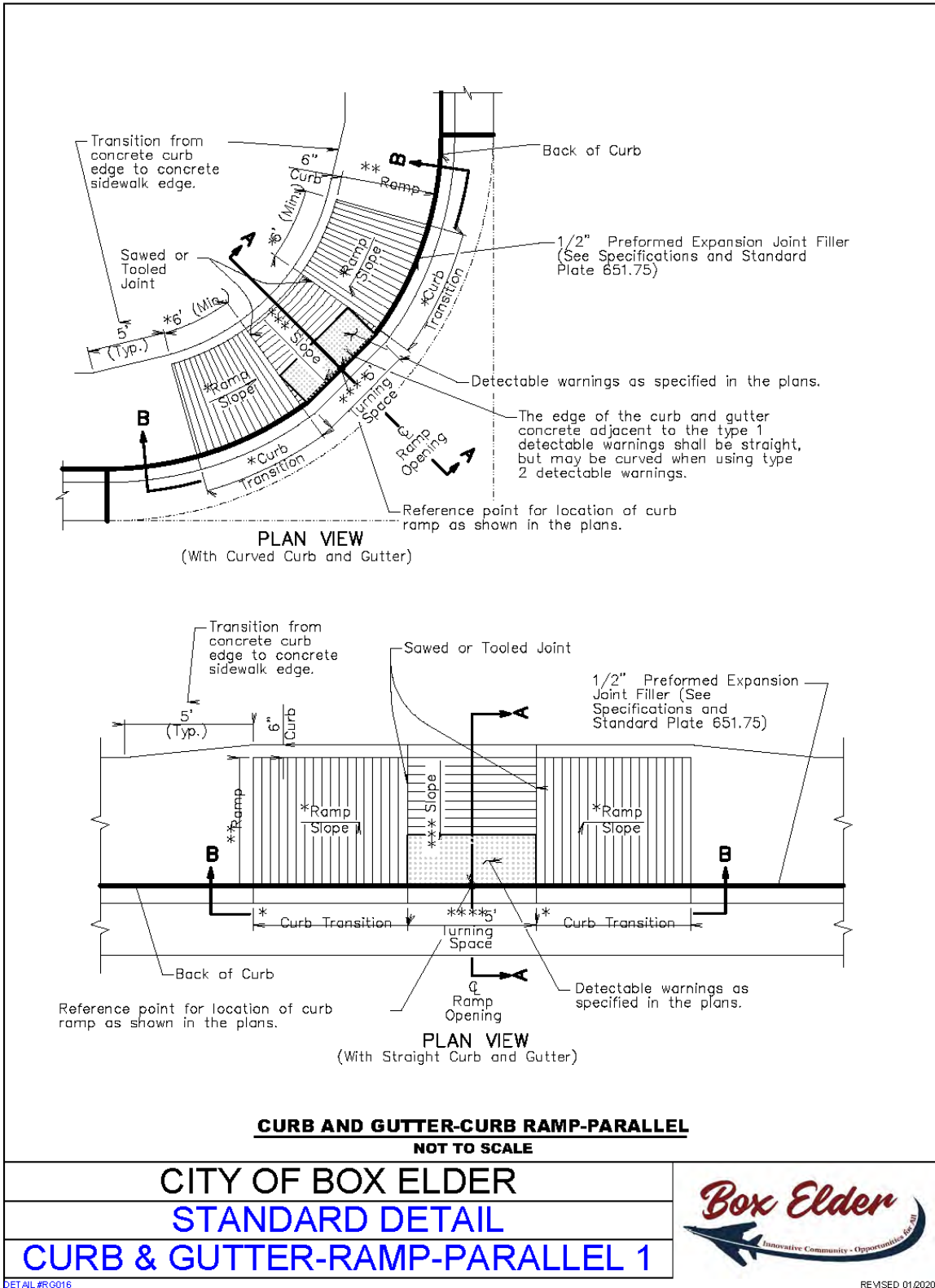

## DETAIL RG017-CURB & GUTTER-CURB RAMP-PARALLEL-2

\* The curb transition slope shall match the curb ramp slope. Curb ramp slopes are designed at 7.5% unless stated otherwise in the plans. The curb ramp may have a maximum slope of 8.3% at any location of the curb ramp and shall not exceed 15' in length unless stated otherwise in the plans. The curb transitions and curb ramp lengths shall be adjusted as necessary to meet all slope and length requirements based on field geometrics.

\*\* The cross slope of the ramp shall not be steeper than 2% and the ramp width is 5' unless stated otherwise in the plans. Plans are designed using a 1.5% cross slope for the ramp unless stated otherwise in the plans.

\*\*\* The slope in the turning space shall not be steeper than 2% in any direction of pedestrian travel. Plans are designed using a 1.5% slope unless stated otherwise in the plans.

\*\*\*\* The turning space is 5' x 5' unless stated otherwise in the plans.

☒ The curb height shall be 6" unless stated otherwise in the plans.

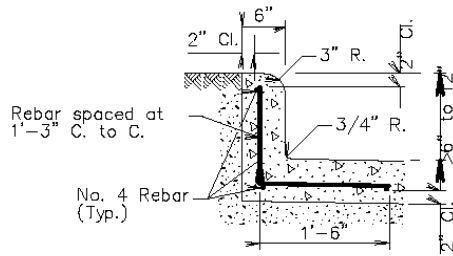
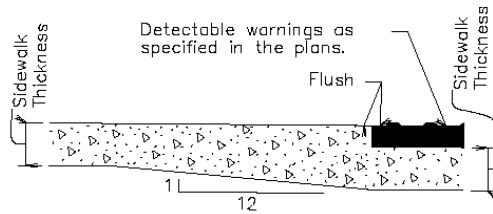
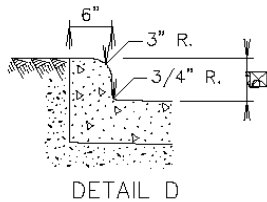
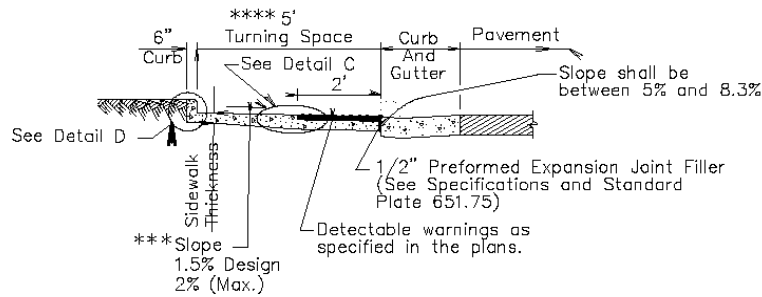

( Use this detail when the curb height is greater than 6" and less than 12" )

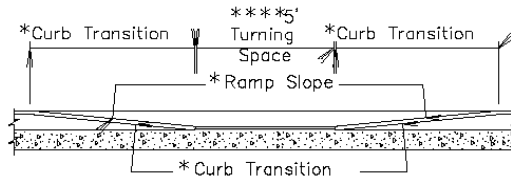

### CURB AND GUTTER-CURB RAMP-PARALLEL

NOT TO SCALE

**CITY OF BOX ELDER**  
**STANDARD DETAIL**  
**CURB & GUTTER-RAMP-PARALLEL 2**



DETAIL #RG017

REVISED 01/2020

## DETAIL RG018-CURB & GUTTER-CURB RAMP-PARALLEL-3

### GENERAL NOTES:

For illustrative purpose only, type 1 detectable warnings are shown in the drawings.

For illustrative purpose only, a PCC fillet section is shown in one of the drawings. The curb ramp depicted on this standard plate may be used with a PCC fillet section or with curb and gutter.

The curb ramp shall be placed at the location stated in the plans.

Sidewalk adjacent to the curb ramp shall be as shown in the plans.

Care shall be taken to ensure a uniform grade on the curb ramp, free of sags and short grade changes.

Surface texture of the curb ramp shall be obtained by coarse brooming transverse to the slope of the curb ramp.

The normal gutter line profile shall be maintained through the area of the ramp opening.

Joints shall be sawed or tooled into the concrete adjacent to the detectable warnings to alleviate possible corner cracking (see plan view for joint location).

Care shall be taken to ensure that the surface of the detectable warnings are clean and maintains a uniform color.

The detectable warnings shall be cut as necessary to fit the plan specified limits of the detectable warnings. Cost for cutting the detectable warnings shall be incidental to the corresponding detectable warning bid item.

When curb height is greater than 6" and less than 12", reinforcing steel is required in accordance with the detail on sheet 2 of 3. The reinforcing steel shall conform to ASTM A615, Grade 60. Cost for furnishing and installing the reinforcing steel shall be incidental to the contract unit price per square foot for the corresponding concrete sidewalk bid item.

There will be no separate payment for curb ramps. The curb ramp shall be measured and paid for at the contract unit price per square foot for the corresponding concrete sidewalk bid item. The square foot area of the detectable warnings and the curb along the short radius shall be included in the measured and paid for quantity of sidewalk.

The curb transitions and ramp opening shall be measured and paid for at the contract unit price per foot for the corresponding curb and gutter bid item when curb and gutter is used. The curb transitions and ramp opening shall be measured and paid for at the contract unit price per square yard for the corresponding PCC fillet section bid item when a PCC fillet section is used.

The type 1 detectable warnings shall be measured to the nearest square foot. All costs for furnishing and installing the type 1 detectable warnings including labor, equipment, materials, and incidentals shall be paid for at the contract unit price per square foot for "Type 1 Detectable Warnings".

The type 2 detectable warnings shall be measured to the nearest square foot. All costs for furnishing and installing the type 2 detectable warnings including labor, equipment, and materials, including adhesive, necessary sealant or grout, and necessary grinding shall be paid for at the contract unit price per square foot for "Type 2 Detectable Warnings".

### **CURB AND GUTTER-CURB RAMP-PARALLEL**

**NOT TO SCALE**

**CITY OF BOX ELDER**

**STANDARD DETAIL**

**CURB & GUTTER-RAMP-PARALLEL 3**



DETAIL #RG018

REVISED 01/2020





# DETAIL RG031-CURB & GUTTER-OPENING AND TRANSITIONS FOR FUTURE CURB RAMP-2

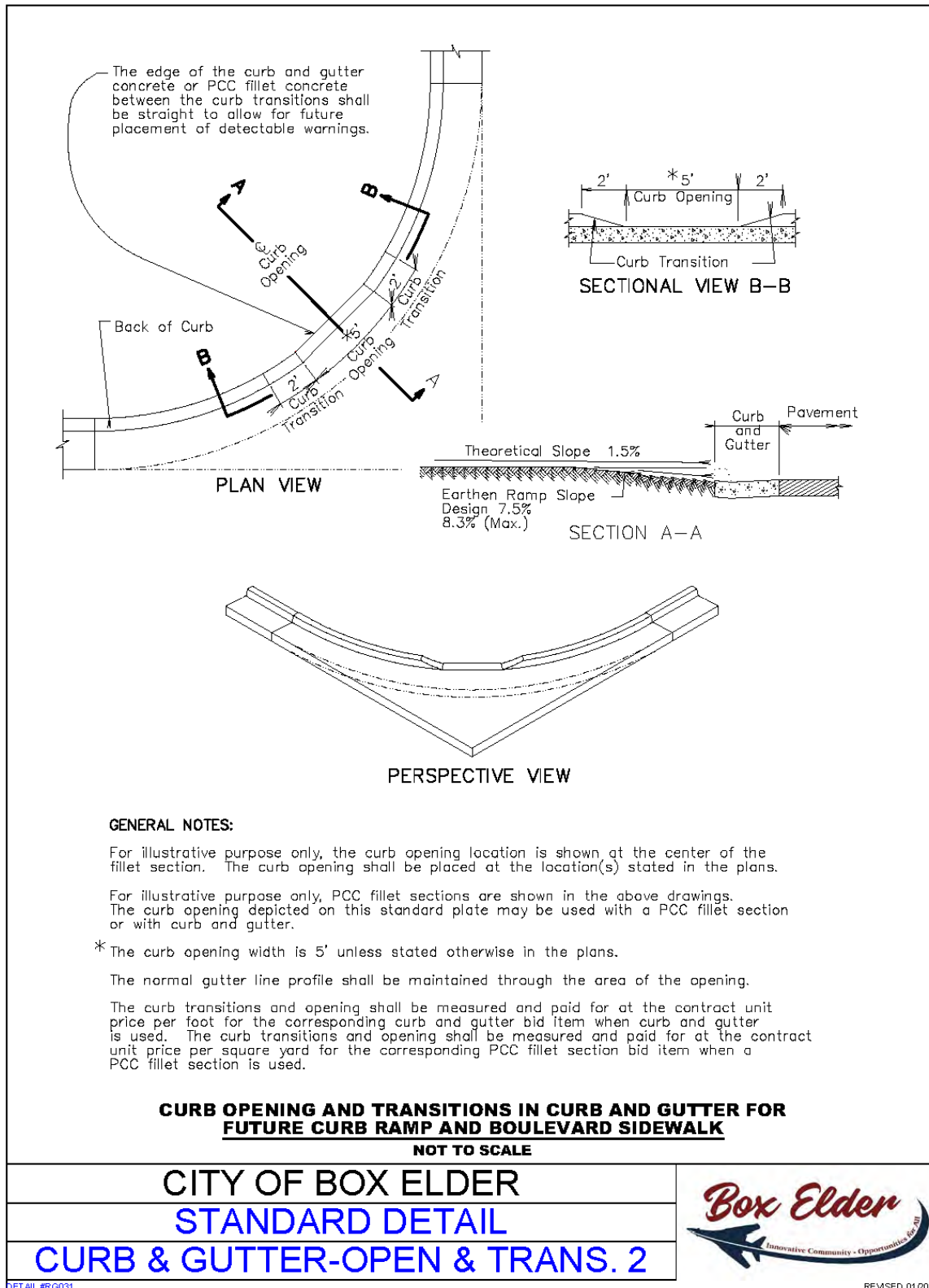

**DETAIL RL001-LIGHTING-DETECTOR LOOP-PREFORMED**

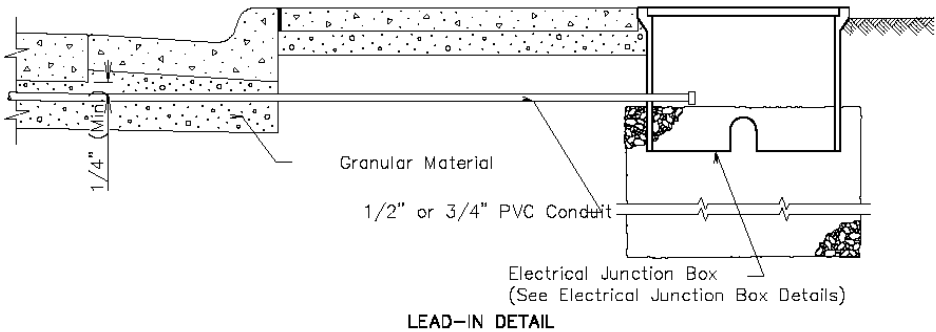
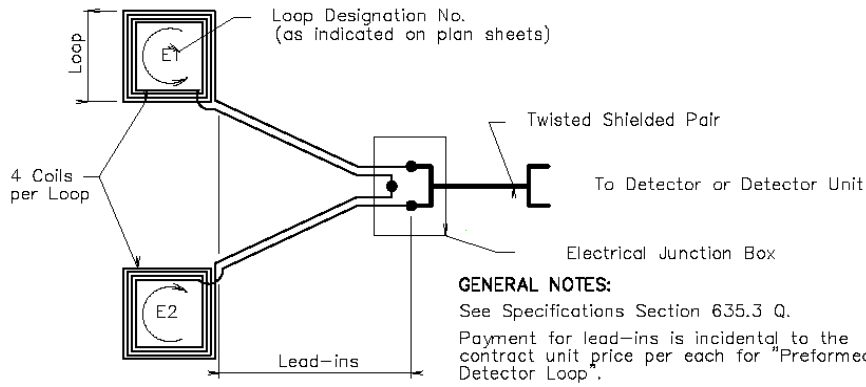
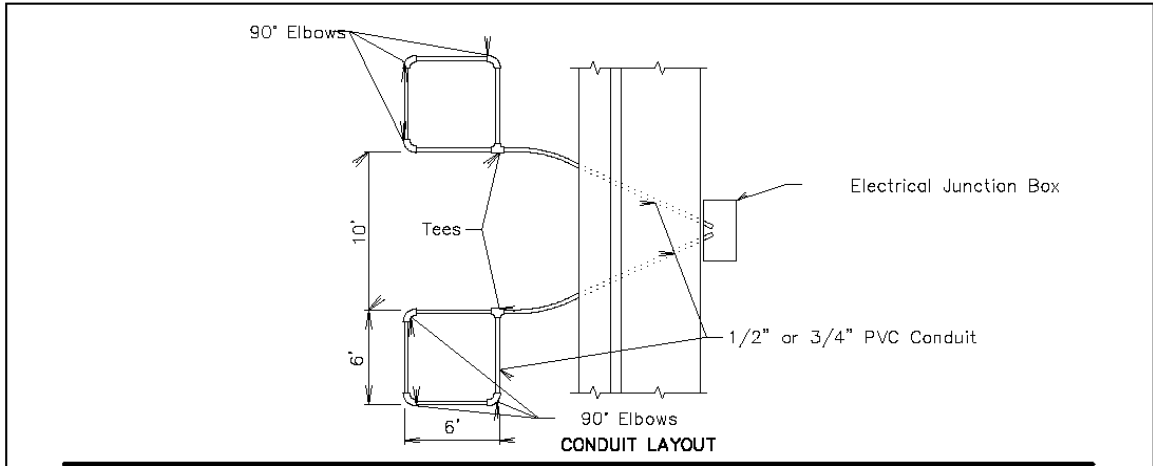

**LIGHTING-DETECTOR LOOP-PREFORMED**  
**NOT TO SCALE**

**CITY OF BOX ELDER**  
**STANDARD DETAIL**  
**LIGHTING-DETECTOR LOOP-PREFORM**



DETAIL #RL001

REVISED 01/2020

**DETAIL RL002-LIGHTING-DETECTOR LOOP-SAWED IN**

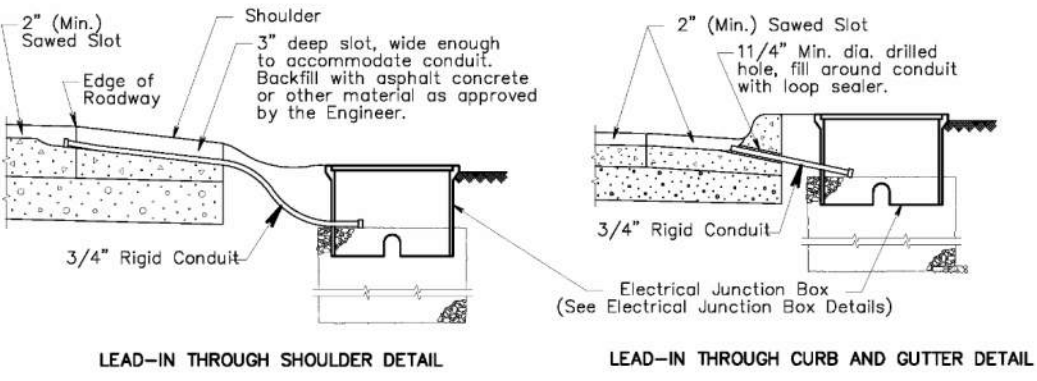
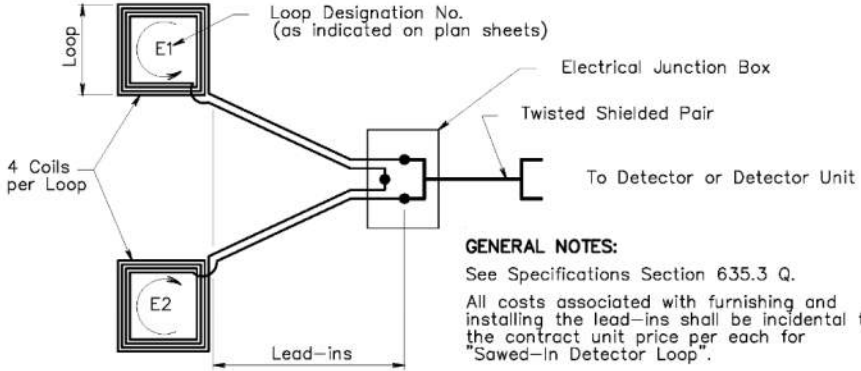
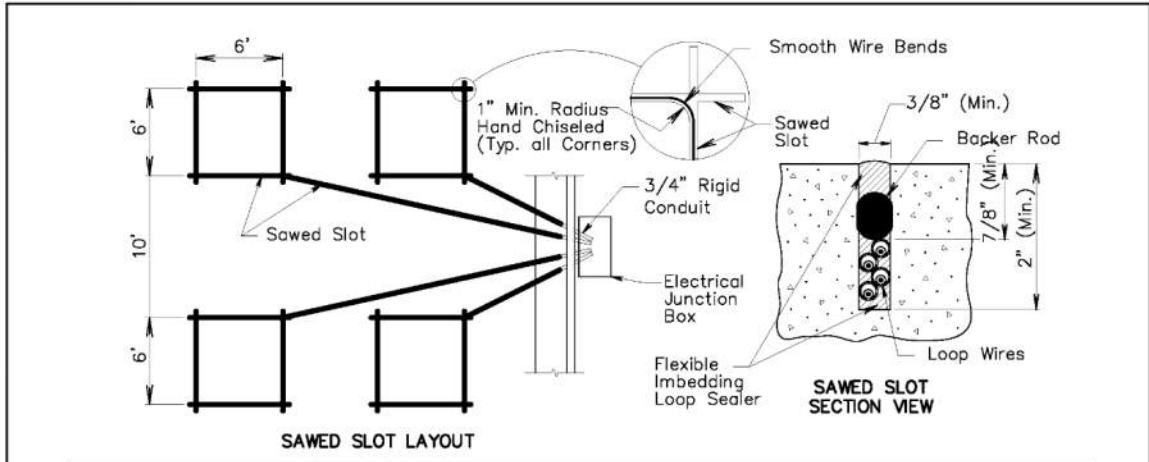

**LIGHTING-DETECTOR LOOP-SAWED-IN**  
**NOT TO SCALE**

<p><b>CITY OF BOX ELDER</b>  <b>STANDARD DETAIL</b>  <b>LIGHTING-DETECTOR LOOP-SAWED</b></p>	
DETAIL #RL002	REVISED 01/2020

**DETAIL RL003-LIGHTING-DETECTOR LOOP-SAWED IN PCC**

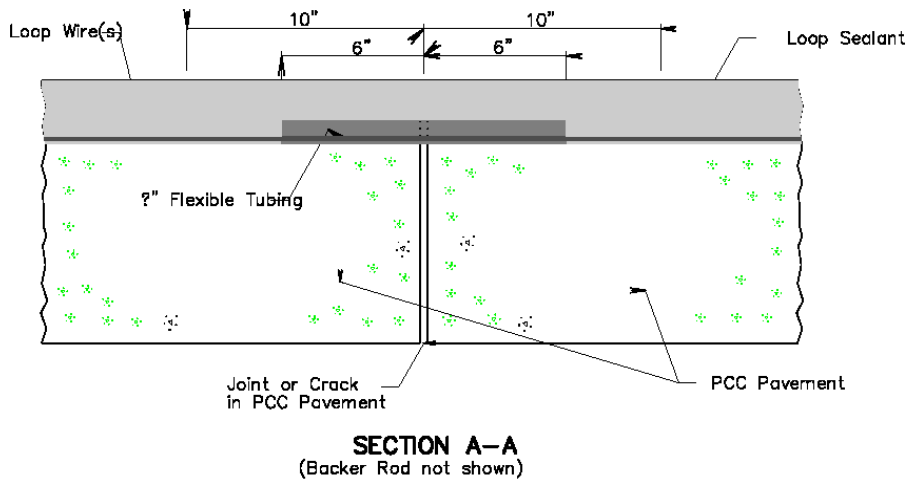
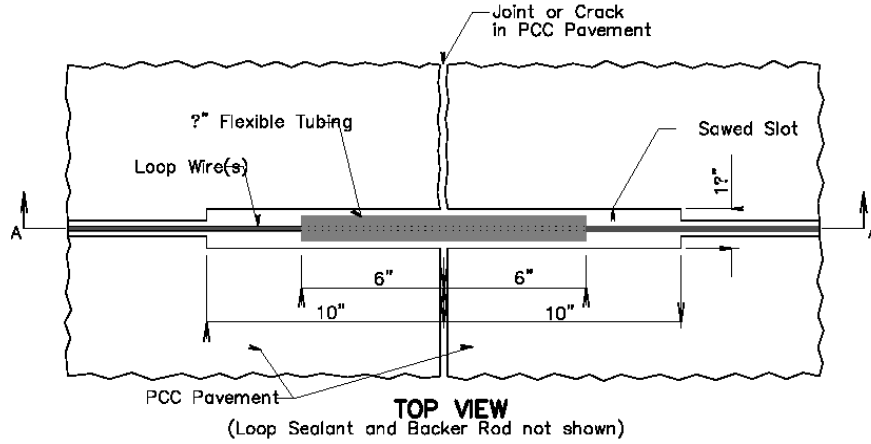

**GENERAL NOTE:**

All costs for constructing the sawed-in detector loop protection including labor, equipment, and materials shall be incidental to the contract unit price per each for "Sawed-In Detector Loop".

**LIGHTING-DETECTOR LOOP-SAWED-IN PCC**  
**NOT TO SCALE**

**CITY OF BOX ELDER**  
**STANDARD DETAIL**  
**LIGHTING-DETECTOR LOOP-SAWED**



DETAIL RL003

REVISED 01/2020

**DETAIL RL004-LIGHTING-CONDUCTOR CABLES-CONDUIT**

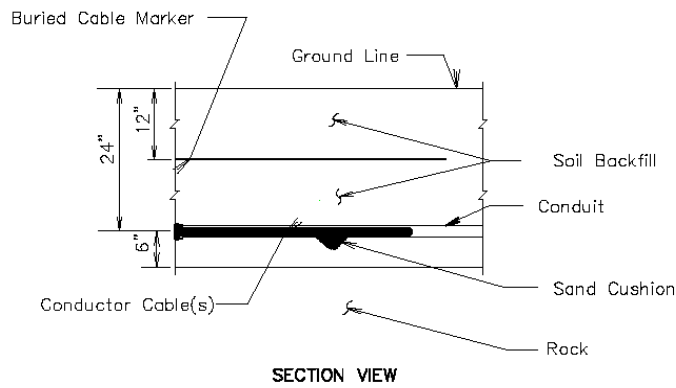
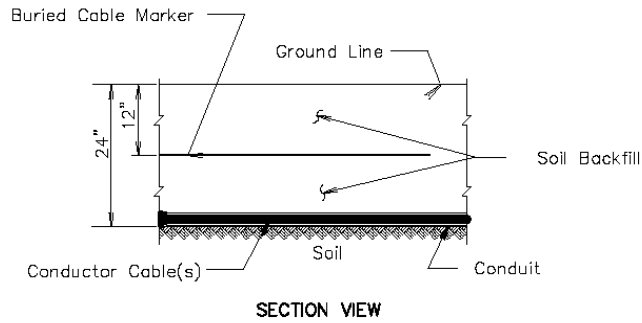

**GENERAL NOTE:**

The Buried Cable Marker shall be plastic, approximately 6" wide, and shall be capable of sustaining a minimum of a 350% tolerance of elongation without tearing. The Buried Cable Marker shall have a life expectancy approximately equal to that of the conductor(s) beneath it. A phrase indicating the presence of a buried electric circuit below shall be printed in a contrasting color on the cable marker. The Buried Cable Marker shall be subject to approval by the Engineer. All costs associated with furnishing and installing the Buried Cable Marker shall be incidental to the contract unit price per Foot for the bid item used for the electrical conductor.

**LIGHTING-CONDUCTOR CABLES-CONDUIT**  
NOT TO SCALE

**CITY OF BOX ELDER**  
**STANDARD DETAIL**  
**LIGHTING-CONDUCTOR CABLES-COND**



DETAIL #RL004

REVISED 01/2020

**DETAIL RL005-LIGHTING-CONDUCTOR CABLES-DIRECT BURY**

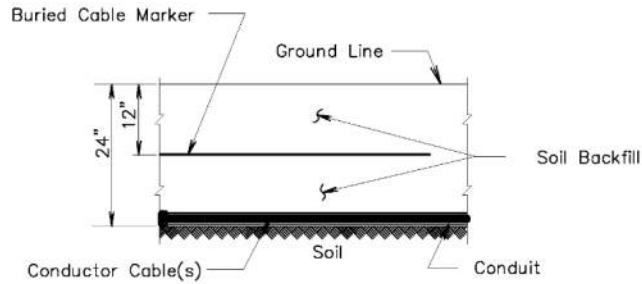

**SECTION VIEW**

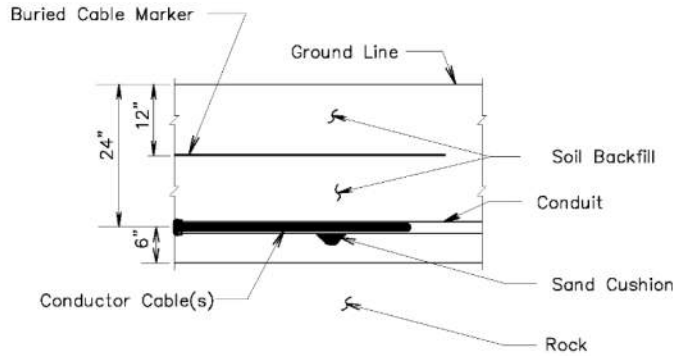

**SECTION VIEW**

**GENERAL NOTE:**

The Buried Cable Marker shall be plastic, approximately 6" wide, and shall be capable of sustaining a minimum of a 350% tolerance of elongation without tearing. The Buried Cable Marker shall have a life expectancy approximately equal to that of the conductor(s) beneath it. A phrase indicating the presence of a buried electric circuit below shall be printed in a contrasting color on the cable marker. The Buried Cable Marker shall be subject to approval by the Engineer. All costs associated with furnishing and installing the Buried Cable Marker shall be incidental to the contract unit price per Foot for the bid item used for the electrical conductor.

**LIGHTING-CONDUCTOR CABLES-CONDUIT**

**NOT TO SCALE**

**CITY OF BOX ELDER  
STANDARD DETAIL**

**LIGHTING-CONDUCTOR CABLES-CON.**



DETAIL #RL005

REVISED 01/2020

## DETAIL RR001-RAILROAD-PAVEMENT MARKINGS AT CROSSINGS

KEY	ITEM
(24 W)	24" White
X	White

Posted Speed Limit (M.P.H.)	L (Ft.)
≤ 30	100
35	100
40	125
45	175
50	250
55	325
60	400
65	475
70	550

**PLAN VIEW**

**DETAIL A**

**GENERAL NOTES:**

- The railroad crossing pavement markings will be placed symmetrically about the centerline of the railroad crossing.
- When pavement markings are used, a portion of the RXR symbol will be placed directly opposite of the advance warning sign W10-1.
- On multi-lane roads the transverse bands will extend across all approach lanes and individual RXR symbols will be placed in each approach lane.
- The railroad crossing pavement markings will consist of all the transverse bands, stop bars, and RXR symbols.
- When pavement marking paint is used for marking the railroad crossing, all costs for furnishing and painting the markings, materials, labor, and necessary equipment will be incidental to the contract unit price per gallon.
- When pavement marking tape is used for marking the railroad crossing, all costs for furnishing and placing the markings, materials, labor, and necessary equipment will be incidental to the contract unit price per each..

**RAILROAD-PAVEMENT MARKINGS AT CROSSINGS**  
NOT TO SCALE

**CITY OF BOX ELDER**

**STANDARD DETAIL**

**RAILROAD-PAVEMENT MARKINGS**

DETAIL #RR001 REVISED 01/2020



# DETAIL RR002-RAILROAD-TYPICAL APPROACH

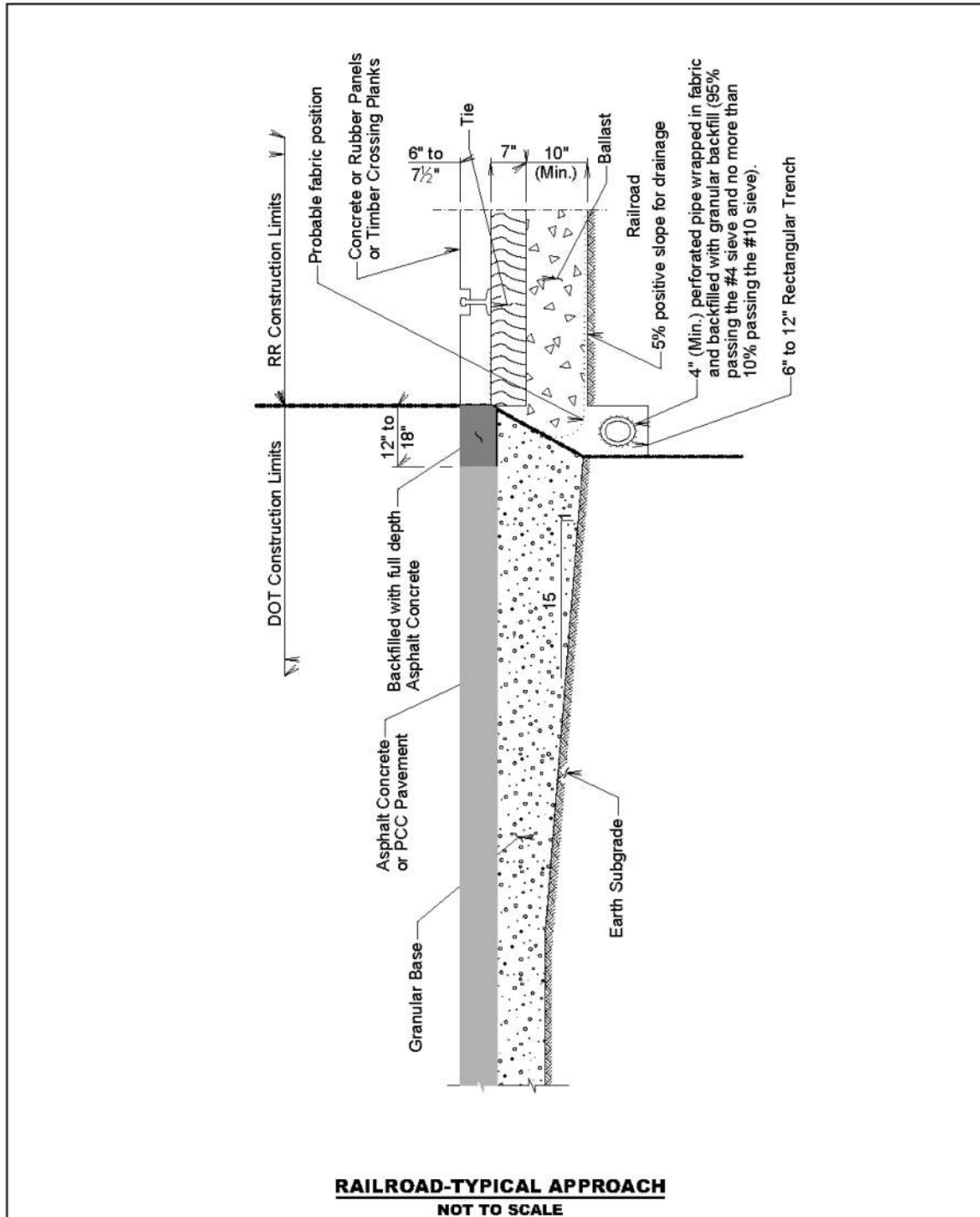

**RAILROAD-TYPICAL APPROACH**  
NOT TO SCALE

CITY OF BOX ELDER  
STANDARD DETAIL  
RAILROAD-TYPICAL APPROACH



DETAIL RR002

REVISED 01/2020

**DETAIL RR003-RAILROAD-EXCAVATION PROFLES**

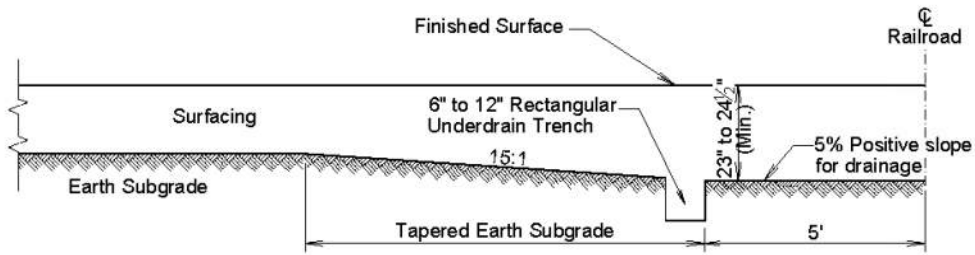

**EXCAVATION PROFILE ALONG ROADWAY**

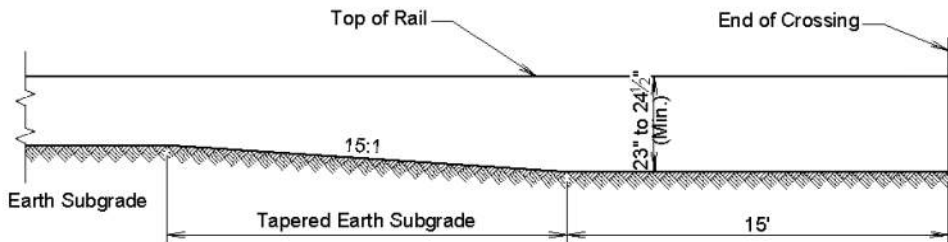

**EXCAVATION PROFILE ALONG RAILROAD**

**RAILROAD-EXCAVATION PROFILES  
NOT TO SCALE**

**CITY OF BOX ELDER  
STANDARD DETAIL  
RAILROAD-TYPICAL GRADING**



DETAIL #RR003

REVISED: 01/2020

**DETAIL RR010-RAILROAD-DETECTABLE SIDEWALK WARNINGS ADJACENT TO CROSSINGS-1**

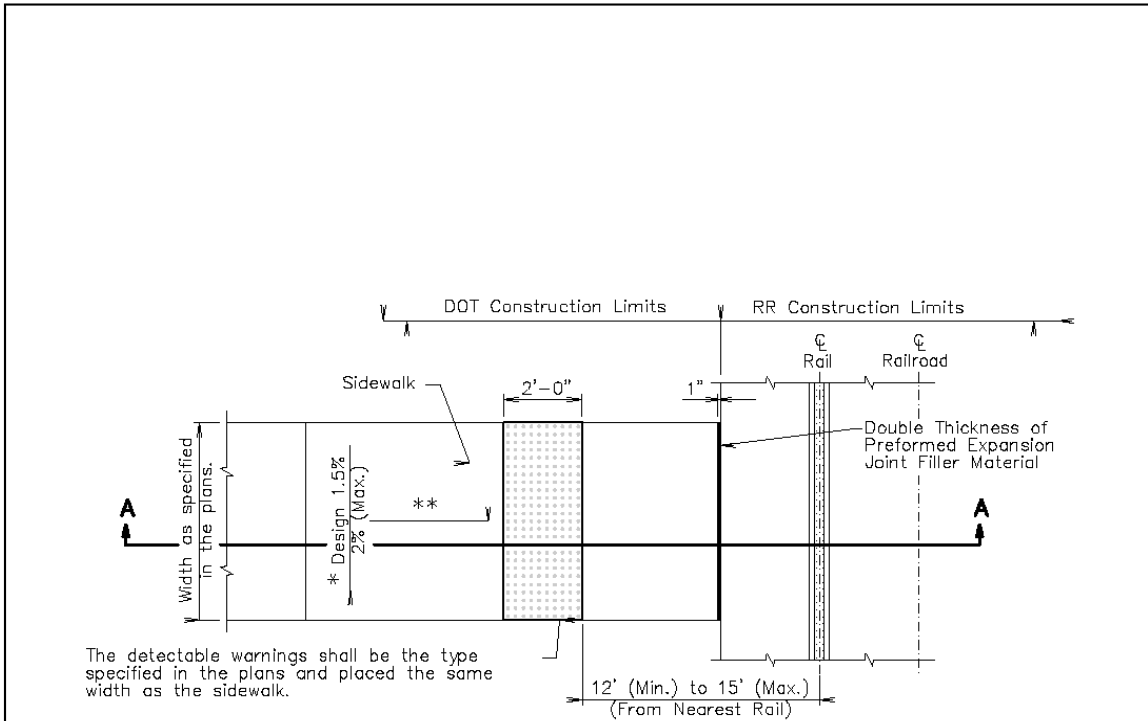

PLAN VIEW

- \* The cross slope of the sidewalk shall not be steeper than 2%. Plans are designed using a 1.5% cross slope unless stated otherwise in the plans.
- \*\* If the sidewalk is curbside, then the surface of the curbside sidewalk shall match the slope of the curb transition. The longitudinal slope of the sidewalk and curb transition, where the sidewalk transitions to the railroad crossing elevation, is designed at 4.5% and shall not be steeper than 5% unless stated otherwise in the plans.
- \*\* The longitudinal slope of the sidewalk, where the sidewalk transitions to the railroad crossing elevation, is designed at 4.5% and shall not be steeper than 5% unless stated otherwise in the plans.

**RAILROAD-DETECTABLE SIDEWALK WARNINGS ADJACENT TO CROSSINGS-1**  
NOT TO SCALE

CITY OF BOX ELDER
STANDARD DETAIL
RAILROAD-DETECTABLE SIDEWALK 1



DETAIL #RR010

REVISED 01/2020

# DETAIL RR011-RAILROAD-DETECTABLE SIDEWALK WARNINGS ADJACENT TO CROSSINGS-2

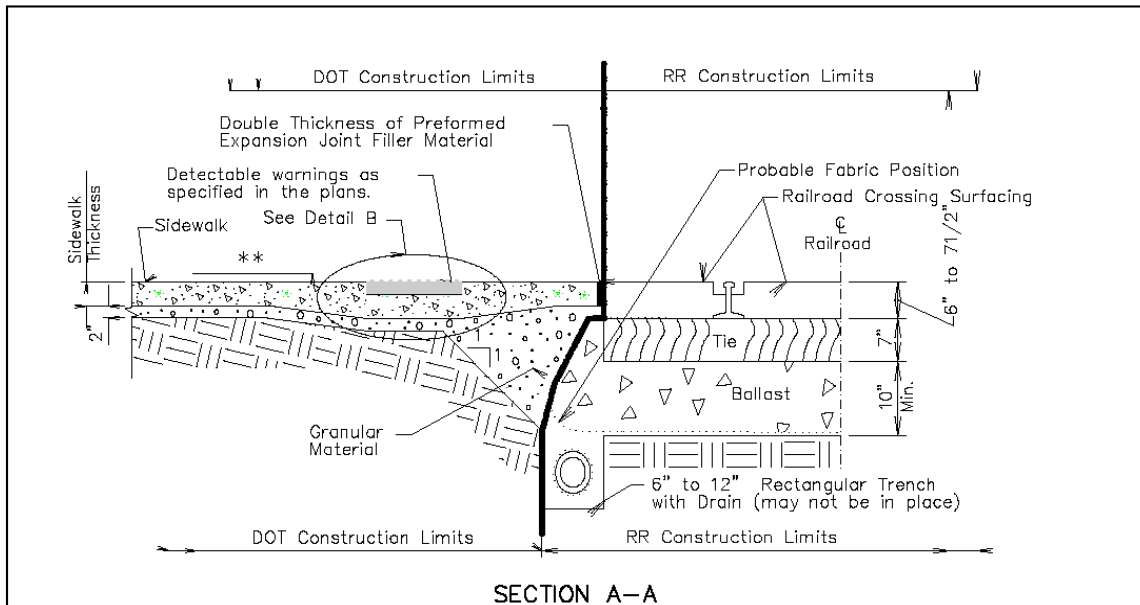

**GENERAL NOTES:**

For illustrative purpose only, type 1 detectable warnings are shown in the drawings.

Ballast material shall not be disturbed during construction work adjacent to the railroad crossing unless the adjacent work involves reconstruction or maintenance of the railroad crossing.

The sidewalk shall be placed at the location stated in the plans and shall be perpendicular to the railroad crossing.

Care shall be taken to ensure that the surface of the detectable warnings are clean and maintains a uniform color.

If curb and gutter is required adjacent to the railroad crossing, the curb transition shall be measured and paid for at the contract unit price per foot for the corresponding curb and gutter bid item.

The type 1 detectable warnings shall be measured to the nearest square foot. All costs for furnishing and installing the type 1 detectable warnings including labor, equipment, materials, and incidentals shall be paid for at the contract unit price per square foot for "Type 1 Detectable Warnings".

The type 2 detectable warnings shall be measured to the nearest square foot. All costs for furnishing and installing the type 2 detectable warnings including labor, equipment, and materials, including adhesive, necessary sealant or grout, and necessary grinding shall be paid for at the contract unit price per square foot for "Type 2 Detectable Warnings".

The square foot area of the detectable warnings shall be included in the measured and paid for quantity of sidewalk.

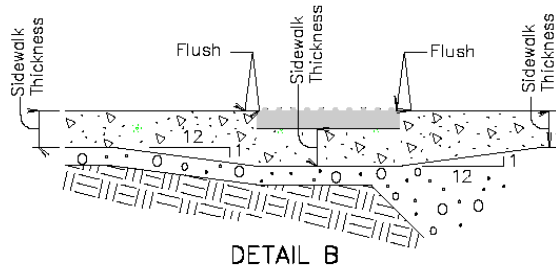

**RAILROAD-DETECTABLE SIDEWALK WARNINGS ADJACENT TO CROSSINGS 2**

**NOT TO SCALE**

**CITY OF BOX ELDER**  
**STANDARD DETAIL**  
**RAILROAD-DETECTABLE SIDEWALK 2**



DETAIL #RR011

REVISED 01/2020

# DETAIL RS001-SIDEWALK-CONCRETE-1

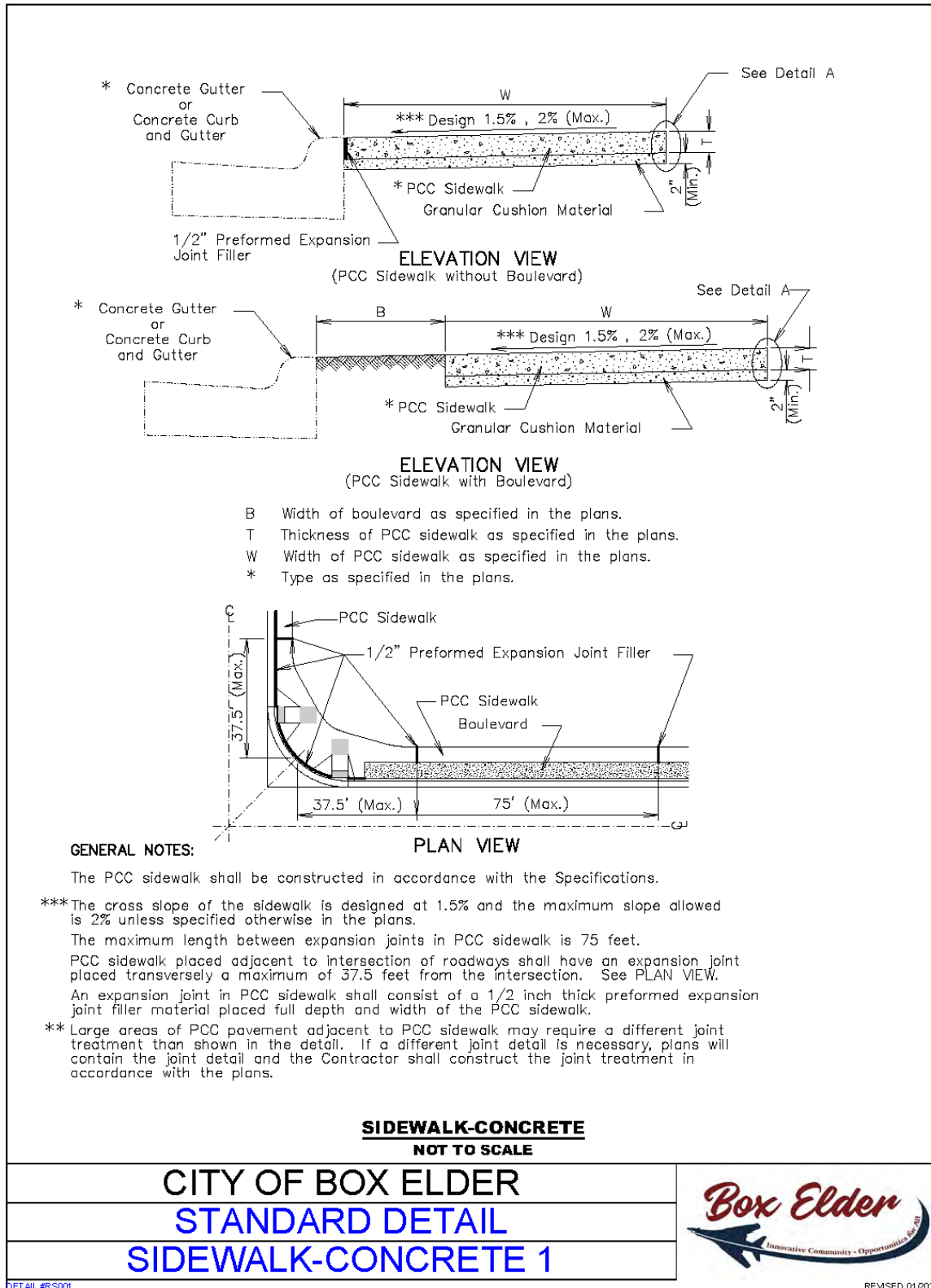

**DETAIL RS002-SIDEWALK-CONCRETE-2**

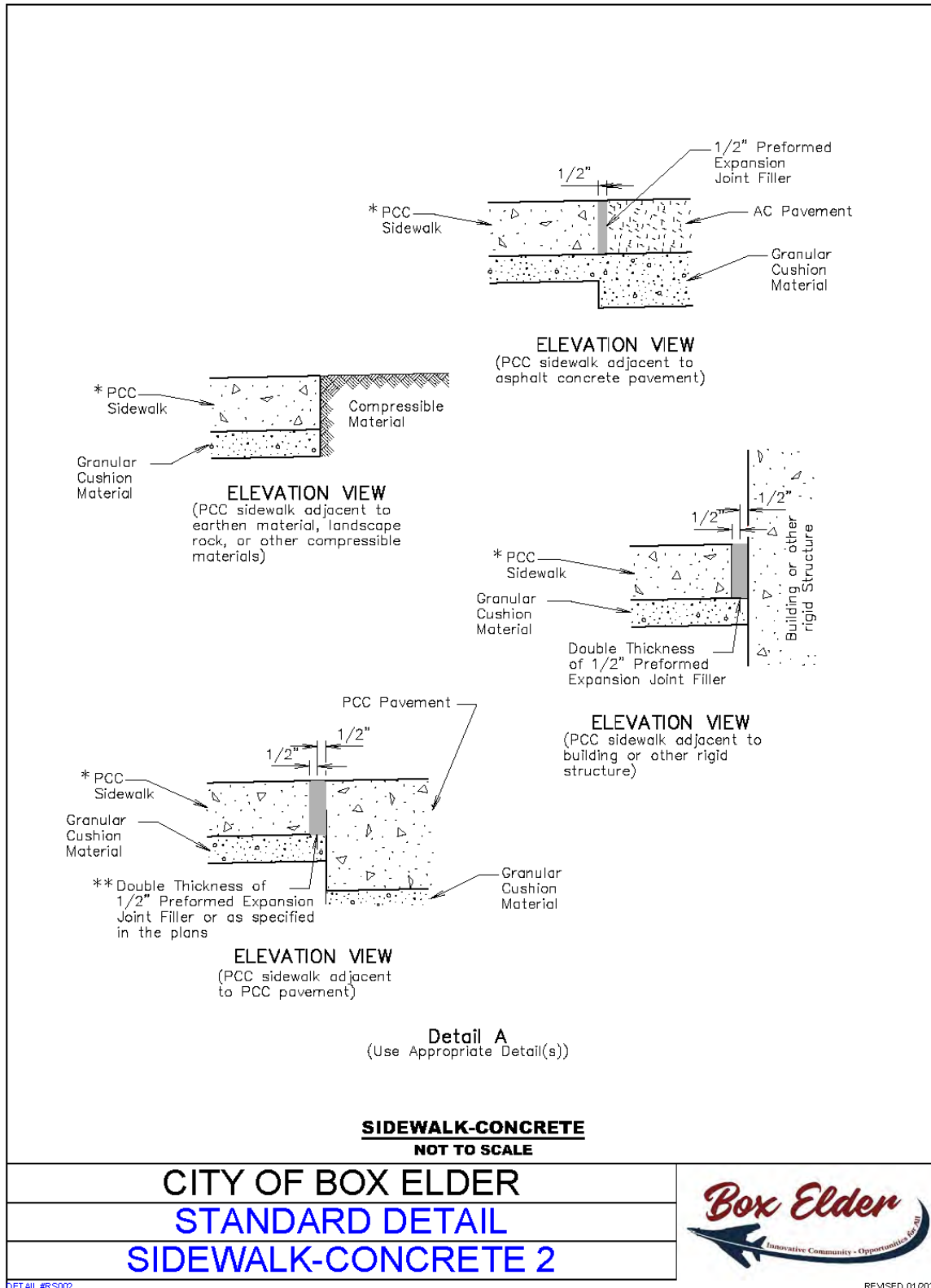

# DETAIL RS010-SIDEWALK-DRAIN

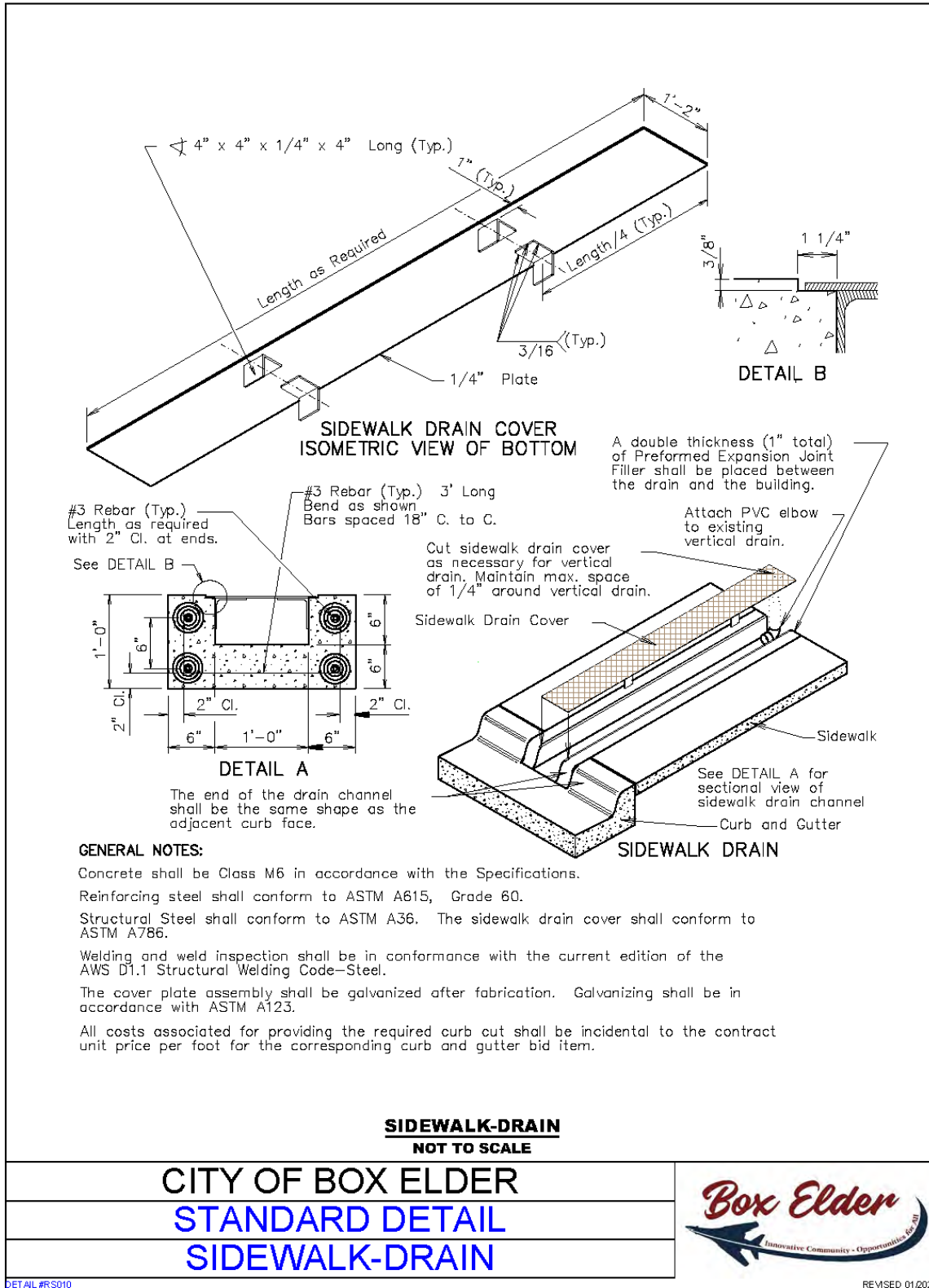

**DETAIL RS011-SIDEWALK-ADJACENT TO TYPE S DROP INLET LID-1**

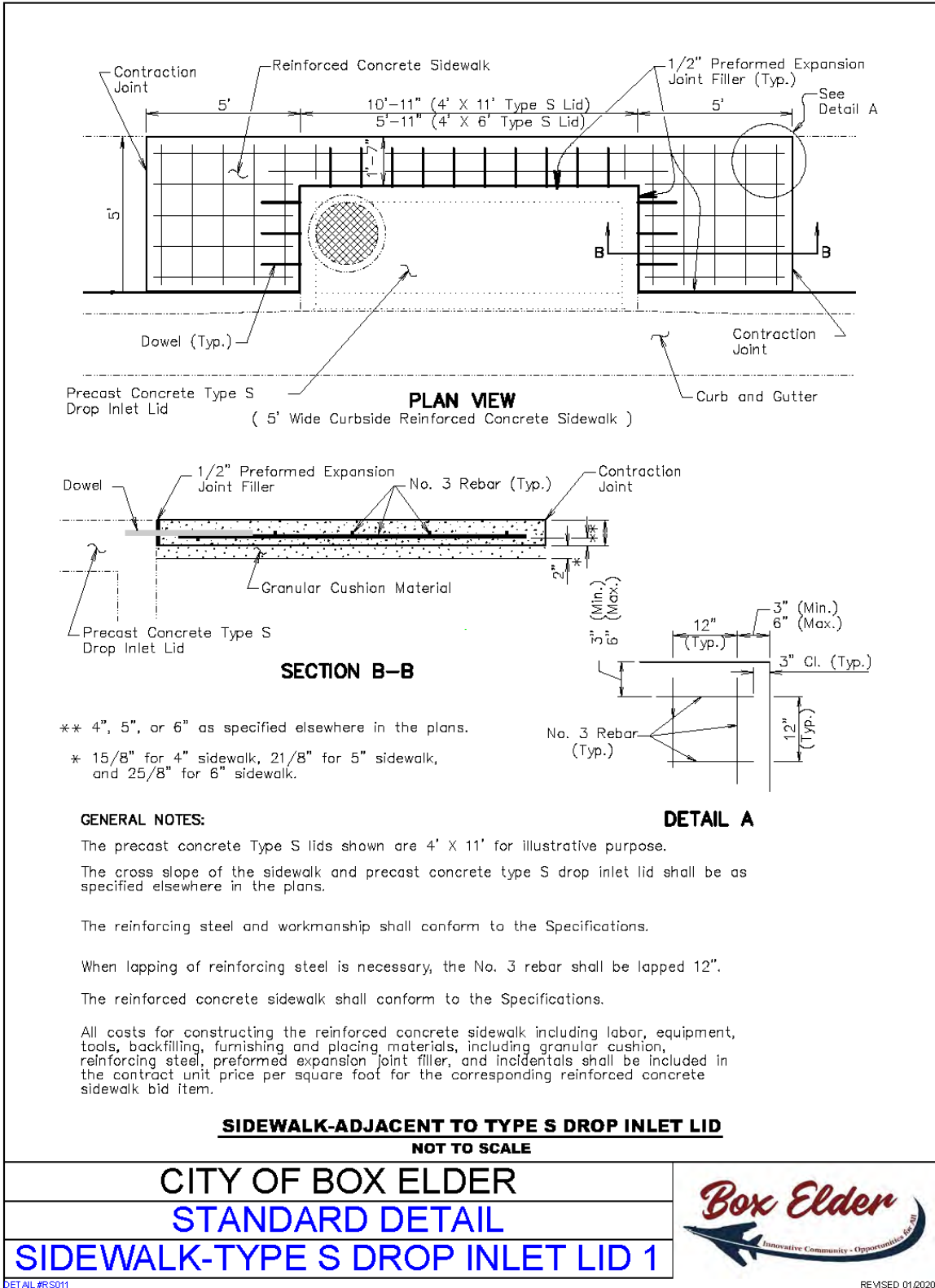



**DETAIL RS012-SIDEWALK-ADJACENT TO TYPE S DROP INLET LID-2**

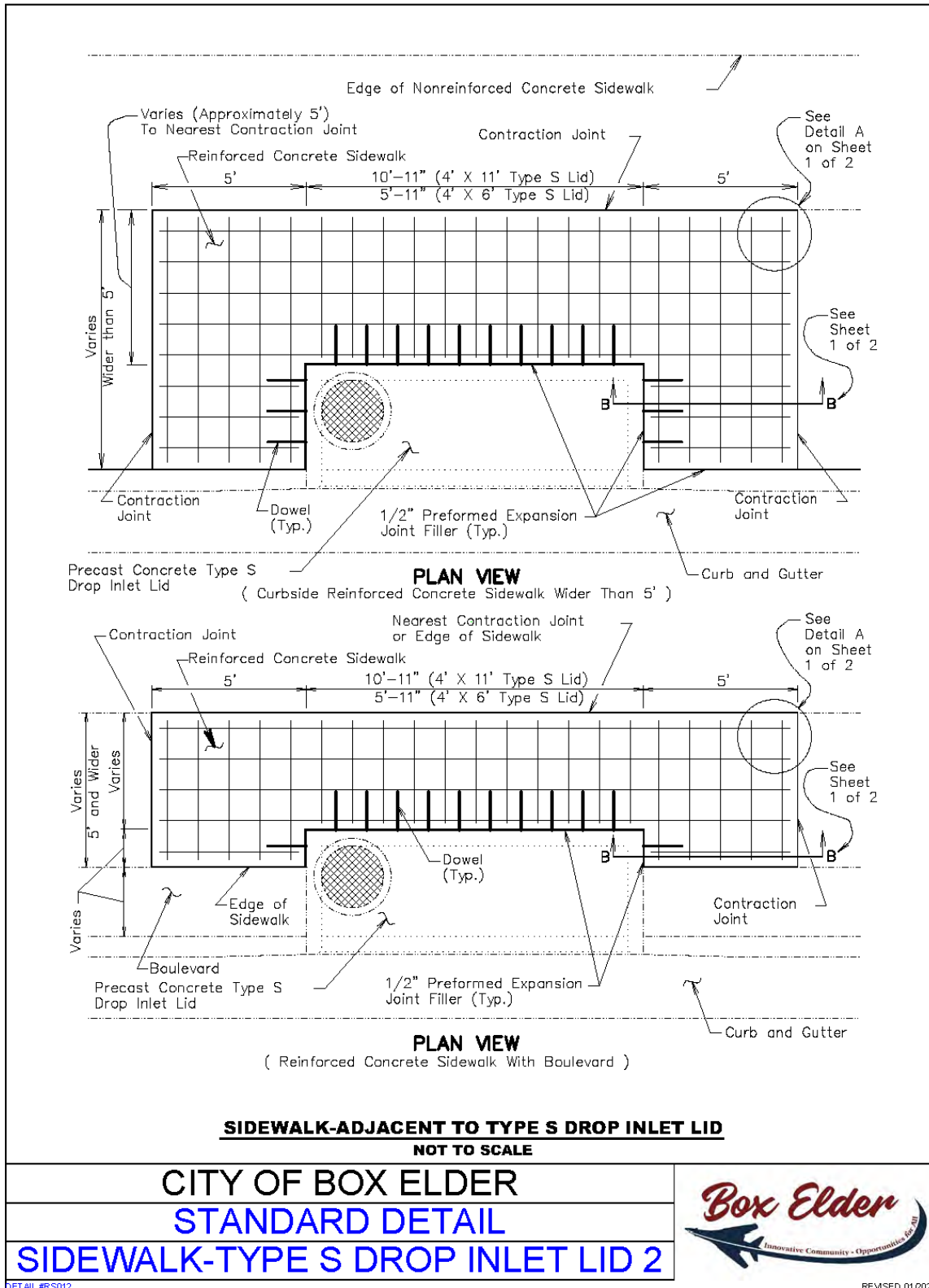

## DETAIL RW001-CONCRETE RETAINING WALL-TYPE C-1

**ELEVATION VIEW  
EXPANSION JOINT FOR FOOTING**

**ELEVATION VIEW  
CONTRACTION JOINT FOR FOOTING**

**DETAIL A  
PLAN VIEW  
EXPANSION JOINT FOR WALL**

**PLAN VIEW  
CONTRACTION JOINT FOR WALL**

**GENERAL NOTES:**

The Type C Concrete Retaining Wall shall be placed adjacent to pavement or curb and gutter as shown in Section D-D on sheet 2 of 2.

\* The sidewalk width of the Type C Concrete Retaining Wall shall not be wider than 8 feet or narrower than 5 feet.

In the areas where the retaining wall footing is to be placed, a 2 inch thickness of cushion material shall be placed and compacted.

All concrete shall be Class M6 and conform to Section 462 of the Specifications.

All reinforcing steel shall be epoxy coated and shall conform to ASTM A615, Grade 60. The smooth bar may conform to ASTM A615, Grade 40. The epoxy coating shall conform to ASTM A775.

For variable height walls, the top b1 bar shall be placed parallel to the top of the wall. The b1 bars shall be lapped a minimum of 12 inches.

A 3/4 inch chamfer shall be provided on all exposed retaining wall edges.

Use Detail B on sheet 2 of 2 for constructing corners in the retaining wall.

The maximum expansion joint spacing shall be 90 feet and the maximum contraction joint spacing shall be 30 feet. The contraction and expansion joints shall be placed to match pavement or curb joints where possible.

The exposed retaining wall surfaces shall receive a finish in accordance with 460.3 L of the Specifications. The exposed surface of the retaining wall footing, when used as a sidewalk, shall receive a broom finish.

The Type C Concrete Retaining Wall shall be measured to the nearest square foot of front face area of the wall. The front face of the footing is excluded from the measurement.

All costs for excavation, furnishing and placing backfill and cushion material, labor, equipment, preformed expansion joint filler, all reinforcing steel including the smooth bars, and all concrete except in the areas of PCC driveway and approach pavement, shall be incidental to the contract unit price per square foot for "Type C Concrete Retaining Wall".

The concrete used for the retaining wall footing that extends into the approach and/or driveway pavement shall be paid for at the contract unit price per square yard for the corresponding "PCC Approach Pavement" and/or "PCC Driveway Pavement" bid items.

**CONCRETE RETAINING WALL-TYPE C  
NOT TO SCALE**

<b>CITY OF BOX ELDER</b>	
<b>STANDARD DETAIL</b>	
<b>RETAINING WALL-CONC.-TYPE C 1</b>	

DETAIL #RW001 REVISED 01/2020

## DETAIL RW002-CONCRETE RETAINING WALL-TYPE C-2

Use No. 4 bars for all reinforcing steel unless specified otherwise.

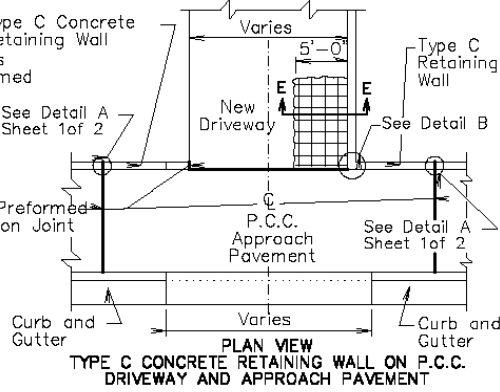
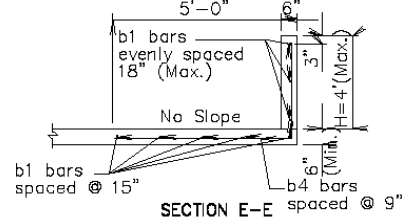
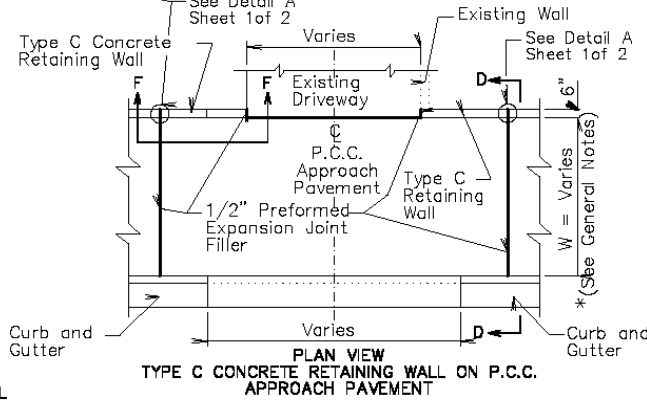
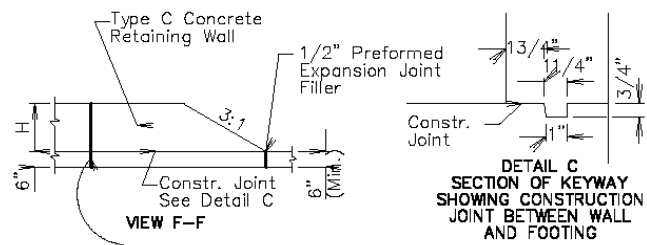
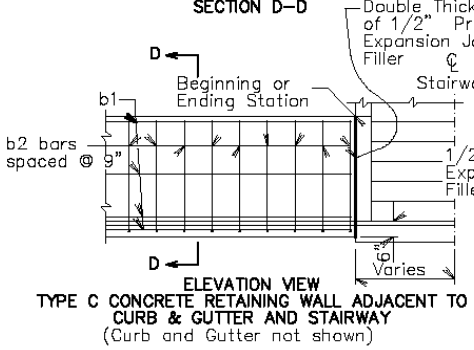
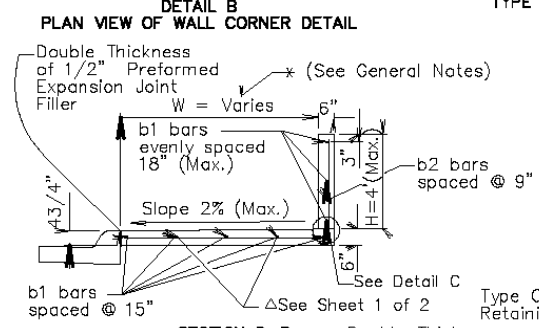
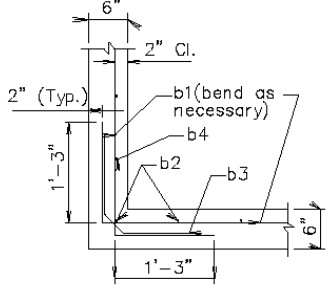
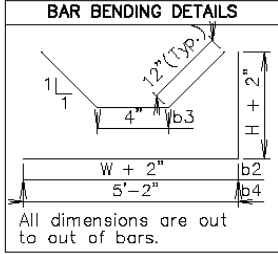

**CONCRETE RETAINING WALL-TYPE C  
NOT TO SCALE**

**CITY OF BOX ELDER  
STANDARD DETAIL  
RETAINING WALL-CONC.-TYPE C 2**



DETAIL RW002

REVISED 01/2020